



msx 110



msx 150



Four Stroke Personal Watercraft Service Manual



POLARIS
The Way Out.

Table of Contents

General Information Model Information / Safety Warnings / General Information	1
Maintenance Periodic Maintenance Tables / Maintenance Procedures	2
Engine Removal and Installation Specifications / Removal and Installation	3
Engine Disassembly, Inspection and Re-Assembly Specifications / Components / Testing / Troubleshooting / Teardown	4
Fuel / Ignition / Exhaust Systems Specifications / Components / Testing / Troubleshooting	5
Propulsion System Specifications / Components / Teardown and Rebuilding / Inspection	6
Hull and Body Systems Specifications / Components / Teardown and Rebuilding / Inspection	7
Electrical System Specifications / NGI Gauge / System Interface Box / Starter Motor / Components	8



POLARIS[®]

WATERCRAFT

MSX 110 / 150 Service Manual

General Information

PWC Identification Numbers	1.1
2004 PWC Publication Part Numbers	1.2
Service Guidelines / Safety Warnings	1.3
MSX 110 General Information	1.4 - 1.5
MSX 150 General information	1.6 - 1.7
Standard Torque Specifications	1.8
Decimal Equivalent Chart	1.9
Conversion Chart	1.10
Tap Drill Sizes	1.11
Service Tools	1.12 - 1.13

GENERAL INFORMATION

2004 PWC Identification Numbers

The engine I.D. number and hull I.D. number are used to register the watercraft. They are unique numbers that distinguish each watercraft from others of the same model.

If the watercraft is ever stolen these numbers will help identify it. The owner should keep a record of these numbers in a place other than the watercraft.

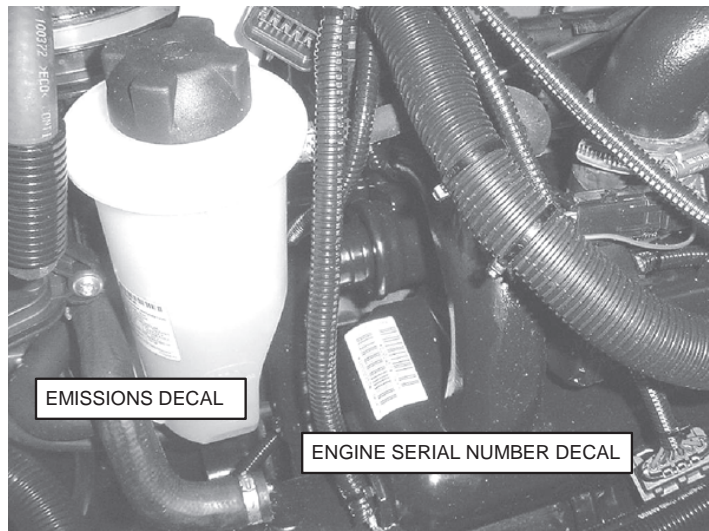
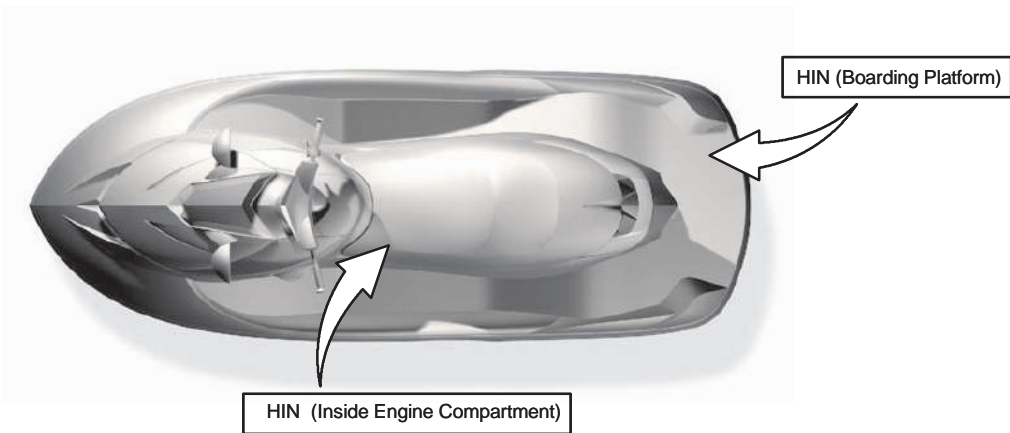
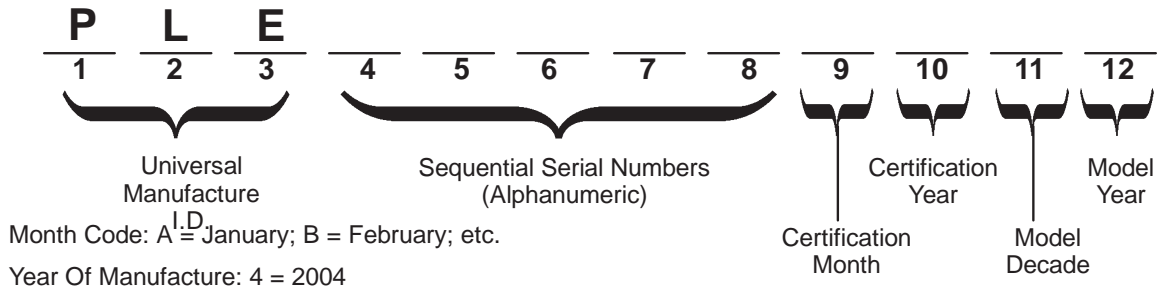

GENERAL INFORMATION

2004 PWC Publication Part Numbers

Model	Model Number	Owner's Manual	Parts Book	Microfiche	Assembly Instructions
MSX 110 (A)	W045304CA	9918972	9919055	9919056	9919173
MSX 110 (A) International	W045304IA				
MSX 110 (B)	W045304CB				
MSX 110 (B) International	W045304IB				
MSX 110 (C)	W045304CC				
MSX 110 (C) International	W045304IC				
MSX 150 (A)	W045305CA		9919057	9919058	
MSX 150 (A) International	W045305IA				
MSX 150 (B)	W045305CB				
MSX 150 (B) International	W045305IB				
MSX 150 (C)	W045305CC				
MSX 150 International	W045305IC				
MSX 150 (D)	W045305CD				
MSX 150 (D) International	W045305ID				

- C = 50 State Domestic (CARB Exemption).
- A / B / C / D = Color Option.
- I = International Model

2004 PWC Service Manual Part Numbers

Book	Part Number
2004 Carbureted / DI™ Models (All)	9919061
2004 Four Stroke PWC Models (All)	9919062
2004 OCTANE Update Packet	9919065
2004 PWC Flat Rate Manual	9919063
2004 Wallchart Packet	TBA

GENERAL INFORMATION

Service Guidelines - Safety Warnings

- Clean inside and outside of watercraft prior to servicing. Clean all parts before installing. Always use a service apron to prevent damage to footwell and top-deck fiberglass.
- Watch for sharp edges which can cause personal injury. Protect hands and arms when working with sharp components.
- Always use a soft-faced hammer and extreme care when removing difficult or stuck components.
- Some fasteners are installed with locking agents or lubricants. Use of impact drivers will aid in fastener removal.
- Always follow torques specifications located throughout manual. Fasteners secured with either too little or too much torque may fail and cause severe property damage, injury or death.
- Always follow torque sequence patterns when found in this manual. Tighten each fastener evenly and to the specified torque value, and with specified locking agent.
- Always use new gaskets, o-rings and seals, clips, cir-clips, and snap rings when assembling components.
- Never re-use Nylok™ or Flex Lock™ nuts when assembling components.
- Never re-use Oetiker™ clamps when removed from fuel lines. Replace with small gear clamps.
- Always use Polaris-authorized lubricants, greases, and locking agents when assembling components. Failure to do so may cause severe engine or vehicle damage.
- Always disconnect the black (-) negative cable first from the battery when removing the battery. When installing the battery, attach the red (+) positive cable first, then the black (-) negative cable.
- Wear appropriate clothing, eye protection, and rubber gloves when working with batteries. Battery acid contains sulfuric acid and is extremely poisonous. Serious burns can result when in contact with skin, clothing, eyes or internal body components.
- If battery acid is ingested, drink large quantities of water or milk. Follow with milk of magnesia, beaten egg or vegetable oil. Call a physician immediately.
- Flush eyes for 15 minutes with water and seek prompt medical attention if acid comes in contact with eyes. Thoroughly wash affected external body parts that come in contact with battery acid with water.
- Keep hands, arms, legs, feet and hair away from rotating parts, hot engine and exhaust components, drive pump and impeller and engine induction when engine is running.
- Never attempt engine or driveline inspections and/or repairs without first removing lanyard and battery cables.
- Gasoline is highly flammable and explosive under certain conditions. Always exercise extreme care when handling gasoline. Do not smoke or allow open flames in or near the area where refueling is performed or where gasoline is stored.
- Always refuel the watercraft outdoors and in a well-ventilated area. Do not fill the tank to the fuel cap.
- If you get gasoline or oil on your skin or clothing, wash it off immediately with soap and water and change clothing.
- The engine exhaust from this product contains chemicals known to cause cancer, birth defects or other reproductive harm. Only run engine outdoors or in a well-ventilated area.
- Never run the engine for more than 15 seconds without cooling water supply.

GENERAL INFORMATION

2004 MSX 110

W045304CA / CB / CC (W045304IA / IB / IC)

Length: 126 in. (320 cm)
 Width: 48.3 in. (122.6 cm)
 Height: 42.5 in. (108 cm)
 Dry Weight: 650lbs. (295 kg)
 Category: Midsize
 Riders: 1 to 3
 Fuel Capacity: 17.8 US Gal. (67.4L)
 Emission Certification: Two Star - Very Low Emission



MSX 110 W045304CB Sarasota Yellow

2004 MSX 110 Emission Certification

The engines in all 2004 MSX 110 Personal Watercraft are certified as Two Star, Very Low Emission engines.

The Two Star label identifies engines that meet the California Air Resources Board (CARB) 2004 exhaust emission standards. Engines meeting these standards have 20% lower emissions than One-Star - Low Emission engines. These engines are equivalent to the U.S. EPA's 2006 standards for marine engines.

Emission Control Information Decals

The emission control information decal is located on the flywheel cover.

2004 MSX 110 Emission Decal

ENGINE FAMILY	3WEBMO.75H01
FAMILY EMISSION LIMIT	36.0 g/kW-hr
EMISSION CONTROL SYSTEM	SFI (Sequential Fuel Injection)
FUEL	Unleaded Gasoline 91 Octane R+M/2
SPARK PLUG	Champion RC7PYCB
SPARK PLUG GAP	.7 - .8mm (.028 - .032 in.)
ADVERTISED HORSEPOWER	82 kW (110HP)
ENGINE DISPLACEMENT	750cc

GENERAL INFORMATION

2004 MSX 110	
Model Number	W045304CA / CB / CC (W045304IA / IB / IC)
Engine	
Platform	Polaris Liberty™ Marine Intercooled Turbocharged Four Stroke
Engine Model Number	ES075WLE-011
Engine Displacement	750cc
Number of Cylinders	2
Cylinder Lining Material	Nicasil
Bore & Stroke (mm)	85 x 66
Compression Ratio (Effective)	9.0:1
Cylinder Compression @ Sea Level	140 ± 14.5 psi (9.6 ± 1 bar) - Both spark plugs removed, engine turnover @ 300 RPM.
Cooling System	Closed loop with engine coolant-to-freshwater heat exchanger.
Thermostat Opening Temperature	82°C
Overheat Warning	Engine Overheat / Exhaust Manifold Overheat Switch - RPM Limit / NGI Warning
Induction Type	Intercooled Turbocharger
Lubrication	Dry Sump
Oil Requirements	Polaris Synthetic PWC Four Stroke Engine Oil (15W-50)
RPM Limiter	7800 to 8400 RPM - Determined by ECU
Exhaust System	Exhaust pipe w/water jacket and water injector.
Sound Reduction	Turbo PLANET™
Engine Management System	
Fuel Delivery	Bosch Multi-Point Fuel Injection
Recommended Fuel	Premium Unleaded Fuel (91 / 92 / 93 Octane)
Idle Speed (In Water)	1550 ± 50 RPM
Ignition System	EMS Bosch ME 7.4.4
Timing Degrees BTDC	22 Degrees BTDC
Spark Plug	Champion RC7PYCB
Spark Plug Gap	.6 - .7mm (.025 - .030 in.)
Electrical	
Magneto Generator Output	25A / 350W @ 3000 RPM
Battery	12 Volts / 19A
Fuses	2A - NGI Gauge / 15A - Battery / 15A - Ignition System / 15A - Fuel Pump 30A - Alternator / 15A x 3 - Main Relay
Starting	Electric Motor - One Button Start / One Button Stop
Propulsion	
Jet Pump Type	Dominator 2 Single Stage Axial Flow w/Six Vane Stainless Steel Stator
Impeller Rotation	Counter Clockwise (From Aft)
Coupling Type	Three piece coupler
Minimum Depth For Operation	2 ft. (60cm.)
Impeller Type	TBA
Impeller Diameter	5.8 in. (148mm)
Reverse System	Manual w/3400 RPM Limit
Hull / Body	
Hull Design	Modified Full V
Hull Material	FRC (Fiberglass Reinforced Composite)
Top Deck Material	FRC (Fiberglass Reinforced Composite)

GENERAL INFORMATION

2004 MSX 150

W045305CA / CB / CC / CD (W045305IA / IB / IC / ID)

Length: 126 in. (320 cm)

Width: 48.3 in. (122.6 cm)

Height: 42.5 in. (108 cm)

Dry Weight: 660 lbs. (301 kg)

Category: Midsize

Riders: 1 to 3

Fuel Capacity: 17.8 US Gal. (67.4L)

Emission Certification: Two Star - Very Low Emission



MSX 150 W045305CD *Stealth Black*

2004 MSX 150 Emission Certification

The engines in all 2004 MSX 150 Personal Watercraft are certified as Two Star, Very Low Emission engines.

The Two Star label identifies engines that meet the California Air Resources Board (CARB) 2004 exhaust emission standards. Engines meeting these standards have 20% lower emissions than One-Star - Low Emission engines. These engines are equivalent to the U.S. EPA's 2006 standards for marine engines.

Emission Control Information Decals

The emission control information decal is located on the flywheel cover.

2004 MSX 150 Emission Decal

ENGINE FAMILY	3WEBMO.75H01
FAMILY EMISSION LIMIT	36.0 g/kW-hr
EMISSION CONTROL SYSTEM	SFI (Sequential Fuel Injection)
FUEL	Unleaded Gasoline 91 Octane R+M/2
SPARK PLUG	Champion RC7PYCB
SPARK PLUG GAP	.7 - .8mm (.028 - .032 in.)
ADVERTISED HORSEPOWER	112 kW (150HP)
ENGINE DISPLACEMENT	750cc

GENERAL INFORMATION

2004 MSX 150	
Model Number	W045305CA / CB / CC / CD (W045305IA / IB / IC / ID)
Engine	
Platform	Polaris Liberty™ Marine Intercooled Turbocharged Four Stroke
Engine Model Number	ES075WLE-011
Engine Displacement	750cc
Number of Cylinders	2
Cylinder Lining Material	Nicasil
Bore & Stroke (mm)	85 x 66
Compression Ratio (Effective)	9.0:1
Cylinder Compression	140 ± 14.5 psi (9.6 ± 1 bar) - Both spark plugs removed, engine turnover @ 300 RPM.
Cooling System	Closed loop with engine coolant-to-freshwater heat exchanger.
Thermostat Opening Temperature	82°C
Overheat Warning	Engine Overheat / Exhaust Manifold Overheat Switch - RPM Limit / NGI Warning
Induction Type	Intercooled Turbocharger
Lubrication	Dry Sump
Oil Requirements	Polaris Synthetic PWC Four Stroke Engine Oil (15W-50)
RPM Limiter	7800 to 8400 RPM - Determined by ECU.
Exhaust System	Exhaust pipe w/water jacket and water injector.
Sound Reduction	Turbo PLANET™
Engine Management System	
Fuel Delivery	Bosch Multi-Point Fuel Injection
Recommended Fuel	Premium Unleaded Fuel (91 / 92 / 93 Octane)
Idle Speed (In Water)	1550 ± 50 RPM
Ignition System	EMS Bosch ME 7.4.4
Timing Degrees BTDC	22 Degrees BTDC
Spark Plug	Champion RC7PYCB
Spark Plug Gap	.6 - .7mm (.025 - .030 in.)
Electrical	
Magneto Generator Output	25A / 350W @ 3000 RPM
Battery	12 Volts / 19A
Fuses	2A - NGI Gauge / 15A - Battery / 15A - Ignition System / 15A - Fuel Pump 30A - Alternator / 15A x 3 - Main Relay
Starting	Electric Motor - One Button Start / One Button Stop
Propulsion	
Jet Pump Type	Dominator 2 Single Stage Axial Flow w/Six Vane Stainless Steel Stator
Impeller Rotation	Counter Clockwise (From Aft)
Coupling Type	Three piece coupler
Minimum Depth For Operation	2 ft. (60cm.)
Impeller Type	12 - 18 3 Blade
Impeller Diameter	5.8 in. (148mm)
Reverse System	Manual w/3400 RPM Limit
Hull / Body	
Hull Design	Modified Full V
Hull Material	FRC (Fiberglass Reinforced Composite)
Top Deck Material	FRC (Fiberglass Reinforced Composite)

GENERAL INFORMATION

Standard Torque Specifications

The following torque specifications are to be used as a general guideline. Use standard torque values for the appropriate size fastener when torque values are not specified. **Always consult the specific manual section for torque values of fasteners and use of locking agent. When fastener replacement is required, use only genuine Polaris fasteners.**

RECOMMENDED TORQUE SPECIFICATION STAINLESS STEEL FASTENERS (SAE)		
Bolt Size	Threads/Inch	Torque
8	18 & 32	28 in. lbs.
10	24 & 32	40 in. lbs.
1/4	20 & 28	8 ft. lbs.
5/16	18 & 24	14 ft. lbs.
3/8	16	25 ft. lbs.
3/8	24	28 ft. lbs.
7/16	14	40 ft. lbs.
1/2	13	58 ft. lbs.
1/2	20	70 ft. lbs.

RECOMMENDED TORQUE SPECIFICATION STAINLESS STEEL FASTENERS (METRIC)	
Bolt Size	Torque
5mm	45-52 in. lbs.
6mm	66-78 in. lbs.
8mm	13-16 ft. lbs.
10mm	26-30 ft. lbs.
12mm	40-44 ft. lbs.

GENERAL INFORMATION

Decimal Equivalent Chart

1/640156	
	1/320312
			1 mm = .0394"
3/640469	
	1/160625
5/640781	2 mm = .0787"
	3/320938
7/641094	3 mm = .1181"
	1/81250
9/641406	
	5/321563
			4 mm = .1575"
11/641719	
	3/161875
			5 mm = .1969"
13/642031	
	7/322188
15/642344	6 mm = .2362"
	1/425
17/642656	7 mm = .2756"
	9/322813
19/642969	
	5/163125
			8 mm = .3150"
21/643281	
	11/323438
			9 mm = .3543"
23/643594	
	3/8375
25/643906	10 mm = .3937"
	13/324063
27/644219	11 mm = .4331"
	7/164375
29/644531	
	15/324688
			12 mm = .4724"
31/644844	
	1/25
			13 mm = .5118
33/645156	
	17/325313
35/645469	14 mm = .5512"
	9/165625
37/645781	15 mm = .5906"
	19/325938
39/646094	
	5/8625
			16 mm = .6299"
41/646406	
	21/326563
			17 mm = .6693"
43/646719	
	11/166875
45/647031	18 mm = .7087"
	23/327188
47/647344	19 mm = .7480"
	3/475
49/647656	
	25/327813
			20 mm = .7874"
51/647969	
	13/168125
			21 mm = .8268"
53/648281	
	27/328438
55/648594	22 mm = .8661"
	7/8875
57/648906	23 mm = .9055"
	29/329063
59/649219	
	15/169375
			24 mm = .9449"
61/649531	
	31/329688
			25 mm = .9843
63/649844	
	1	1.0

GENERAL INFORMATION

Conversion Chart

Unit of Measure	Multiplied by	Converts to
ft. lbs.	x 12	= in. lbs.
in. lbs.	x .0833	= ft. lbs.
ft. lbs.	x 1.356	= Nm
in. lbs.	x .0115	= kg-m
Nm	x .7376	= ft. lbs.
kg-m	x 7.233	= ft. lbs.
kg-m	x 86.796	= in. lbs.
kg-m	x 10	= Nm
in.	x 25.4	=mm
mm	x .03937	= in.
in.	x 2.54	= cm
mile (mi.)	x 1.6	= km
km	x .6214	= mile (mi.)
Ounces (oz.)	x 28.35	= Grams (g)
Grams (g)	x 0.035	= Ounces (oz.)
lb.	x .454	= kg
kg	x 2.2046	= lb.
Cubic inches (cu in)	x 16.387	= Cubic centimeters (cc)
Cubic centimeters (cc)	x 0.061	= Cubic inches (cu in)
Imperial pints (Imp pt)	x 0.568	= Liters (l)
Liters (l)	x 1.76	= Imperial pints (Imp pt)
Imperial quarts (Imp qt.)	x 1.137	= Liters (l)
Liters (l)	x 0.88	= Imperial quarts (Imp qt.)
Imperial quarts (Imp qt.)	x 1.201	= US quarts (US qt.)
US quarts (US qt.)	x 0.833	= Imperial quarts (Imp qt.)
US quarts (US qt.)	x 0.946	= Liters (l)
Liters (l)	x 1.057	= US quarts (US qt.)
US gallons (US gal)	x 3.785	=Liters (l)
Liters (l)	x 0.264	= US gallons (US gal)
Pounds - force per square inch (psi)	x 6.895	= Kilopascals (kPa)
Kilopascals (kPa)	x 0.145	= Pounds - force per square inch (psi)
Kilopascals (kPa)	x 0.01	= Kilograms - force per square cm
Kilograms - force per square cm	x 98.1	= Kilopascals (kPa)

°C to °F: $9 (°C + 40) \div 5 - 40 = °F$

°F to °C: $5 (°F + 40) \div 9 - 40 = °C$

GENERAL INFORMATION

SAE Tap Drill Sizes

Thread Size	Drill Size	Thread Size	Drill Size
#0-80	3/64	1/2-13	27/64
#1-64	53	1/2-20	29/64
#1-72	53	9/16-12	31/64
#2-56	51	9/16-18	33/64
#2-64	50	5/8-11	17/32
#3-48	5/64	5/8-18	37/64
#3-56	45	3/4-10	21/32
#4-40	43	3/4-16	11/16
#4-48	42	7/8-9	49/64
#5-40	38	7/8-14	13/16
#5-44	37	1-8	7/8
#6-32	36	1-12	59/64
#6-40	33	1 1/8-7	63/64
#8-32	29	1 1/8-12	1 3/64
#8-36	29	1 1/4-7	1 7/64
#10-24	24	1 1/4-12	1 11/64
#10-32	21	1 1/2-6	1 11/32
#12-24	17	1 1/2-12	1 27/64
#12-28	4.6mm	1 3/4-5	1 9/16
1/4-20	7	1 3/4-12	1 43/64
1/4-28	3	2-4 1/2	1 25/32
5/16-18	F	2-12	1 59/64
5/16-24	I	2 1/4-4 1/2	2 1/32
3/8-16	O	2 1/2-4	2 1/4
3/8-24	Q	2 3/4-4	2 1/2
7/16-14	U	3-4	2 3/4
7/16-20	25/64		

Metric Tap Drill Sizes

Tap Size	Drill Size	Decimal Equivalent	Nearest Fraction
3 x .50	#39	0.0995	3/32
3 x .60	3/32	0.0937	3/32
4 x .70	#30	0.1285	1/8
4 x .75	1/8	0.125	1/8
5 x .80	#19	0.166	11/64
5 x .90	#20	0.161	5/32
6 x 1.00	#9	0.196	13/64
7 x 1.00	16/64	0.234	15/64
8 x 1.00	J	0.277	9/32
8 x 1.25	17/64	0.265	17/64
9 x 1.00	5/16	0.3125	5/16
9 x 1.25	5/16	0.3125	5/16
10 x 1.25	11/32	0.3437	11/32
10 x 1.50	R	0.339	11/32
11 x 1.50	3/8	0.375	3/8
12 x 1.50	13/32	0.406	13/32
12 x 1.75	13/32	0.406	13/32

GENERAL INFORMATION

Service Tools

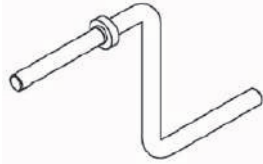

PW-46981 - REQUIRED TOOL
CRANKSHAFT HAND CRANK (BARRING TOOL)
 USED TO ROTATE CRANKSHAFT

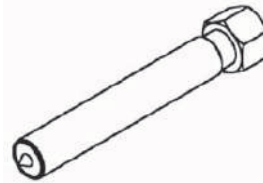

PW-46989 - REQUIRED TOOL
MAGNET ROTOR / GEAR REMOVER BOLT
 USED TO REMOVE MAGNET ROTOR AND BALANCE SHAFT GEAR WHEN USED WITH PW-46982.

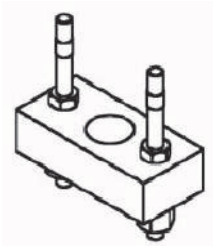

PW-46982 - REQUIRED TOOL
GEAR REMOVAL TOOL
 USED TO REMOVE BALANCE SHAFT GEAR WHEN USED WITH PW-46989 GEAR REMOVER BOLT.

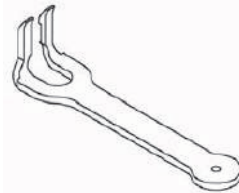

PW-46991 - REQUIRED TOOL
VALVE COMPRESSOR TOOL
 USED TO COMPRESS VALVE SPRINGS WITH ENGINE EITHER INSTALLED OR REMOVED FROM WATERCRAFT HULL.

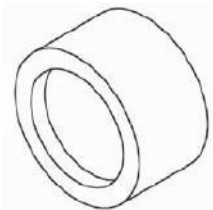

PW-46983 - REQUIRED TOOL
PISTON RING COMPRESSOR
 USED TO INSTALL PISTONS INTO ENGINE BLOCK

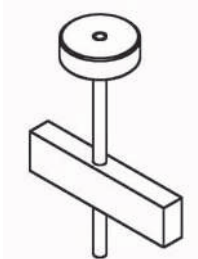

PW-47077 - REQUIRED TOOL
CAMSHAFT ALIGNMENT TOOL
 INSTALLS INTO CAMSHAFT TO LOCK INTO BDC POSITION.

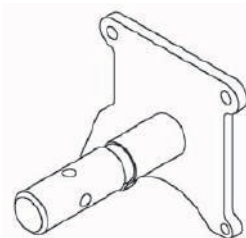

PW-46984 - REQUIRED TOOL
ENGINE STAND ADAPTER PLATE
PW-47054
ENGINE STAND ADAPTER SLEEVE
 ATTACHES TO REAR OF ENGINE BLOCK. ALLOWS TECHNICIAN TO ROTATE ENGINE DURING DISASSEMBLY AND RE-ASSEMBLY.

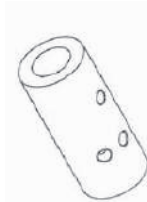

ADAPTER SLEEVE EXPANDS MOUNTING OPTIONS WHEN USING DIFFERENT ENGINE STANDS.

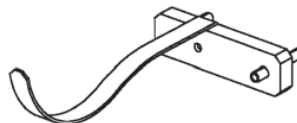

PW-47079 - REQUIRED TOOL
TIMING CHAIN INSTALLATION TOOL
 ROUTES TIMING CHAIN THROUGH ENGINE CRANKCASE DURING INSTALLATION.



PW-47108 - REQUIRED TOOL
TIMING CHAIN WEDGE AND HOOK TOOL
 USED DURING TIMING CHAIN INSTALLATION

GENERAL INFORMATION

Service Tools



PW-47053 - OPTIONAL TOOL
ADAPTER PLATE TABLE MOUNT
USED TO MOUNT ENGINE STAND ADAPTER PLATE TO WORK-BENCH.



PW-46985 - REQUIRED TOOL
TIMING CHAIN LINK REMOVAL / INSTALLATION TOOL
USED IN REMOVING AND RE-INSTALLING TIMING CHAIN.



PW-43070 - OPTIONAL TOOL
ROLLING ENGINE STAND
ACCEPTS PW-46984 ENGINE STAND ADAPTER PLATE



PU-46219 - OPTIONAL TOOL
MANUAL OIL PUMP / CONTAINER
USED TO REMOVE OIL FROM OIL TANK



PU-47102 - REQUIRED TOOL
MSX 110 / 150 COMM. CABLE ADAPTER
CONNECTS LAPTOP CABLE TO ENGINE WIRING HARNESS.



DIGITAL WRENCH DIAGNOSTIC SOFTWARE
REQUIRED TOOLS
COMPLETE KIT: PU-47063
UPDATE SOFTWARE ONLY: PU-47052



POLARIS[®] *WATERCRAFT*

MSX 110 / 150 Service Manual

Maintenance

Periodic Maintenance Table	2.1
Safety Warnings	2.2
Maintenance Tools / Torque Guide	2.3
Flush Kit	2.3
Service Products	2.4
Steering / Reverse System Lubrication	2.5
Steering Post Removal / Assembly	2.6
Steering / Reverse Cable Adjustment	2.7
E.S.P. Function Testing	2.8
Valve Clearance Adjustment Procedure	2.8 - 2.9
Engine Oil Level Check	2.10
Oil Change Procedure	2.10 - 2.11
Engine Coolant Inspection / Change Procedure	2.12
Cooling System Pressure Test	2.13
Engine Compression / Fuel System Pressure Tests	2.14
Battery Safety and Maintenance	2.15 - 2.17
Spark Plug	2.18
Fuses	2.18
Exhaust Cooling Injector Maintenance	2.19
Throttle Cable Adjustment	2.19
Gasoline Safety / Fuel System Maintenance / Fuel Filter	2.20
Bilge System / Siphons	2.21
Propulsion System Maintenance	2.22 - 2.23
Handlebar Maintenance / Intake Manifold Re-Torque Procedure	2.24
Drain Plugs	2.25
Off-Season Storage	2.26

MAINTENANCE

Periodic Maintenance Table

The periodic maintenance table must be followed in order to ensure maximum watercraft performance and long-term durability. Certain procedures require advanced mechanical and/or electrical knowledge. These procedures will be noted within the table.

Operating a Personal Watercraft in saltwater or rough conditions requires additional service and maintenance attention. When checked (✓) the procedure must be completed after watercraft operation.

- ✓ = Requires basic mechanical and/or electrical knowledge.
- = Requires advanced mechanical and/or electrical knowledge.
- R = REPLACE
- * = Every 4 years

ITEM	PROCEDURE	BREAK IN PERIOD (Hours)	REGULAR INTERVAL (Hours)			PRE RIDE	SALT WATER	END OF YEAR
		10 - 12	25	50	100			
Spark Plugs	Adjust Gap / Clean	✓			✓ R			✓
Flame Arrestor	Inspect	✓					✓	
Engine Oil	Inspect Level	✓	✓			✓		✓R
Engine Oil / Filter	Replace	✓R	✓R					✓R
Engine Coolant	Inspect	✓		✓		✓		✓
Engine Coolant	Replace				■*			
Compression	Inspect	■			■			
Valve Clearance	Inspect / Adjust	■			■			
Cooling / Oil / Air Hoses	Inspect	✓		✓		✓	✓	
Engine Mounts	Inspect	■			■			
Engine Fasteners	Inspect	■			■			
Intake Manifold	Adjust Torque	✓	✓					
Chassis Fasteners	Inspect	■			■			
Freshwater Loop	Flush	✓		✓			✓	✓
Exhaust System	Inspect	✓		✓			✓	
Throttle Cable	Inspect / Adjust / Lubricate	✓		✓		✓	✓	
Reverse Cable	Inspect / Adjust / Lubricate	✓		✓		✓	✓	
Steering Cable	Inspect / Adjust / Lubricate	✓		✓		✓		
Handlebars	Inspect / Adjust	✓		✓		✓		
ESP Function	Inspect	✓				✓		
Impeller / Pump	Inspect / Flush	✓		✓			✓	
Sacrificial Anode	Inspect	✓		✓			✓	✓
Drive Couplers	Inspect	✓			✓			
Bilge Area / Drains	Inspect / Clean / Flush	✓			✓	✓	✓	✓
Battery / Vent	Inspect	✓			✓			✓
Electrical Connections	Inspect	✓			✓			
Fuel System	Inspect	■			■			✓
Fuel / Vent Hoses	Inspect	✓			✓			✓
Fuel Tank	Inspect	■						✓
Fuel Filter	Replace				■			
Fire Extinguisher	Inspect	✓				✓		
Start / Stop Switch	Inspect	✓				✓		

MAINTENANCE

Maintenance Notes / Safety Warnings

WARNING

Gasoline is extremely flammable and explosive under certain conditions.

- Always stop the engine and refuel outdoors or in a well ventilated area.
- Do not smoke or allow open flames or sparks in or near the area where refueling is performed or where gasoline is stored.
- Do not overfill the tank. Do not fill the tank neck above the fuel tank insert. Leave air space to allow for fuel expansion.
- If you get gasoline in your eyes or if you swallow gasoline, see your doctor immediately. Never try to syphon gasoline using mouth suction.
- If you spill gasoline on your skin or clothing, immediately wash it off with soap and water and change clothing.
- Never start the engine or let it run in an enclosed area. Engine exhaust fumes are poisonous and can cause loss of consciousness or death in a short time.

WARNING

The engine exhaust from this product contains chemicals known to cause cancer, birth defects or other reproductive harm.

WARNING

Improper repairs or service can create unsafe conditions that may cause severe personal injury or death.

WARNING

The engine and exhaust components on this product become very hot during operation and remain so for a period of time after the engine is stopped.

MAINTENANCE

Maintenance - Specific Tools

TOOL	PART NUMBER
Compression Gauge	PV-33223
Fuel Pressure Gauge	PV-43506
Oil Pressure Gauge	PV-43531
Feeler Gauge	Commercially Available
Spark Plug Gap Gauge / Feeler Gauge	Commercially Available
Fluke 77 Digital Multimeter	PV-43568
Fluke Compatible Peak Voltage Tester	PV-39991
PWC Four Stroke Flush Kit	2874833
Oil Pump and Containment System	PW-46219
Valve Adjustment Tool	PW-46991

Maintenance Procedures Fastener Torque Guide

FASTENER	SPECIFIED TORQUE		
	FOOT POUNDS	NEWTON METERS	SPECIAL
SPARK PLUG	20	27	AS
IGNITION COILS	7	10	
OIL FILTER CAP	17	24	
VALVE COVER	7	10	
ENGINE MOUNT-TO-HULL	14		Loctite™ 262
ENGINE STRAP-TO-ENGINE MOUNT	50		Loctite™ 262
STEERING CABLE JAM NUTS	40 in.lbs.	4.5Nm	
STEERING CABLE ADJUSTER CLAMP	8	11	Loctite™ 242
REVERSE CABLE JAM NUTS	40 in.lbs.	4.5Nm	
STEERING CLAMP	8	11	Loctite™ 242
SACRIFICIAL ANODE	25 in. lbs.	2.8Nm	
PTO DRIVE COUPLER	HAND TIGHTEN		

Flush Kit

A flush kit will allow the operator to clean the freshwater cooling circuit after riding in saltwater or for performing routine maintenance procedures. The addition of a flush kit is highly recommended for performing maintenance procedures such as changing the engine oil.

Polaris PWC Four Stroke Flush Kit PN: 2874833

1. Follow the instructions included within the kit and install the flush kit in the FRESHWATER cooling hose located between the water-to-water heat exchanger and oil storage tank.

NOTE: Only allow the flow of water to the flush kit after the engine has started, and always turn off the flow of water before stopping the engine.

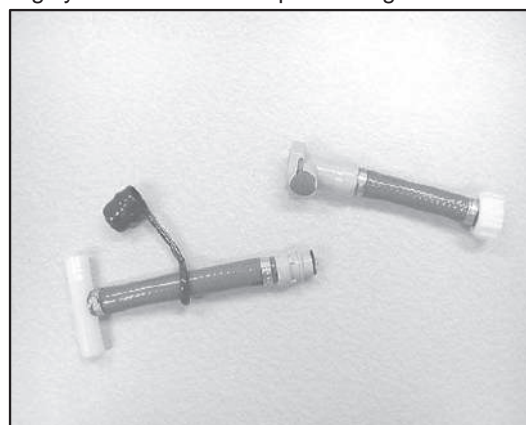

MAINTENANCE

Maintenance - Service Products

Polaris Synthetic Marine PS-4 Engine Oil	2874862 - 12 (1 Quart) Case
	2874863 - 4 (1 Gallon) Case
	2874864 - 55 Gallon Drum
Oil Filter	PN: 0451848
Polaris Environmentally Safe Engine Coolant (100% Propylene Glycol)	2875063 - 1 Gallon Container (100% Propylene Glycol) <i>(Used to boost cold weather protection freeze temperature in cold weather states.)</i>
Polaris Environmentally Safe Engine Coolant (50 / 50 Pre-Mix)	2875041 - 6 (1 Gallon) Case
	2875042 - 55 Gallon Drum
Polaris Premium All Season Grease	2871312 (Grease Gun Kit)
	2871322 (3 oz. / 4 Pack)
	2871423 (14 oz. Tube)
Nyogel Di-Electric Grease	2871329
Champion Spark Plug RC7PYCB	PN: 0451967
Fuel Filter	2520387 (10 Micron Filter)

MAINTENANCE

Steering Cable / Steering Joints

1. Expose inner linkage and apply grease.

**Polaris Premium Grease
PN 2871423**

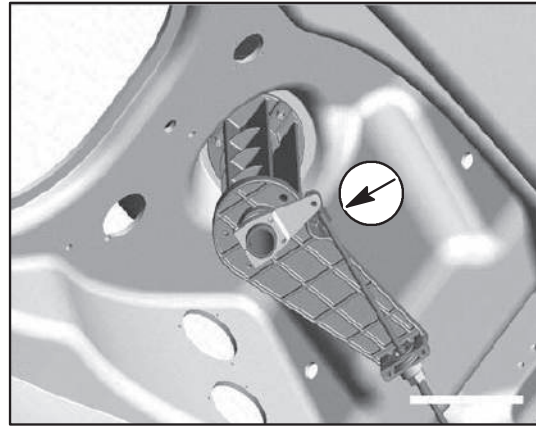

Steering Nozzle

1. Apply light film of grease to exposed steering linkage and pivot points.

**Polaris Premium Grease
PN 2871423**

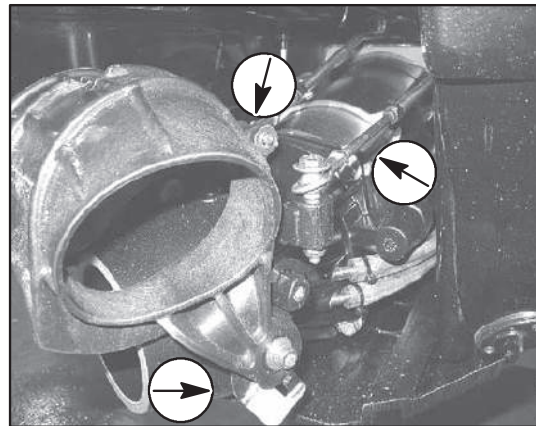

Reverse System

1. Generously lubricate reverse cable.

**Polaris Premium Grease
PN 2871423**

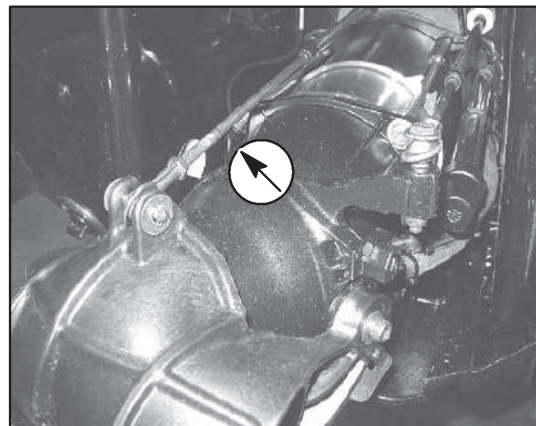

MAINTENANCE

Steering Post Removal

1. Remove handlebar cover fasteners. The grab handle fasteners are located under the cover. If grab handle replacement is required, remove the two fasteners as well.
2. Disconnect the throttle cable from the throttle flipper, and the left-hand control wiring harness.
3. Loosen and remove the steering arm clamp retaining bolt from the bottom of the steering post. Remove the clamp, shim(s) and tapered bushing from the post.
4. Carefully pull the steering post assembly up and out of the steering housing.

NOTE: The steering cable rod-end can remain connected to the steering clamp. If the rod-end is removed, discard the Nylok nut.

Steering Post Assembly

1. Apply lithium-based grease to the inside bore of the upper tapered bushing and steering post.
2. Insert the post assembly into the steering housing.
3. Push down on the handlebars. Verify the strike plate just clears the stop bolt washer and cannot be turned past the stop bolt.
4. If strike plate hits washer, remove post and install shim between bushing and strike plate. Repeat step 3. If plate continues to hit washer, install second and final shim.
5. Apply lithium-based grease to the inside bore of the lower tapered bushing and install into steering housing.
6. The number of shims installed on the lower section of the post is determined by the number installed on top. The total number of shims used to install the entire steering post assembly equals two. (If two shims are installed on top, then zero shims are installed on the bottom, etc.)
7. Align slot on steering arm clamp with cutout in post. Push clamp up against shims while pushing down on the handlebars. Torque bolt to 8 ft.lbs. (11 Nm).
8. Verify handlebars move without resistance from left to right and that handlebars cannot be turned past the steering stop bolt.
9. If steering cable rod-end was removed, reinstall on top of clamp using a new nut. Torque nut to 8 ft.lbs. (11 Nm)
10. Reconnect wiring harness and throttle cable. Verify throttle cable freeplay is set to specifications outlined in chapter two.
11. Reinstall the handlebar grab handle and cover assembly.

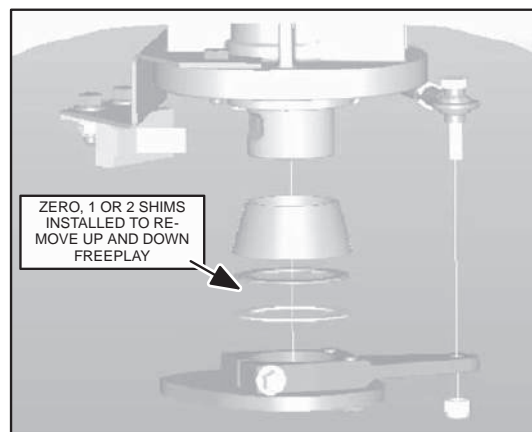
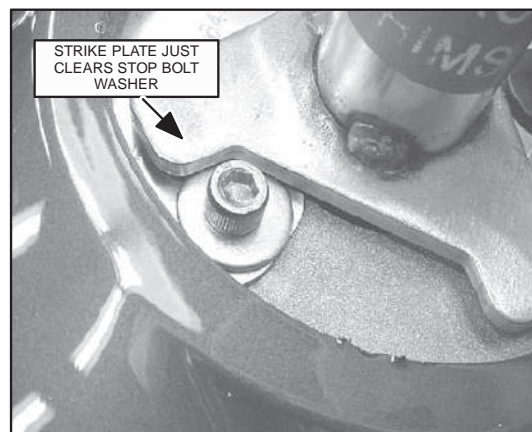
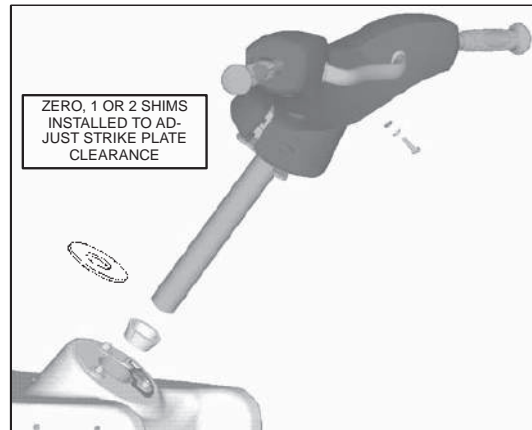

MAINTENANCE

Steering Cable Adjustment

1. Open front compartment door. Loosen and remove adjuster block. Align handlebars with centerline of watercraft. (Straight)
2. Place a straight edge across horizontal center line of steering nozzle or trim nozzle.
3. Measure distance from straight edge to hull on left and right side. Be sure to measure at right angles to the straight edge and at equal distances from the nozzle. The distance at (X) should be equal when handlebars are straight.
4. Adjustments can be made at the adjuster block. Turn block clockwise or counterclockwise until (X) measurements equal.
5. Tighten adjuster block screws to specification.

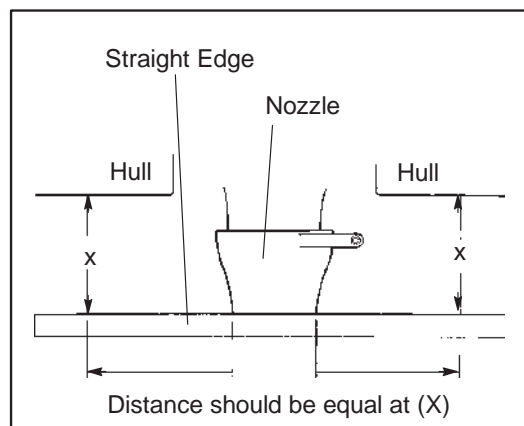

Reverse Cable Adjustment

Under normal operation, the reverse cable should not require adjustment. If the reverse linkage does not function properly, inspect the cable for damage. Inspect all linkage, fasteners, brackets, and pivots for wear or damage. When a new cable is installed the cable must be adjusted.

1. Place reverse shift lever in reverse position.
2. Loosen cable adjuster nuts.
3. Verify that the gate is in its full down position and locked.
4. Check gate locking by pulling up on gate when in down position.
5. Move shift lever to forward position. Reverse gate must be well above the water stream.
6. Tighten adjuster nuts securely.
7. Seal the cable threads and adjuster nuts with marine grade silicone sealant (PN 8560054) and tighten securely. Allow sealant to cure fully before operating craft.

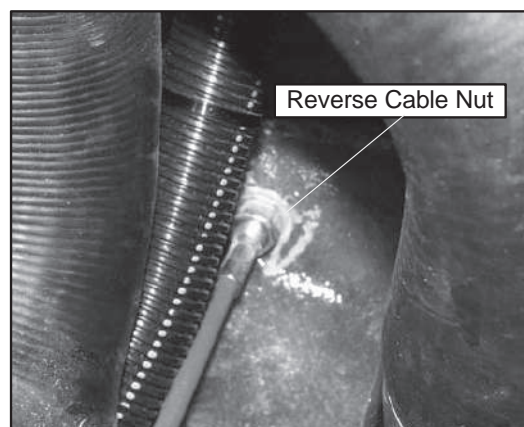

MAINTENANCE

E.S.P. Function Testing

1. Watercraft must be on engine stand or on trailer to perform test.
2. Insert lanyard into stop switch. Start engine.

NOTE: Severe engine damage may occur if engine is run more than 30 seconds without supplying water to the freshwater cooling circuit.

3. Using shop air, spin the paddle wheel located in the rear of the ride plate. Enough air must be directed at the paddle wheel to generate a speed reading on the gauge above 15 MPH.
4. With the indicated vehicle speed above 15 MPH, quickly turn the handlebars either to the full left or full right position.

When the procedure is performed, the engine idle should rise above 1400 - 1500 RPM.

Valve Clearance Adjustment Procedure

NOTE: Always perform procedure when the engine is cold.

Adjusting the valve clearance can be accomplished while the engine is inside the engine compartment.

1. Remove the ignition coils, spark plugs, fuel injector wiring harness, and cam phase sensor harness connector from the valve cover.
2. Remove the valve cover from the engine.
3. Insert the lanyard into the stop switch. Rapidly tap the start button to rotate the engine.
4. Rotate the engine until the MAG cylinder is at TDC - COMPRESSION stroke.

NOTE: TDC - COMPRESSION stroke is found when the both cam lobes are pointed down, away from the rocker arms, and the piston is at TDC.

5. Verify each rocker arm is loose and not engaged by the camshaft.
6. Using a feeler gauge, measure the clearance at each of the 4 valves between the installed shim and rocker arm. Record each measurement. (Photo B)
7. If the measured clearance is within specification, no adjustment is required.
8. If the measured clearance is out of specification, the valve shim must be replaced with one that will satisfy the clearance specifications.

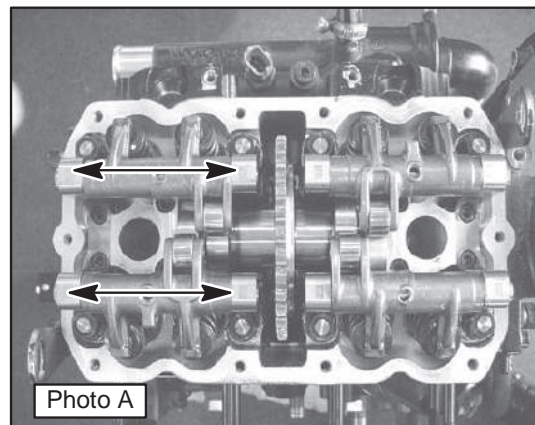

Photo A

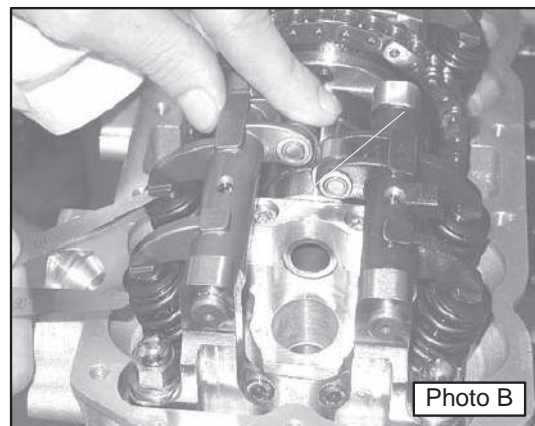

Photo B

VALVE CLEARANCE SPECIFICATION

INTAKE VALVE: .08 - .15MM (.003 - .006)

EXHAUST VALVE: .18 - .25MM (.007 - 0.10)

MAINTENANCE

Valve Clearance Adjustment Procedure - Continued

9. Install the Valve Compression Tool, PN-46991, under the rocker arm and over the top of the valve. Push the lever down, and extract the shim using a magnet.

CAUTION:

Do not compress the valve into the piston face. Do not damage or move the valve keepers.

10. Measure the original shim and determine the shim, smaller or larger, that will satisfy the clearance specification.

Available valve clearance shims.

Part Number	Shim Thickness (mm)
0451357	2.50
0451358	2.55
0451359	2.60
0451360	2.65
0451361	2.70
0451362	2.75
0451363	2.80
0451364	2.85
0451365	2.90
0451366	2.95
0451367	3.00
0452023	3.05
0451368	3.10
0451369	3.15
0451370	3.20
0451371	3.25
0451372	3.30
0451373	3.35
0451374	3.40
0451375	3.45
0451376	3.50
0451377	3.55
0451378	3.60
0451379	3.65
0451380	3.70

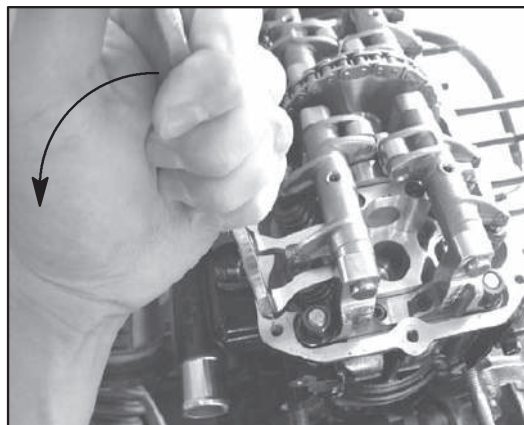

11. After performing the valve adjustment procedure on the MAG cylinder valves, rapidly tap the start button to rotate the engine to TDC - COMPRESSION stroke on the PTO cylinder.
12. Perform the valve adjustment procedure on the PTO cylinder valve train.
13. When completed, reinstall the valve cover. Tighten fasteners to 7 ft.lbs. (10 Nm).
14. Reinstall the phase sensor, ignition coil, and fuel injector wiring harness connectors.

MAINTENANCE

Engine Oil Level Check

NOTE: Always check the oil level with the watercraft level and the engine COLD.

1. Start engine and run for no more than 30 - 45 seconds.
2. Remove the oil dipstick from the top of the oil storage tank. Wipe clean with shop towel.
3. Re-insert the dip stick into the oil storage tank, but do not thread into tank. Remove the dipstick, and check oil level.

The oil level should be between the MIN and MAX marks. The volume between the MIN and MAX marks is .5 US Quarts (.5L).

The oil level will rise as the engine warms up to operating temperature, but **SHOULD NEVER RISE PAST THE OVERFILLED MARK.** Remove oil from tank if level is above MAX mark after warming engine to operating temperature.

Warming the engine up can be accomplished by installing a flush kit. Never exceed 2000 RPM when connected to a flush kit.

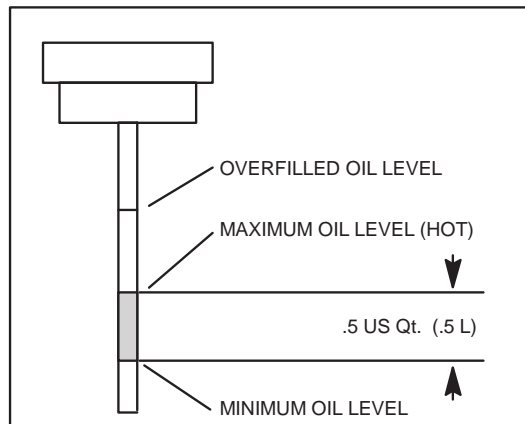

CAUTION:

Never allow the oil level to exceed the OVERFILLED OIL LEVEL mark on the top of the dipstick. Severe engine damage may occur.

ENGINE OIL SPECIFICATION

POLARIS MARINE PS-4 SYNTHETIC 15W-50

PN: SEE PAGE 2.4

ROUTINE OIL CHANGE: 3.4 - 3.7 US QUARTS
3.3 - 3.5 LITERS

NEW ENGINE: 3.9 - 4.2 US QUARTS
3.7 - 4.0 LITERS

BREAK IN: 12 HOURS

EVERY 25 HOURS AFTER BREAK IN PERIOD

Oil Change Procedure

1. Remove the oil fill cap located on the top of the oil storage tank.
2. Using a oil extraction / storage tool, insert the hose into the oil storage tank.

NOTE: To prevent oil foaming, a baffle is located inside the tank. Verify the hose passes through one of the baffle holes and reaches the bottom of the tank.

3. Extract ALL of the oil out of the storage tank into the storage container. Remove the hose, and replace the cap when all of the oil is removed.

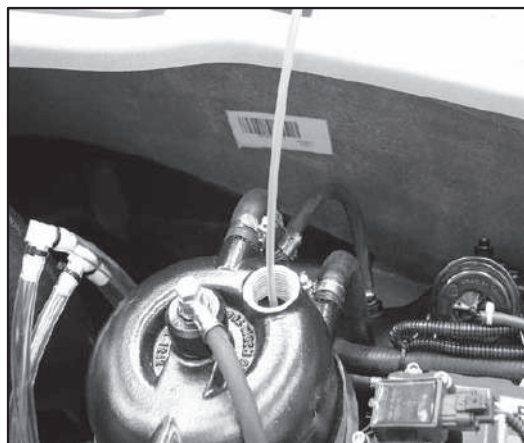

MAINTENANCE

Oil Change Procedure

4. Remove each of the two fuel injector and ignition coil wiring harness connectors.
5. Remove the upper oil feed hose from the top of the oil storage tank. Locate either a two-liter plastic bottle or a 5-foot length of hose with a male-to-male hose coupler.

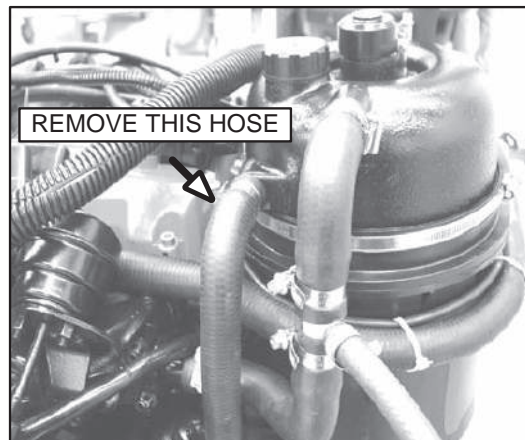

6. Insert the oil supply hose into the two-liter bottle inside the engine compartment, or, insert the coupler into both ends of the hoses and hang the entire length of hose over the side of the watercraft. Position this hose into a oil pan or oil containment container.
7. Insert the safety lanyard into the stop switch. Press and hold the start button for no more than 15 seconds. Release the start button for at least 30 seconds. Repeat this process three to four times, or until little or no oil is pumped out of the sump and into the container.



8. Locate the oil filter cover cap. Remove the cap and remove the o-ring and filter element. Replace filter element and o-ring with new parts.
9. Reinstall oil filter cover cap and torque to 24 Nm (17 ft.lbs.)
10. Clean oil tank fitting with brake cleaner or acetone, then reinstall the oil supply hose to the oil storage tank. Torque gear clamp to 30 in.lbs.
11. Fill to oil tank with 3.4 - 3.7 qts. (3.3 - 3.5 L) of Polaris PS-4 Synthetic Marine engine oil.

NOTE: Never add more than 3.7 qts. (3.5 L)

12. Reconnect the fuel injector and ignition coil wiring harness connectors.
13. Start engine and idle for 30 seconds. Stop engine and re-check engine oil level.
14. Add engine oil until level is at the low mark on dipstick.

NOTE: The oil level will increase as the engine warms up to operating temperature.

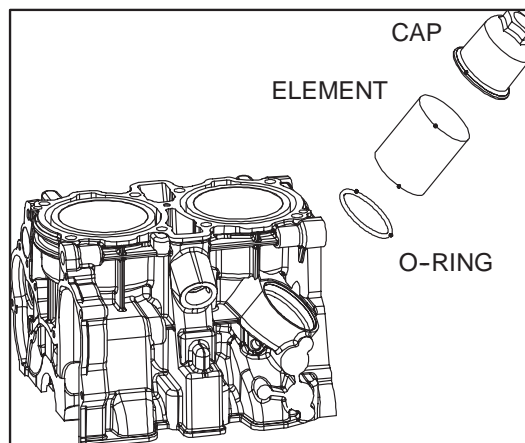

MAINTENANCE

Engine Coolant Level

The engine, oil cooler, and turbine bearing housing are cooled by an internal cooling system. A 50 / 50 mixture of propylene glycol (environmentally safe coolant) and distilled water must be used in warm-weather states. A 60 / 40 mixture of propylene glycol and distilled water can be used in cold-weather states and where the temperature can drop below freezing.

The internal cooling system is a self-bleeding design. The lowest point in the circuit is located just below the water pump housing.

1. The coolant level must be maintained between the MIN and MAX marks on the side of the coolant expansion tank. (Never overfill the expansion tank.)

ENGINE COOLANT SPECIFICATION (Warm-Weather States)

POLARIS ENVIRONMENTALLY SAFE
COOLANT 50/50 MIXTURE

PN: SEE PAGE 2.4

DRY CAPACITY:

CHANGE INTERVAL: 4 Years

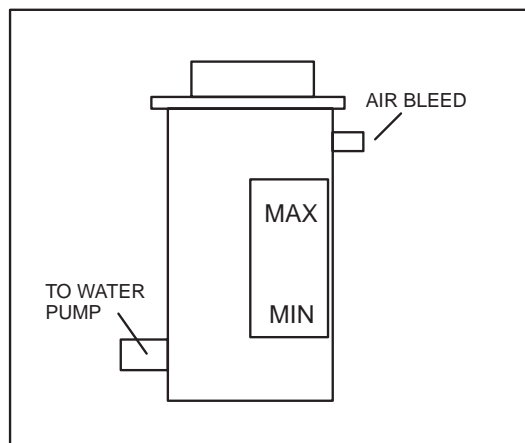

Engine Coolant Change Procedure

1. Remove the hose that connects the coolant expansion tank to the water pump cover. The engine coolant will drain into the engine compartment bilge.
2. Re-attach the hose. Open the two hull bilge plugs. Place two containers directly under the bilge plugs.
3. Carefully lift the front of the boat to about 15 degrees up. Allow all of the coolant to exit the engine compartment.
4. Flush the bilge with clean water, and secure bilge plugs.
5. Obtain new engine coolant, and slowly fill the expansion tank to the MAX mark. Allow the system to purge the air out of the circuits. (Level will go down over short period of time.)
6. Repeat process two to three times. Never fill level above MAX mark.

NOTE: The coolant level will drop after the first several operation cycles.

MAINTENANCE

Engine Cooling System Pressure Test

1. Test the system pressure capacity by removing the air bleed hose that connects the expansion tank to the coolant outlet manifold on the intake-side of the engine.

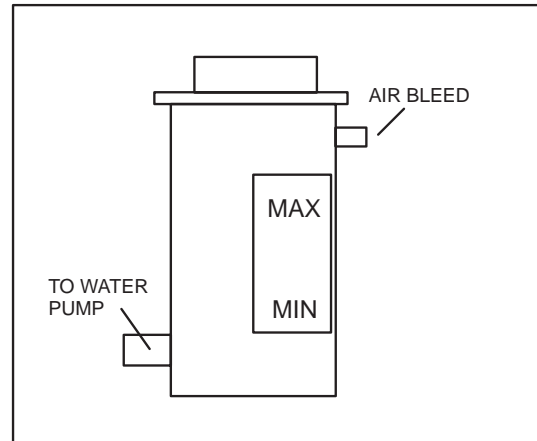

2. Insert a small bolt or plastic plug into the end of the bleed hose and secure with small gear clamp.

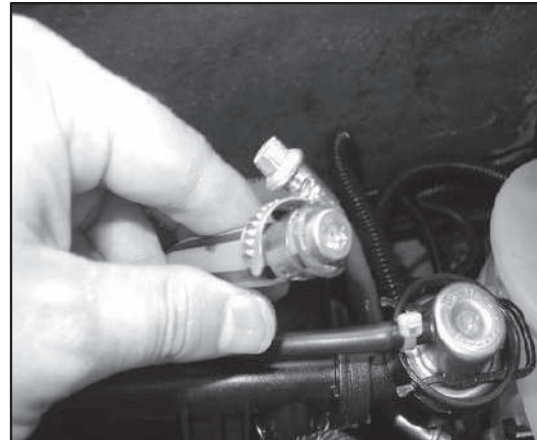

3. Attach a Mity Vac™ hand pump to the expansion tank air bleed nipple. Pressurize the expansion tank to 10 - 15 psi (.7 - 1 bar). The internal engine cooling circuit should maintain the pressure.

PRESSURE SPECIFICATION

10 - 15 psi (.7 - 1 bar)

4. A drop in pressure may indicate a worn or damaged hose, loose hose connection, or engine-related mechanical damage.

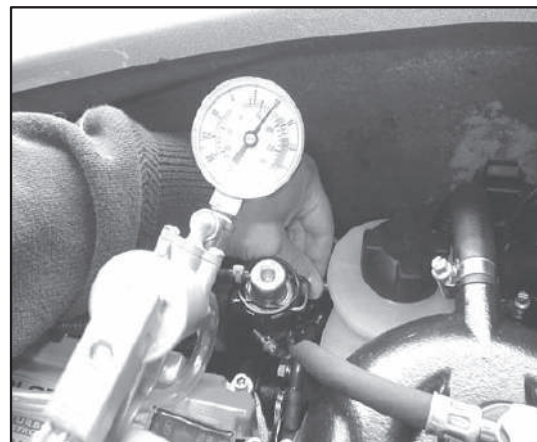

MAINTENANCE

Engine Compression Test

A cylinder compression test is one of the most accurate methods in determining the condition of internal engine components.

Always perform the compression test with a fully charged battery. Engine should rotate at least 300 RPM.

1. Remove both ignition coil packs from the valve cover. Remove both spark plugs.
2. Remove both fuel injector harness connectors.
3. Install the compression gauge into one of the cylinders.
4. Insert the lanyard and push the starter button for no more than 15 seconds. Obtain reading from gauge, then release gauge pressure.
5. Measure remaining cylinder.
6. Reassemble in reverse order. Tighten fasteners to specification.

COMPRESSION SPECIFICATION

140 ± 14 PSI (9.6 ± 1 BAR) @ SEA LEVEL
VERIFY BATTERY IS FULLY CHARGED

Fuel System Pressure Test

▲ WARNING

Wear safety glasses or a face shield for eye protection when working on the fuel system.

Test the fuel system by installing a fuel pressure gauge on to the inline Schrader Valve™.

1. Remove Schrader Valve™ cap and install pressure gauge.
2. Start engine. Take reading and remove system pressure from gauge.
3. Use a shop towel to prevent fuel spills.
4. Re install cap.

FUEL PRESSURE SPECIFICATION

43.5 psi + BOOST (3 bar + BOOST) @ IDLE
Approximately 59 PSI (4.1 bar) @ WOT

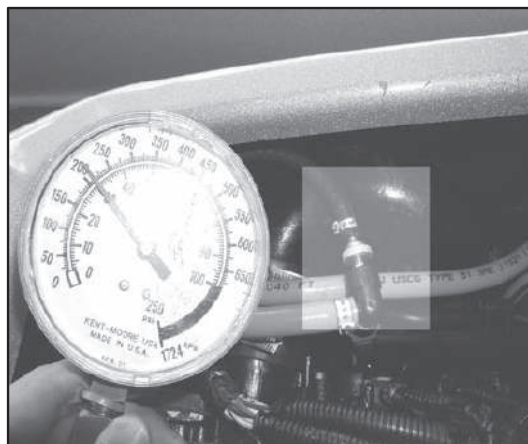

MAINTENANCE

Battery Safety

When removing and installing the battery, or when performing battery maintenance always heed the following warnings and cautions:

WARNING

Battery electrolyte is poisonous. It contains sulfuric acid. Serious burns can result from contact with the skin, eyes or clothing.

Antidote:

EXTERNAL - Flush with water.

INTERNAL - Drink large quantities of water or milk. Follow with milk of magnesia, beaten egg or vegetable oil. Call a physician immediately.

EYES - Flush with water for 15 minutes and get prompt medical attention.

Batteries produce explosive gases. Keep sparks, flame, cigarettes, etc. away. Ventilate when charging or using in closed space. Always shield eyes when working near batteries. KEEP OUT OF THE REACH OF CHILDREN.

CAUTION:

The battery must be removed from the watercraft for maintenance and charging. Battery electrolyte may spill and damage the watercraft.

WARNING

Always disconnect the black (negative) cable first. Electrolyte or fuel vapors may be present in the engine compartment and a spark could ignite them which could cause personal injury. When re-installing battery connect black (negative) cable last.

Whenever installing batteries, care should be taken to avoid the possibility of explosion resulting in serious burns. Always connect the positive (red) cable first and the negative (black) cable last. When working with batteries, always wear safety glasses or a face shield and protective gloves. Battery electrolyte contains sulfuric acid and is poisonous! Serious burns can result from contact with the skin, eyes or clothing. **ANTIDOTE:** External - Flush with water. Internal - Drink large quantities of water or milk. Follow with milk of magnesia, beaten egg, or vegetable oil. Call physician immediately. Eyes - Flush with water for 15 minutes and get prompt medical attention.

Battery Removal

1. Remove velcro straps holding electrical box and battery in position.
2. Remove cover from top of battery.
3. Remove battery vent tube from battery.
4. Disconnect black (negative) battery cable first.
5. Disconnect red (positive) battery cable next.
6. Lift battery out of watercraft, being careful not to tip it sideways and spill any electrolyte.

CAUTION:

Battery electrolyte can damage the watercraft finish if spilled. If an electrolyte spill occurs, apply a generous amount of baking soda to the area and then rinse with fresh water.

MAINTENANCE

Replenishing Battery Fluid

The fluid level should be kept between the upper and lower level marks.

To refill use only distilled water. Tap water contains minerals which are harmful to a battery.

Battery Connections

Battery terminals and connections should be kept free of corrosion. If cleaning is necessary, remove the corrosion with a stiff wire brush. Wash thoroughly with a solution of baking soda and water (one tablespoon of baking soda to one cup of water). Rinse well with tap water and dry off with clean shop cloths. Coat the terminals and terminal bolts with Nyogel™ grease.

**Nyogel™ Grease
PN 2871329**

Battery Charging

CAUTION:

The battery must be removed from the watercraft for maintenance and charging. Battery electrolyte may spill and damage the watercraft.

Always disconnect the black (negative) cable first. Electrolyte or fuel vapors may be present in the engine compartment and a spark could ignite them which could cause personal injury. When re-installing battery connect black (negative) cable last.

▲ WARNING

Keep the battery away from sparks and open flames during charging because the battery gives off gases which are explosive. If you smell fuel do not attempt to charge the battery. When using a battery charger connect the battery to the charger before turning on the charger. This reduces the possibility of sparks at the terminals which could ignite the battery gases. Do not connect charger cables to the battery unless the charger is unplugged.

1. Remove caps from cells. Add distilled water if necessary to bring electrolyte up to proper level.
2. Connect battery to a charger. Set charging rate at 1.9 amps (maximum) and charge battery for ten hours.

CAUTION:

During charging, if the electrolyte temperature rises above 115°F (45°C) or if battery feels hot when touched, reduce the charging rate to lower the temperature and increase the charging time.

3. After battery is charged, check fluid level. If it has dropped add distilled water to bring electrolyte up to proper level.
4. Check results of charging. The specific gravity of each cell must be 1.270 at room temperature. The voltage should be 14.5 - 15.5 V during charging; 12.2 - 12.8 V after charging.

**Specific Gravity
1.270 or greater - Each Cell**

Maintain
Between
Upper and
Lower Level
Marks

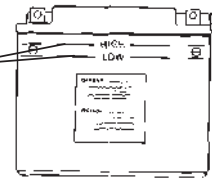

Top View of Battery

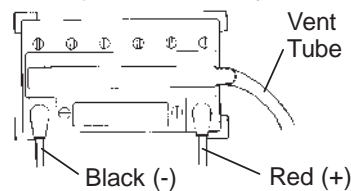

MAINTENANCE

Battery Installation

▲ WARNING

Always connect battery cables in the order specified. Red (positive) cable first, black (negative) cable last.

1. Install battery in its holder.
2. Install battery vent tube. It must be free from kinks, obstructions, or restrictions and securely installed. If not, battery gases could accumulate and cause an explosion. Avoid skin contact with electrolyte, severe burns could result.
3. Apply Nyogel™ grease to each cable bolt.

**Nyogel™ Grease
PN 2871329**

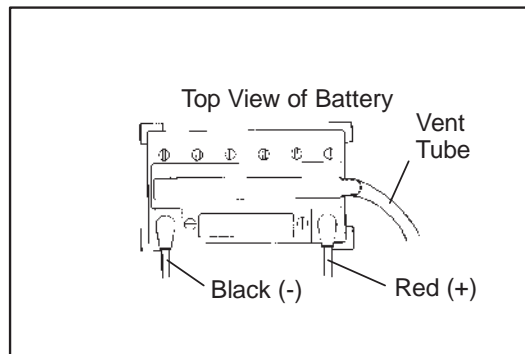

4. First, connect and tighten red (positive) cable.
5. Second, connect and tighten black (negative) cable.
6. Apply dielectric grease to each cable end and to terminal post area.
7. Reinstall battery cover and electrical box over battery and reconnect straps.
8. Verify that cables are properly routed.
9. Verify that vent hose is not kinked.

Battery Storage

1. Remove battery. Clean casing and terminals with baking soda and water (one tablespoon of baking soda to one cup water). Apply dielectric grease to battery terminals and all exposed cable connectors.
2. Top off battery with distilled water and charge to a specific gravity of 1.270 (test each cell). Recharge monthly as required to prevent battery discharge, sulfation, and freezing.
3. Store battery in a cool, dry place out of direct sunlight.

MAINTENANCE

Spark Plug

USE ONLY RESISTOR-TYPE SPARK PLUGS! SEVERE ENGINE PROBLEMS MAY OCCUR IF NON-RESISTOR-TYPE SPARK PLUGS ARE INSTALLED.

1. Inspect electrodes for wear, carbon buildup, or fouling (wet oily residue). Replace plugs if edges of electrodes are rounded or eroded.
2. Clean with electrical contact cleaner or a glass bead spark plug cleaner only. A wire brush or coated abrasive should not be used.
3. Measure gap with a wire gauge and refer to specifications. Adjust if necessary by bending the side electrode carefully.
4. Coat spark plug threads with a small amount of anti-seize compound.
5. Install spark plug and torque to 18ft.lbs.
6. Make sure spark plug caps are screwed completely onto end of plug wire.
7. Apply a small amount of Nyogel™ grease to inside of plug caps and install.
8. Push cap onto plug until cap “snaps” into place. Torque ignition coil fasteners to specification.

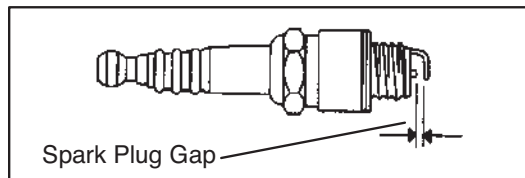

Spark Plug Gap

CHAMPION RC7PYCB

.6 - .7 mm (.025 - .030 in.)

Fuses

MODEL	FUSES	COMPONENT	LOCATION
MSX 110 / 150	2AMP	NGI Gauge	Harness Pod
	10AMP	Fuel Pump	
	15AMP	Ignition System	
	15AMP	Main Relay	
	15AMP	Main Relay	
	15 AMP	Main Relay	
	30AMP	Alternator	

MAINTENANCE

Exhaust Cooling Injector Maintenance

The exhaust pipe rubber hoses and muffler are cooled by injecting a small amount of water injected through an orifice from the freshwater cooling system into the exhaust stream. The orifice should be inspected and cleaned periodically to ensure proper cooling of the exhaust muffler and connector hoses. Be sure hoses are not restricted (kinked or collapsed internally).

CAUTION:

1. Loosen clamp connecting hose to fitting and remove hose.

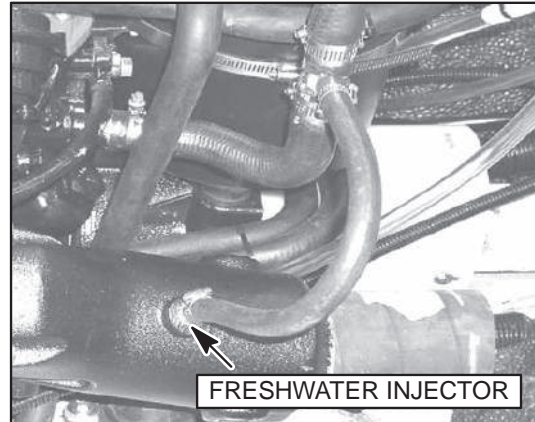

2. Inspect and clean orifice.
3. Reinstall cooling hose.

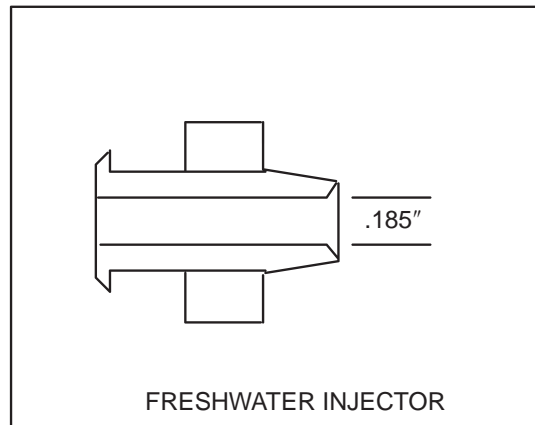

Throttle Cable Adjustment

The throttle cable connects the throttle flipper with the Pedal Position Unit (PPU). The cable is located underneath the steering helm.

1. Turn adjuster clockwise to loosen the throttle flipper freeplay. Turn counter-clockwise to tighten flipper freeplay.

NOTE: Verify throttle cable is not kinked after performing procedure.

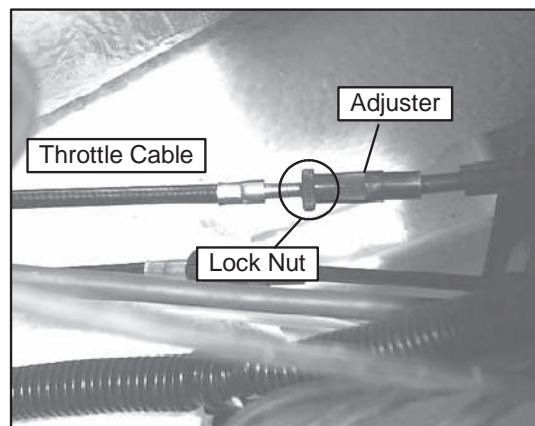

MAINTENANCE

Gasoline Safety

▲ WARNING

Gasoline is highly flammable and explosive under certain conditions.

- ◆ Always exercise extreme caution whenever handling gasoline.
- ◆ Always refuel with the engine stopped and outdoors or in a well ventilated area.
- ◆ Do not smoke or allow open flames or sparks in or near the area where refueling is performed or where gasoline is stored.
- ◆ Do not over fill the tank. (Do not fill the tank neck.)
- ◆ If you get gasoline on your skin or clothing, immediately wash it off with soap and water and change clothing.
- ◆ Never start the engine or let it run in an enclosed area. Gasoline powered engine exhaust fumes are poisonous and can cause loss of consciousness and death in a short time.
- ◆ Shut off fuel valve (if applicable) whenever the watercraft is stored, parked, or transported.

Fuel Lines / Vent Lines

1. Check fuel lines and vent lines for signs of wear, deterioration, damage or leakage. Replace if necessary. Ensure that clamps are tight.
2. Be sure all lines are routed properly and secured with cable ties away from any moving parts.

CAUTION:

Make sure lines are not kinked or pinched.

Water Separating Filter

The water separating filter requires no maintenance.



In-Line Fuel Filter

The inline fuel filter is located in front of the fuel tank and is connected to the fuel supply hose. Verify arrow points towards the engine (downstream) when installing new filter.



MAINTENANCE

Bilge Siphon System

1. Clean bilge siphon pickup screens whenever debris are present.

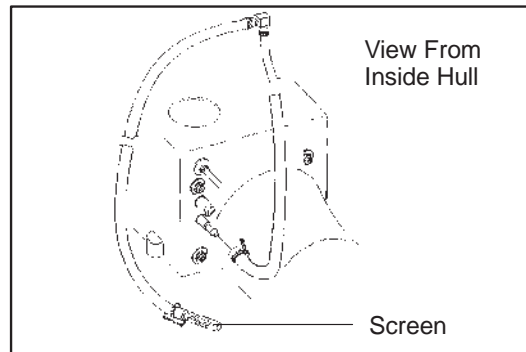

2. Inspect the .040" hole in fitting elbow. It must be clear to prevent siphoning of water into bilge.
3. Inspect all tie straps to be sure they are tight and in position.

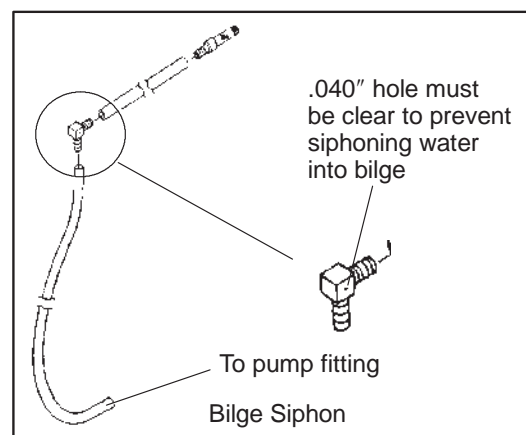

Bilge Drain Plugs

1. Inspect bilge plug for cracks or damage from over-tightening.
2. Periodically inspect sealing O-ring and replace if worn or damaged. Inspect drain plug, gasket, keeper strap and tightness of screws.
3. Inspect bilge drain plug mounting bolts for proper torque. Torque mounting bolts to 8 - 10 in.lbs.

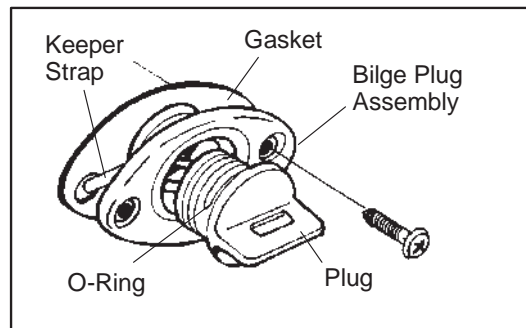

MAINTENANCE

Cooling Water Pickup Screen

Inspect the screen in the pump stationary nozzle for debris and clean if necessary.

Fasteners

Inspect all fasteners in the pump area and make sure they are tight. These include the steering nozzle mounting bolts, steering cable bolt, trim nozzle mounting bolts (where applicable), and all reverse mechanism fasteners (where applicable). Inspect pump mounting nuts and extension housing bolts. Refer to specific torque values listed in the General Information section or Final Drive/Jet Pump section.

Scoop / Ride Plate / Intake Grate

Verify fastener torque on the scoop, ride plate, and intake grate. Inspect all components for damage. Inspect the scoop sealing area for signs of black exhaust trails which indicate a leak in the sealant around the scoop. Even a small leak will ventilate the pump area, creating cavitation of the pump and reducing performance. If a leak is evident, remove the scoop and re-seal. Refer to Final Drive/Jet Pump section for procedures. Excess silicone sealant can be trimmed until flush with edges.

Impeller Clearance

▲ WARNING

Be sure the lanyard cord and lock plate are removed from the engine stop switch to kill the ignition or severe injury could result.

1. Remove intake grate.
2. Use a feeler gauge to measure impeller clearance along each blade in three spots. If measurement exceeds service limit, replace impeller. If clearance is excessive with a new impeller, the pump housing must be replaced.

Impeller Clearance

Standard .002-.008" (.05-.20 mm)
Service Limit .020" (.5 mm)

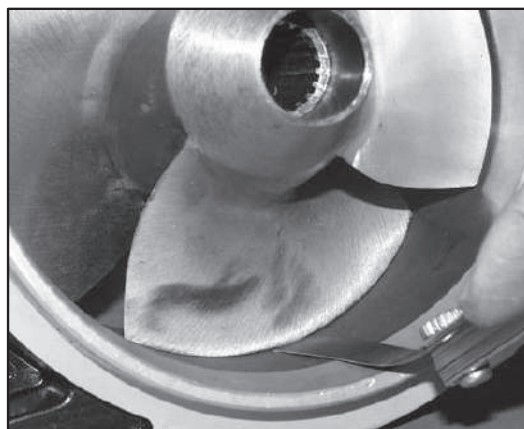
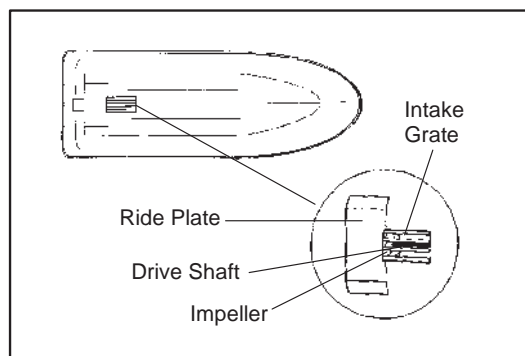
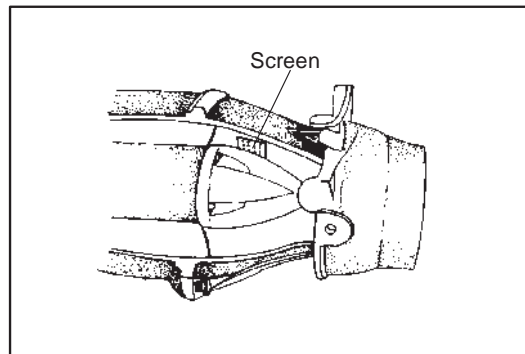

MAINTENANCE

Pump Housing Inspection

Inspect pump housing for excessive wear, cracks, or deep gouges. Replace if necessary.

Sacrificial Anode

The purpose of these anodes is to prevent corrosion of metal parts due to electrolysis. The mounting surfaces must be clean and the mounting bolt tight to maintain a good connection between the pump and anode.

1. Periodically inspect anode for excessive wear. If wear exceeds 50% of original size, replace anode.
2. Check bolt to be sure it is tight. If the bolt is loose, the anode is useless. Remove anode and clean mounting surfaces on pump and anode.
3. Apply dielectric grease to bolt threads and contact surfaces.
4. Tighten bolt securely.

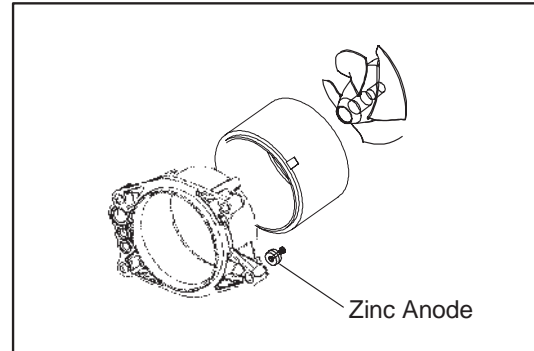

Nyogel™ Grease
PN 2871329

MAINTENANCE

Handlebar / Hand Grips

1. Pull and twist on hand grips to ensure they are not loose. If loose or worn, the handlebar with grip assembly must be replaced.
2. Reference chapter six for disassembly procedures.

Handlebar Post

1. Move handlebars up and down and side-to-side to check for excessively worn bushings. If wear is excessive, steering arm can be re-adjusted on handlebar shaft. Reference chapter six for further information.

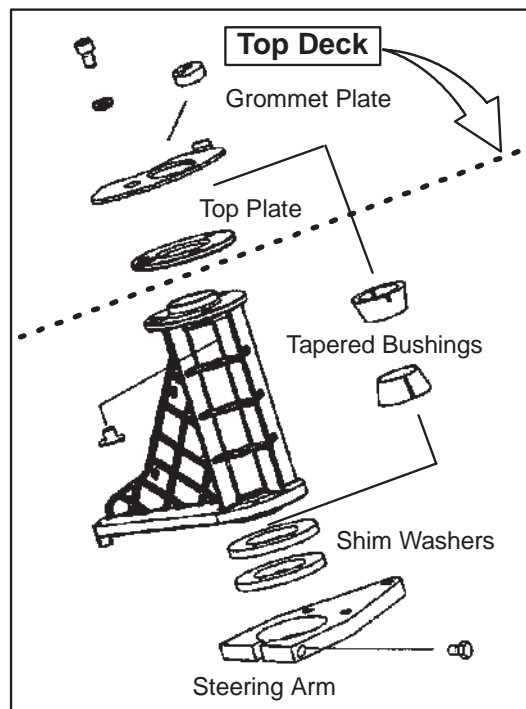

Fasteners / Parts / Hoses

Inspect the watercraft for any loose nuts, bolts, fasteners and hoses. Be sure that all hose clamps are tight. Replace cracked, damaged, or deteriorating hoses.

Intake Manifold Fastener Re-Torque

During the 12 hour break-in and first 25 hour maintenance check, the intake manifold fasteners must be checked for the correct torque.

- A = 13 ft.lbs. (18 Nm)
- B = 7 ft.lbs. (10 Nm)

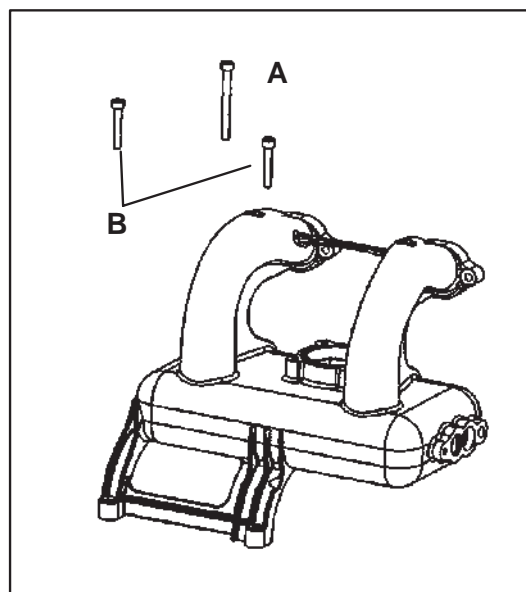

MAINTENANCE

Drain Plugs

A drain plug is located on the front of the intercooler and on the back of the intake manifold.

1. Intercooler drain plug. Apply marine grade silicone to threads when reinstalling. Hand tighten.

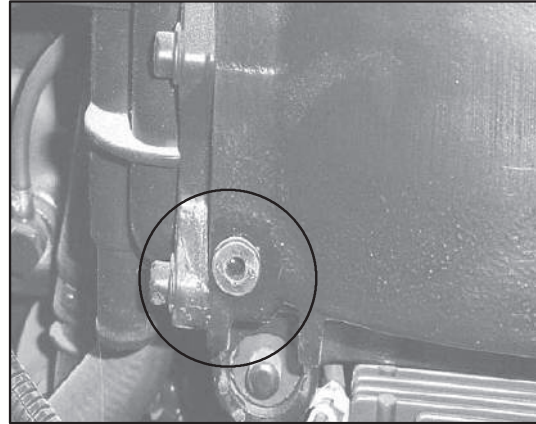

1. Intake manifold drain plug. Apply marine grade silicone to threads when reinstalling. Hand tighten.

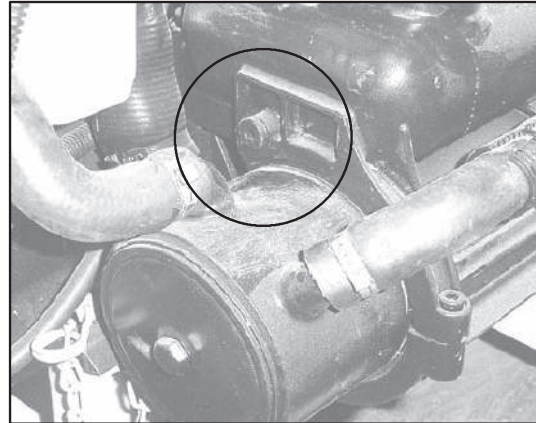

The drain plugs are designed to allow any water inside of the intercooler or air intake to escape in the event where the watercraft has rolled over and taken on water.

NOTE: Never operate the watercraft without the drain plugs installed! Severe engine damage may occur.

MAINTENANCE

Off - Season Storage

The off-season storage period is determined to be the time when 1. The watercraft will not be used for 30 or more days, or, 2. The end of the normal riding season where the watercraft will be "winterized" for storage.

1. Remove the engine oil and replace with new.
 - Used oil contains water, and un-burned fuel. When left inside the engine for extended periods of time, internal engine corrosion can occur.
2. Flush the freshwater cooling circuit.
 - Flushing the freshwater cooling circuit will remove salt, vegetation, and any other foreign material trapped within the circuit.
3. Check the condition of the engine coolant.
 - Using a coolant tester, commercially available, test the boil over and freeze temperature of the engine coolant. A 50/50 mixture of distilled water to propylene glycol should yield a freeze temperature of approximately -26°F .
 - A 60 / 40 mixture (coolant -to - distilled water) should be used where the water temperatures remain cool throughout the year and where the air temperature drops below -26°F .
4. Top off the fuel tank with fresh fuel.
 - A full fuel tank will prevent the formation of moisture and mold inside the tank.
5. Add Polaris Premium Fuel Stabilizer, PN 2870652, to the fuel tank. Follow the mixing instruction outlined on the bottle's label.
 - Fuel begins to break down and form varnish after 30 days. Adding stabilizer will prevent fuel from breaking down.
6. Flush the engine compartment bilge with clean water.
 - Cleaning the engine compartment bilge will prevent the growth of bacteria and mold.
7. Store the watercraft with the bow angled upwards at an angle of at least 10 degrees.
 - Tilting the bow upwards will drain the water in the exhaust system as well as allowing any water in the footwells to drain.
8. Always leave the seat loosely installed.
 - Fresh air must be allowed to circulate inside of the engine compartment during storage periods.
9. Verify the battery is fully charged. Store the battery in a cool, dry place. Attach a battery tender to the battery, or charge the battery once of month during the storage period.
10. Thoroughly clean the top deck and hull with mild detergent. Wipe dry and apply wax or furniture polish to hull.



POLARIS[®] *WATERCRAFT*

MSX 110 / 150 Service Manual

Engine Removal / Installation

Engine Subassembly Removal	3.1 - 3.8
Engine Mount Removal	3.9 - 3.10
Engine Installation	3.10

ENGINE REMOVAL / INSTALLATION

Engine Removal and Installation

Several sub-systems must be removed before the engine can be extracted from the engine bay. These systems are:

- Intercooler and associated air intake hoses and components.
- Engine electrical harness.
- Oil storage tank assembly.
- Air intake and throttle body assembly.
- Heat exchanger mounting bracket and coolant-to-fresh water heat exchanger.
- Lubrication and cooling hoses.
- Exhaust pipe and manifold, with turbocharger unit.
- Pump assembly.

The use of an engine hoist or overhead crane system is required to both remove and install the engine assembly.

▲ WARNING

Always disconnect the positive (RED) and negative (BLACK) battery cables from the battery after removing the engine oil and prior to performing any engine work. Failure to do so may cause severe injury or death.

NOTE: The use of an engine hoist is strongly recommended for working on and removing the engine from the engine compartment. Place masking tape around the engine compartment - seat mating surface. Doing so will prevent nicking and scratching of the hull when the engine is removed.

1. Remove the engine oil from the engine. Reference CHAPTER 2.
2. Remove the engine coolant. Reference CHAPTER 2.
3. Remove the pump nozzles and pump stator assemblies. Pull the driveshaft and rear drive couple away from the engine drive coupler. Reference CHAPTER 6. (*Photo A*)

NOTE: Not all electrical connections can be disconnected without removing hoses, pipes or sub-systems. As components are removed, disconnect any electrical connections.

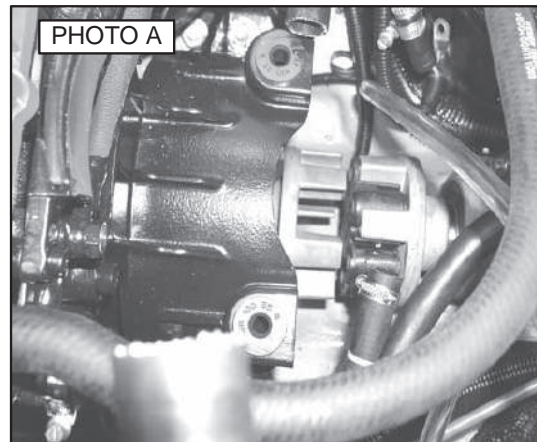

ENGINE REMOVAL / INSTALLATION

Engine Removal and Installation - Continued

4. Locate the fuel hose quick disconnect on top of the fuel rail. Wrap a shop towel around the disconnect and press the two tabs in while pulling up on the connector.
5. Remove the fuel supply and fuel return hoses from the fuel rail. (Identify hoses for re-assembly.)
6. Remove all of the hoses connected to the oil storage tank. (*Photo B*) Identify each hose and its location during removal.
7. Un-latch the TOP worm gear clamp that secures the oil storage tank to the rear of the engine.

NOTE: Do not loosen or tighten the lower worm gear clamp!

8. Lift the oil storage tank up and out of the cradle.
9. Remove the two lower tank hose connections. Identify each hose and its location during removal. (*Photo C*)
10. Remove the cyclone-to-sump oil return hose from the oil separator cyclone.
11. Carefully lift the oil storage tank out of the engine compartment.

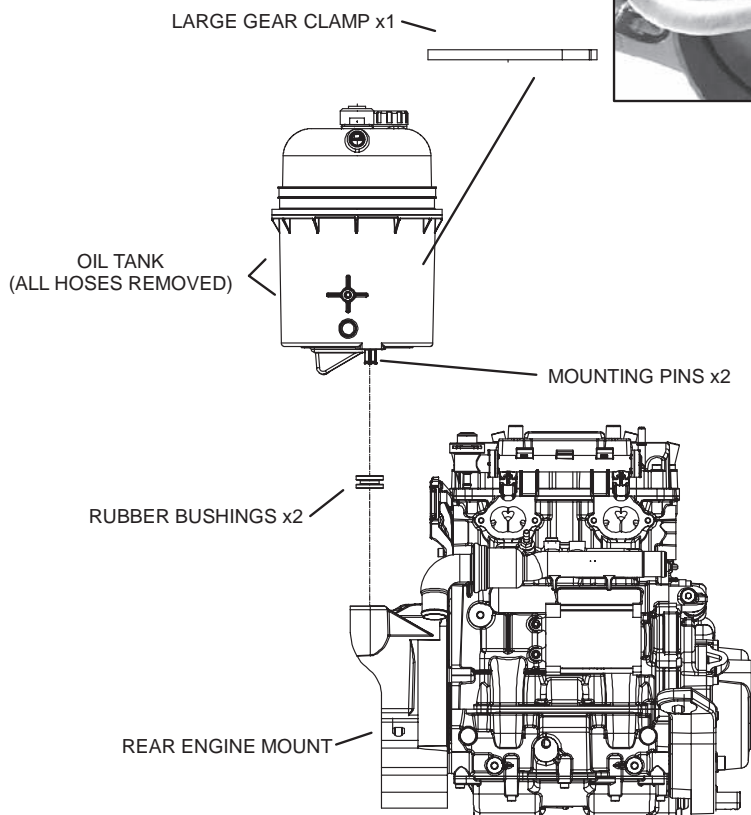
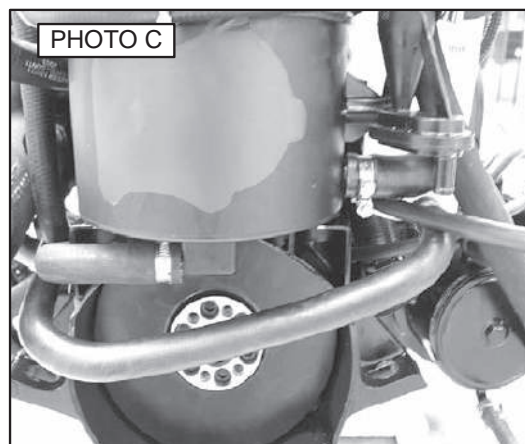
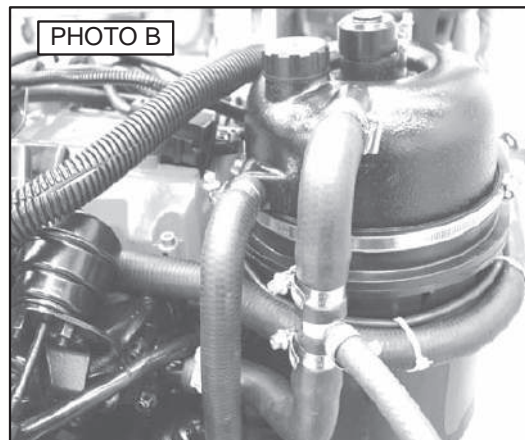

ENGINE REMOVAL / INSTALLATION

Engine Removal and Installation - Continued

12. Remove the hoses connected to the intercooler.
(Photo D)
13. Remove the fasteners and slide the intercooler forward towards the fuel tank.

NOTE: The intercooler cannot be removed until an engine hoist is connected to the engine and the engine assembly is moved rearward.

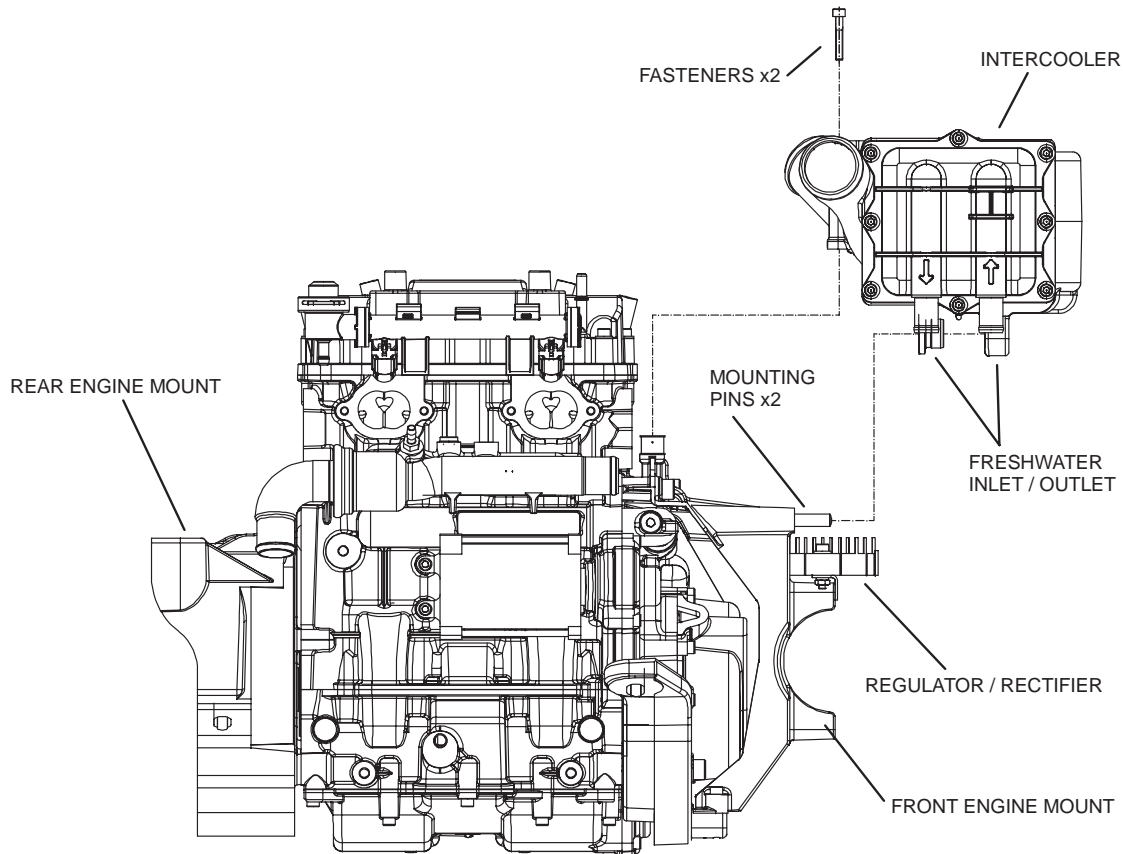
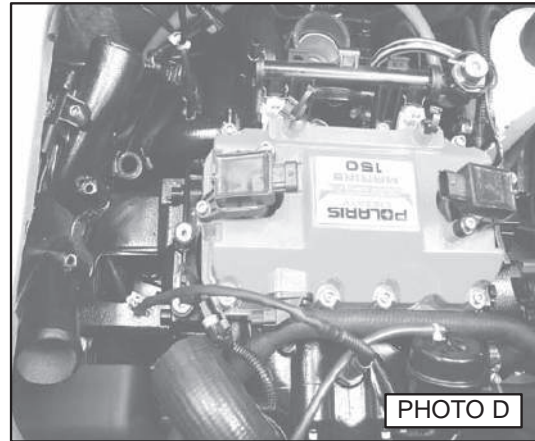

ENGINE REMOVAL / INSTALLATION

Engine Removal and Installation - Continued

14. Locate the engine coolant recovery tank. Remove the tank and associated hoses. Identify each hose during removal. *(Photo E)*
15. Remove the freshwater and engine coolant hose from the heat exchanger.

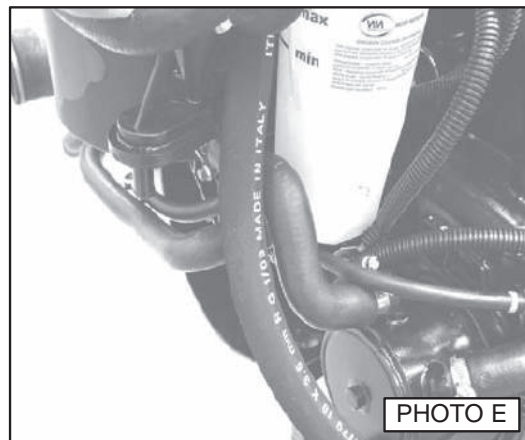

16. Locate the engine coolant outlet elbow located next to the intake manifold. Rotate the elbow down and towards the engine. *(Photo F)*

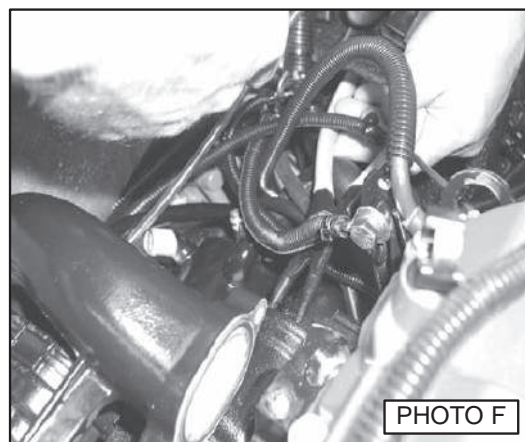

17. Remove the intake pipe, pop-off valve, fuel rail w/fuel injectors, and associated hoses. *(Photo G)*
18. Remove the intake manifold fasteners. Reference illustration on next page for fastener locations.

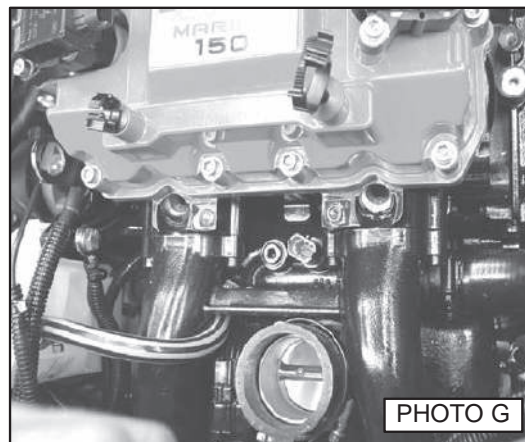

ENGINE REMOVAL / INSTALLATION

Engine Removal and Installation - Continued

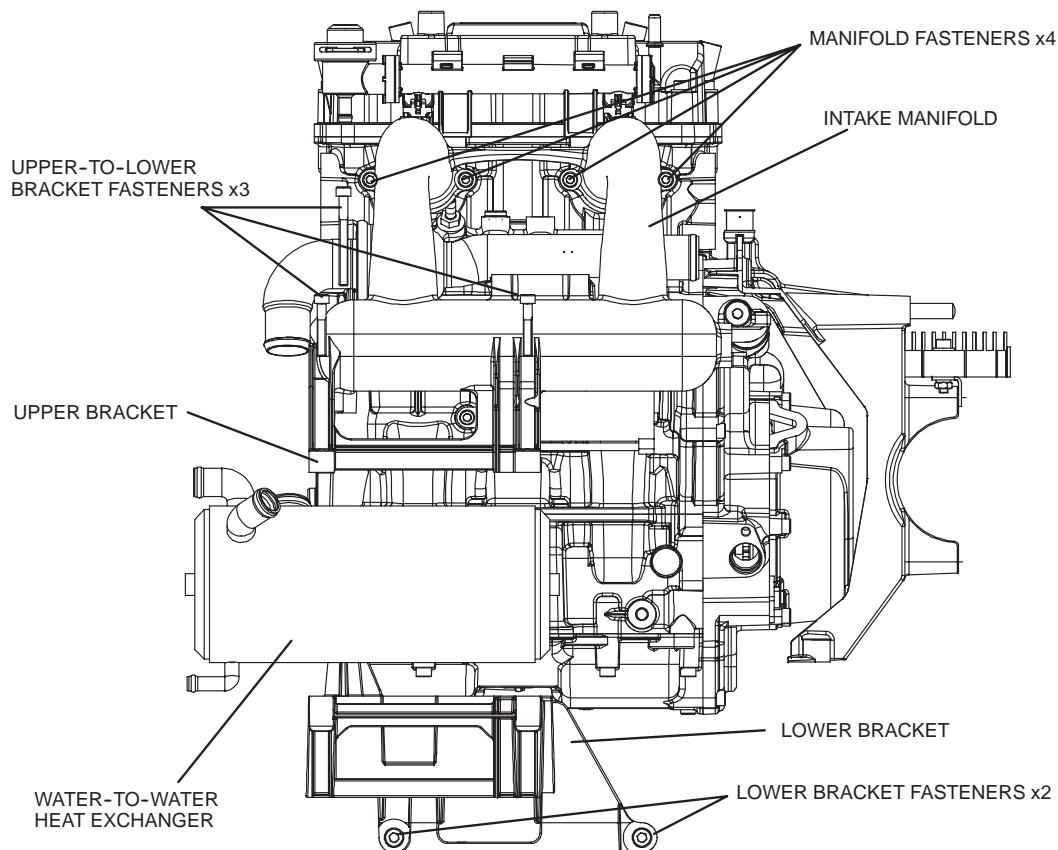

19. With the fasteners removed, carefully slide the intake manifold towards the rear of the engine compartment and out of the watercraft.
20. Slide the heat exchanger towards the rear, then remove from engine compartment. (*Photo H*)
21. Remove the two fasteners that secure the lower bracket to the engine. Remove the lower bracket.

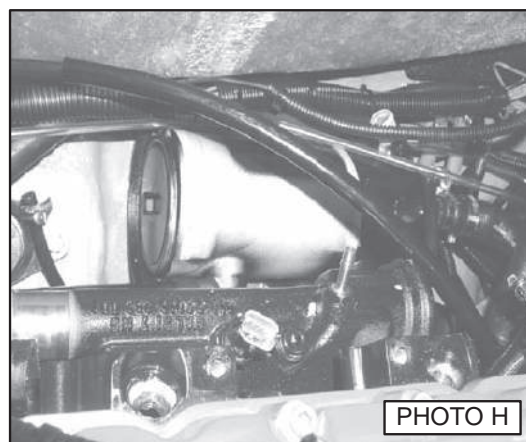

ENGINE REMOVAL / INSTALLATION

Engine Removal and Installation - Continued

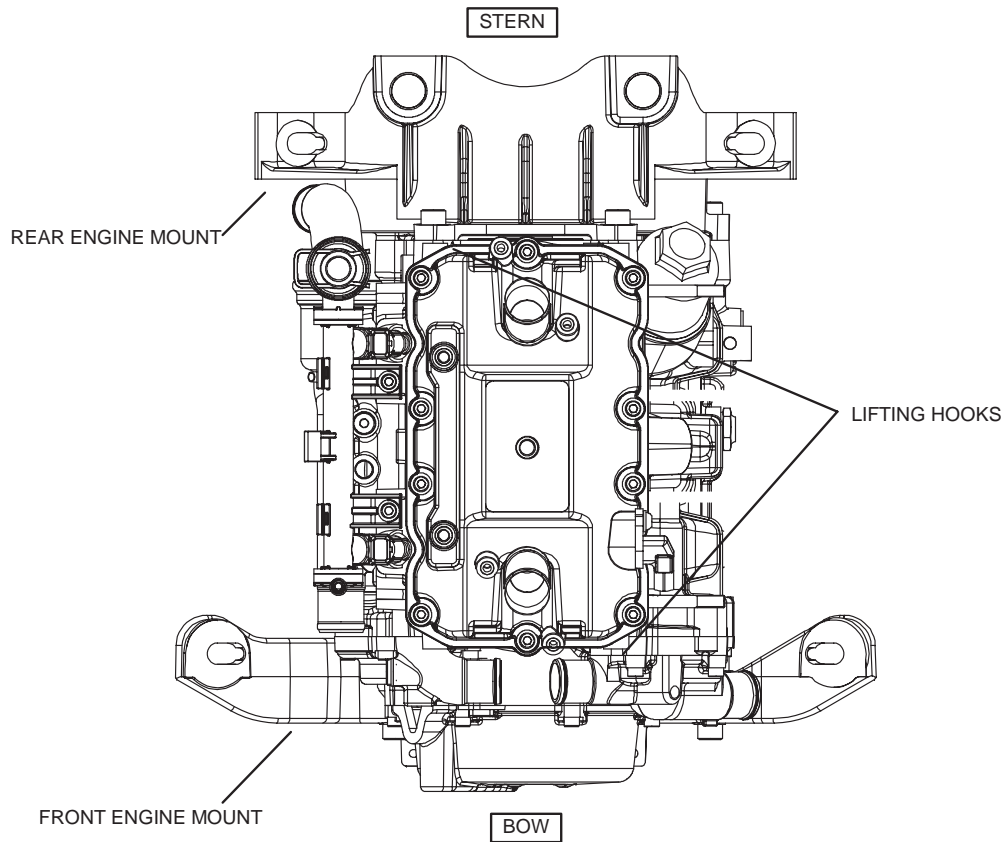

22. Locate and remove the four engine mounting nuts and washers. (Photo J) (Front Left Mount Shown)

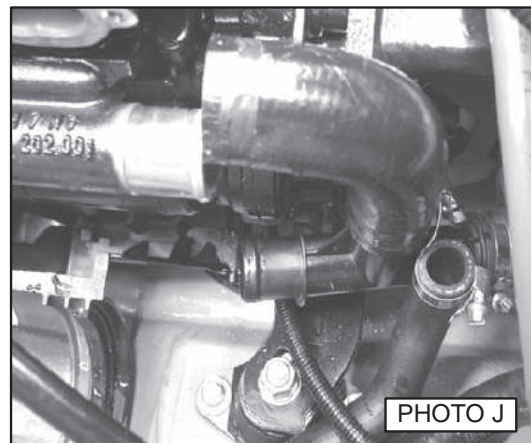

ENGINE REMOVAL / INSTALLATION

Engine Removal and Installation - Continued

23. Attach hoist chains to the front and rear lifting hooks. Verify hoist will lift engine up evenly. (Photo K)

NOTE: The hoist chains must allow the engine to be moved in any direction and at any pitch.

CAUTION: The lifting hoist must be able to lift at least 250 lbs. (113 kg.)

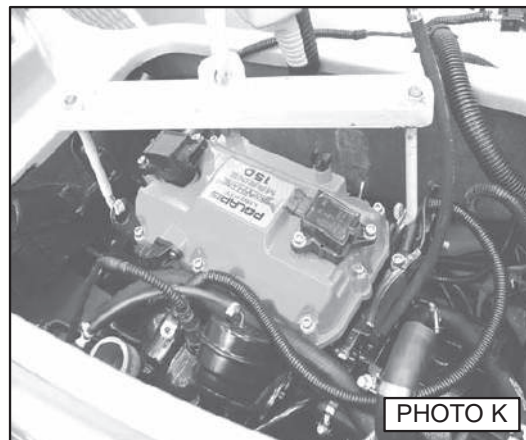

24. Carefully lift the engine upwards. Move the engine rearward once the engine straps clear the engine mount studs. With engine pushed back, remove the intercooler assembly.

25. Reposition the engine in the middle of the compartment. Carefully rotate the engine on to the intake-side. (Photo L)

NOTE: An assistant may have to lift the engine up while the engine is rotated on to its intake.

26. Lay the engine on to the intake side.

NOTE: The exhaust manifold, pipe, and turbine assembly must be removed from the engine in order to remove the core engine.

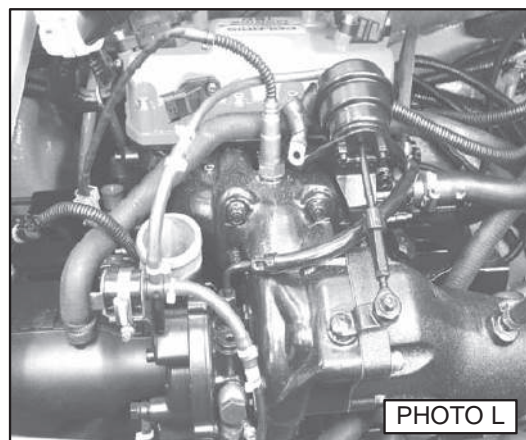

27. Remove the exhaust manifold from the engine. Identify any hoses or wiring harness components removed during the process.

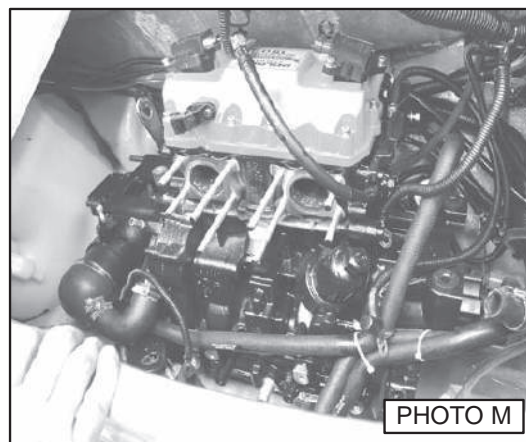

ENGINE REMOVAL / INSTALLATION

Engine Removal and Installation - Continued

28. Illustration of exhaust manifold-to-engine assembly.

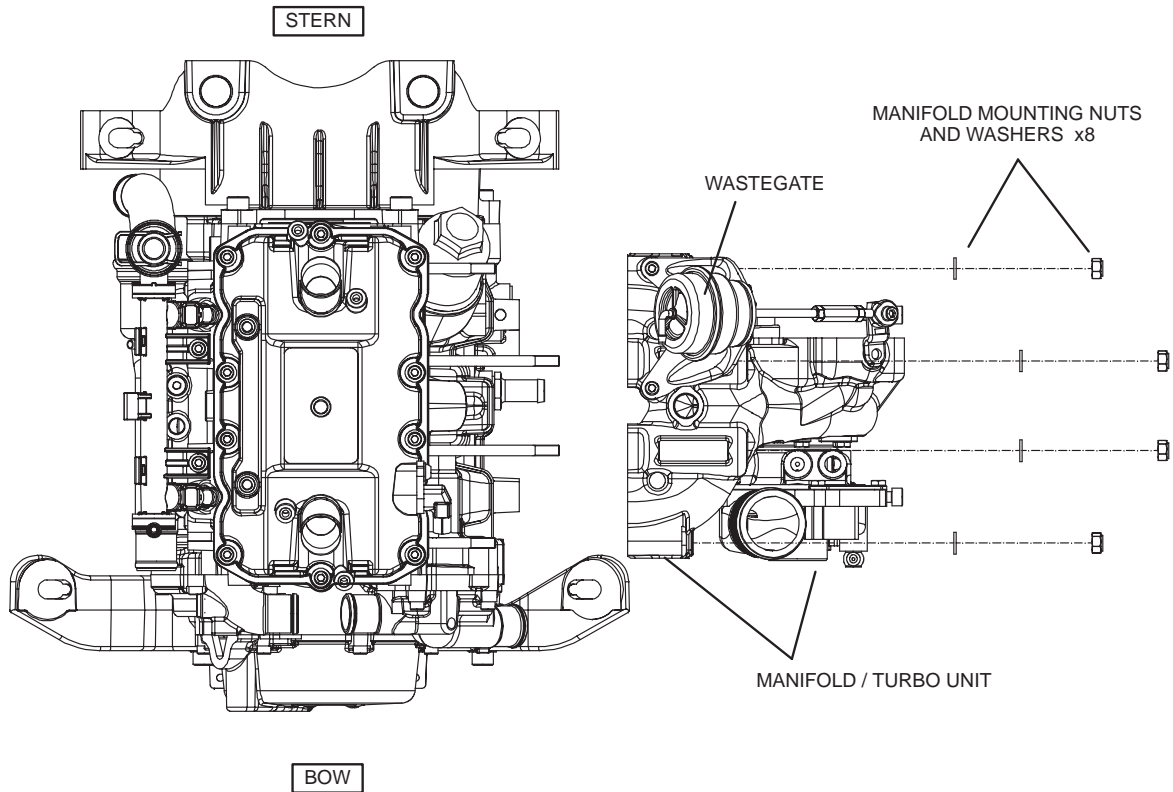

- 29. Reposition the core engine assembly into the center of the engine compartment.
- 30. Carefully lift the engine straight up and out of the compartment. (Photo N)

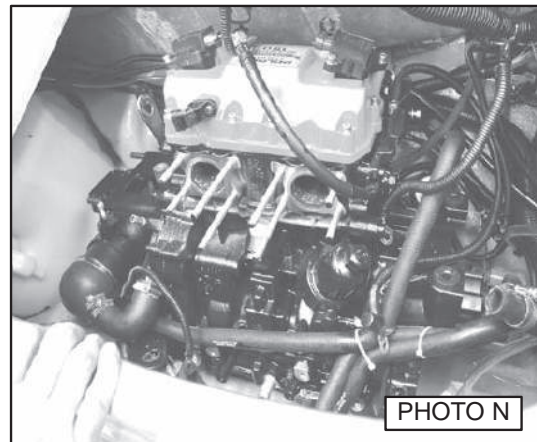

ENGINE REMOVAL / INSTALLATION

Engine Mounting Straps

The front and rear engine mounting straps are an integral part of the core engine assembly. Both straps must be removed from the engine to proceed with any engine disassembly.

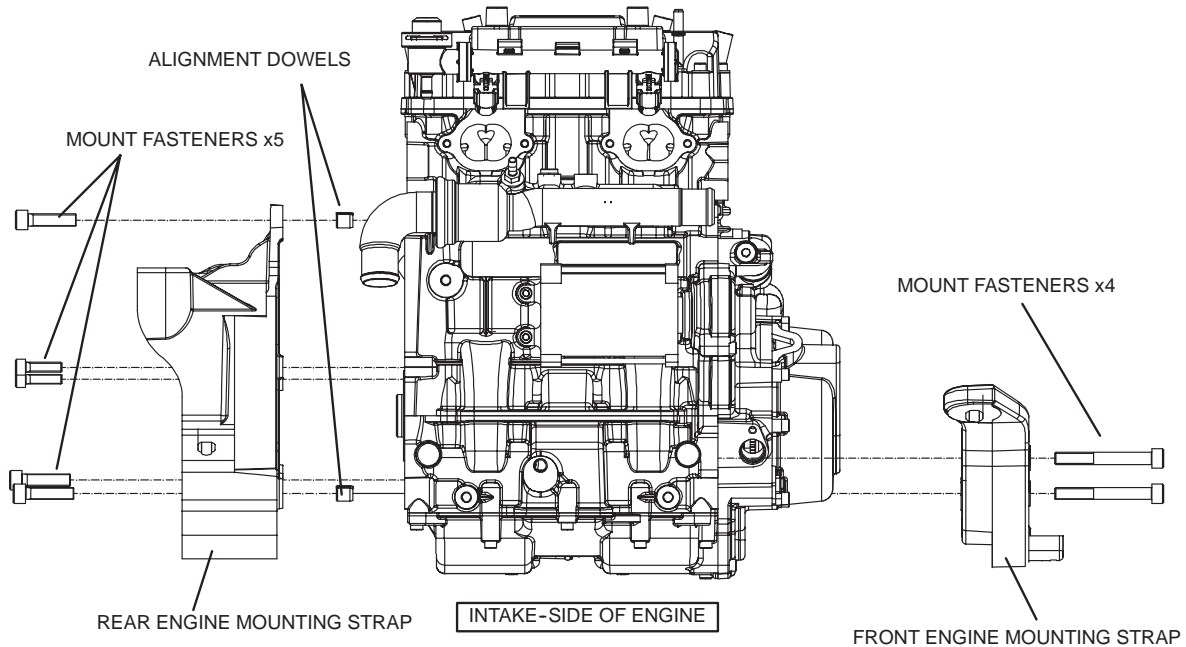

1. The engine must remain suspended by the hoist chains.
2. Remove the front engine mounting strap.
3. Insert a ratchet extension or metal dowel into the balance plate hole. Rotate the engine until dowel prevents engine from rotating counterclockwise. (Photo O)
4. Place a pry bar or large open end wrench across the coupler fingers. Rotate counter-clockwise to remove coupler from PTO shaft.

NOTE: Wrapping the pry bar or wrench with a towel will prevent damage to the coupler fingers.

5. With the balance plate still locked in position, continue with the removal of the PTO stubshaft and balance plate assembly.

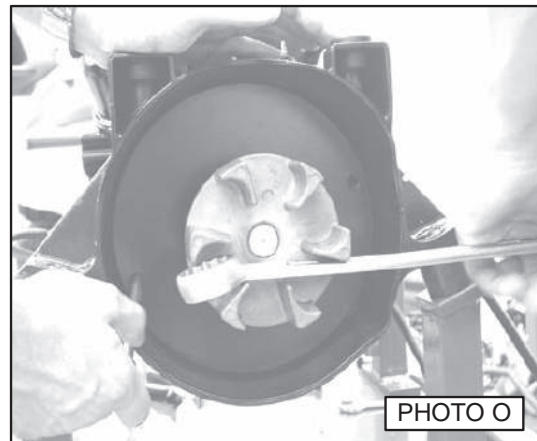

ENGINE REMOVAL / INSTALLATION

Engine Mounting Straps - Continued

- Loosen the rear engine mounting strap fasteners and remove the rear mounting strap. Remove the two alignment dowels from the engine case.
- Attach the ENGINE STAND ADAPTER PLATE, PN PW-46984, to the engine case. Reference the circled fastener locations in (PHOTO P).

NOTE: The curved radius found on the engine stand adapter plate must fit around the PTO seal and oil pump opening.

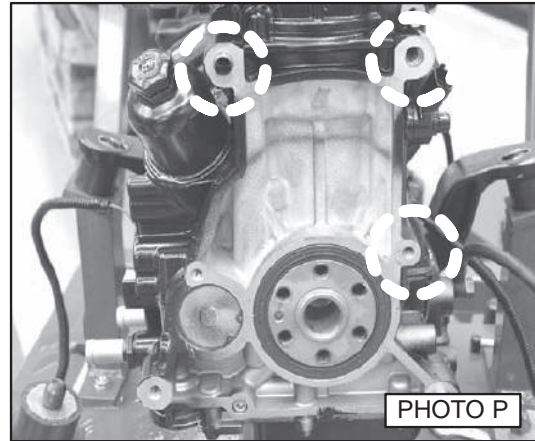
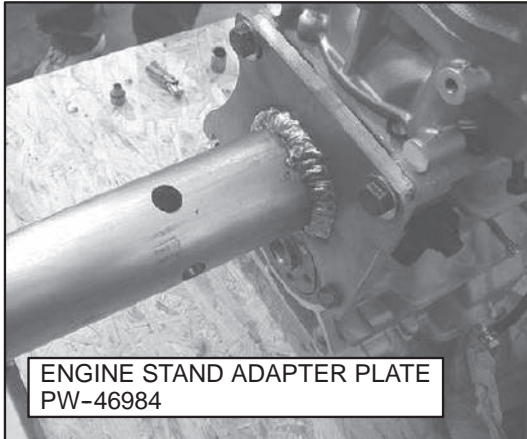

With the engine stand adapter plate installed, the engine can be secured to a rolling engine stand or work bench the using the BENCH MOUNT HOLDING FIXTURE, PN: J 03289-20.

Engine Installation

The installation of the engine and engine subsystems is the reverse of their removal. During engine installation, several important notes must be made.

- Always verify the correct number of engine mounting strap shims are installed on each engine mounting post. The correct number of shims is written next to each mounting post.
- The engine core is the first component that is installed into the engine compartment. Locate the intercooler underneath the top deck after the engine is placed inside the engine compartment, but prior to fastening the engine straps to the engine mounts. **THE INTERCOOLER CANNOT BE INSTALLED INSIDE THE ENGINE COMPARTMENT AFTER THE MOUNTING STRAP NUTS ARE INSTALLED.**
- Always verify that the engine does not interfere with critical routings such as the steering cable, reverse cable, cooling hoses, and main wiring harness.
- Always double-check each oil and cooling hose routing and connection before installing more components.
- Reference Chapter 4 and 6 for fastener torque and thread lubricant specifications.



POLARIS[®] *WATERCRAFT*

MSX 110 / 150 Service Manual

Engine Disassembly / Assembly

Engine Specifications	4.1 - 4.2
Engine Fastener Torque Specifications	4.3 - 4.6
Service Tools	4.7
Oil Filter Assembly	4.8
Valve Cover Assembly	4.9
Valve Train Assembly	4.10
Dry Sump Oil Pump Assembly	4.11
Thermostat Housing	4.12
High Pressure Oil Pump Assembly	4.13
Chain Guide and Chain Tensioner Assembly	4.14
Engine Case / Cylinder Head Assembly	4.15 - 4.16
Piston Assembly	4.17
Valve Assembly	4.18
Balance Plate / PTO Assembly	4.19
Crankshaft / Balance Shaft Assembly	4.20
Engine Disassembly	4.21 - 4.28
Engine Inspection	4.29 - 4.42
Engine Assembly	4.43 - 4.57
Timing Chain Installation / Timing Procedure	4.49 - 4.52
Freshwater / Internal Engine Cooling Systems	4.58
Thermostat , Water Pump & Seal Removal / Installation	4.59
Freshwater Cooling Circuit Illustrations	4.60 - 4.61
Internal Engine Cooling Circuit Illustrations	4.62 - 4.64
Oil Lubrication System	4.65
Crankcase Ventilation System	4.66
Oil Pump(s) Removal and Installation	4.66
Oil Lubrication Illustrations	4.67 - 4.69

ENGINE DISASSEMBLY / ASSEMBLY

Engine Specifications

Component	Specification
Engine Model Number	110 = ES075WLE-011 150 = ES075WLE-021
Maximum Engine Horsepower	110 and 150
Maximum Engine Torque	TBA
Engine Type	8 Valve SOHC Parallel Twin Cylinder w/Balance Shaft- Four Stroke
Displacement	750cc
Bore X Stroke	85 x 66mm (3.346" x 2.598")
Compression Ratio	9.0 : 1
Cylinder Compression @ Sea Level	140 ± 14 psi (9.6 ± 1 bar) @ Sea Level
Recommended Fuel	Premium Unleaded 91, 92, 93 Octane
Minimum Fuel Requirement	87 Octane with reduced engine performance.
Engine Oil Requirement	Polaris Marine Synthetic Four Stroke Engine Oil
Oil Grade Requirement	15W-50 Synthetic SI Rated
Engine Oil Capacity With Oil Filter Replacement Dry Engine (After Rebuild)	3.4 - 3.7 US Quarts (3.3 - 3.5 Liters) 3.9 - 4.2 US Quarts (3.7 - 4.0 Liters)
Cooling System Requirement	50 / 50 Distilled Water and Propylene Glycol (Warm Weather States) 60 / 40 Propylene Glycol - To - Distilled Water (Cold Weather States)
Cooling System Capacity Thermostat Opening Temperature System Pressure	3.5 US Quarts (3.3 Liter) 180° F (82° C) 14.6 PSI (1 Bar) / 17 PSI (1.2 Bar) Maximum System Pressure
Valve Timing (1mm Valve Lift) EV OPENS EV CLOSES IV OPENS IV CLOSES	52° BBDC 2° ATDC 14° BTDC 50° ABDC
Valve Diameter EV IV	29.5mm (1.161") 32.5mm (1.279")
Valve Seat Contact Width IV EV	1.1mm - 1.2mm (.043" - .047") 1.3mm - 1.4mm (.051" - .055")
Valve Face Width IV EV	2.0mm 2.0mm
Valve Margin Thickness IV EV	5.472mm (.2154") 5.463mm (.2150")
Valve Seat Angle	45°
Valve Outer Correction Angle	30°
Valve Inner Correction Angle	75°
Valve Clearance (COLD) IV EV	0.08 - 0.15mm (.003" - .006") 0.18 - 0.25mm (.007" - .010")
Valve Stem Diameter IV EV	5.465mm - 5.479mm (.2151" - .2157") 5.456mm - 5.470mm (.2148" - .2153")
Valve Guide Inside Diameter IV EV	5.5mm - 5.507mm (.216") 5.5mm - 5.509mm (.216")
Valve Stem Runout	.03mm (.001")
Valve Stem-To-Guide Clearance IV EV	.021mm - .044mm (.0008 - .0017") .030mm - .053mm (.0011 - .0020")

ENGINE DISASSEMBLY / ASSEMBLY

Engine Specifications - Continued

Component	Specification
Valve Spring Free Length INTAKE EXHAUST	38.2mm (1.5") 38.2mm (1.5")
Valve Spring Installed Length INTAKE EXHAUST	32mm (1.26") 32mm (1.26")
Cylinder Head Warpage Limit	.04mm (.001")
Cylinder Specifications BORE SIZE TAPER LIMIT OUT-OF-ROUND LIMIT WEAR LIMIT	85.00 - 85.01mm (3.34") .008mm (.0003") .008mm (.0003") N/A
Camshaft Specifications CAMSHAFT WIDTH IN CAM LOBE HEIGHT EX CAM LOBE HEIGHT MAXIMUM CAMSHAFT RUNOUT RADIAL PLAY BEARING HOLE I.D. CAMSHAFT AXLE O.D. CAMSHAFT CLAMP I.D.	108.85mm - 109.00mm (4.28" - 4.29") 48.553mm (1.911") 48.209mm (1.897") .05mm @ Sprocket / .02mm @ Base. (.001") .020mm - .050mm (.001") 25.972mm - 25.988mm (1.02") 19.991mm - 20mm (.787") 19.90mm - 19.98mm (.783")
Rocker Arm Specifications BEARING AXIAL PLAY ROCKER ARM I.D. ROCKER ARM SHAFT O.D. ROCKER ARM HOLDER BORE I.D. ROCKER ARM AXIAL PLAY	.013mm - .025mm (.0005" - .0009") 13.980mm - 13.991mm (.55") 9.994mm - 10mm (.393") 10mm - 10.009mm (.393") .16mm - .26mm (.006" - .010")
Crankshaft Specifications CRANKSHAFT DEFLECTION MAIN BEARING CLEARANCE BEARING CODES	.02mm - .04mm (.0007" - .0015") .03mm - .04mm (.0011" - .0015") 1.RED 2. YELLOW 3. BLUE 4. GREEN 5. BROWN
Connecting Rod Specifications BIG END OIL CLEARANCE SMALL END DIAMETER BEARING CODES	.01mm - .064mm (.0003" - .002") 20.995mm - 21.011mm (.826" - .827") 1.RED 2. YELLOW 3. BLUE 4. GREEN 5. BROWN
Balance Shaft Specifications AXIAL PLAY RADIAL PLAY BEARING DIAMETER RUN OUT	.15mm - .25mm (.005" - .009") .014mm - .066mm (.0005" - .002") 24.975mm - 24.990mm (.983") .014mm - .066mm (.0005" - .002")
Piston Specifications PISTON-TO-CYL CLEARANCE PISTON DIAMETER WEAR LIMIT PISTON PIN BOSS I.D. PIN O.D. PIN WEAR LIMIT	.041mm - .059mm (.0016" - .0023") 84.961mm - 84.979mm (Measured 15mm from bottom, 90° from pin. (3.34" - 3.345") .04mm (.001") 21.004mm - 21.009mm (.826" - .827") 20.995mm - 21.000mm (.826") .05mm (.001")
Piston Ring Specifications TOP RING INSTALLED RING GAP TOP RING GROVE CLEARANCE MIDDLE RING INSTALLED RING GAP MIDDLE RING GROVE CLEARANCE OIL RING INSTALLED END GAP OIL RING GROVE CLEARANCE	.2mm - .4mm (.07" - .015") .65mm - .955mm (.025" - .037") .2mm - .4mm (.007" - .015") .50mm - .805mm (.019" - .031") .2mm - .7mm (.007" - .027") .50mm - .910mm (.019" - .035")
Oil Pump Specifications OIL PUMP TYPES ROTOR TIP CLEARANCE (PRESSURE) OIL PRESSURE RELIEF VALVE OIL PRESSURE	Trochoid N/A SPRING FREE LENGTH = 2.7" (69mm) / PISTON O.D. = .43" (10.9mm) / PISTON LENGTH = 1.10" (27.7 - 28mm) 21 @ IDLE - 80 @ MAX PSI (1.5 - 5.5 BAR)

ENGINE DISASSEMBLY / ASSEMBLY

Engine Fastener Torque Specifications

Standard Torque Guide (mm)	FT. LBS.	Nm
5	2.5 - 3.6	3.4 - 4.9
6	4.3 - 5.7	5.9 - 7.8
8	10 - 14	14 - 19
10	18 - 25	25 - 34
12	32 - 45	44 - 61
14	54 - 72	73 - 98
16	85 - 114	115 - 155
18	122 - 166	165 - 225
20	166 - 240	225 - 325

Engine Specific Fastener Torque Specifications

Component	FT. LBS.	Nm	Notes	Fastener(s)
Cylinder Head Nuts Step 1 Step 2 Step 3	15 30 180°	20 40 180°	Apply Engine Oil to Threads.	M10 x 1.25 M8 x 50 M8 x 70 M8 x 90
Lower Crankcase Bolts Step 1 Step 3	12 18	16 24 - 25		
Gearcover - to - Engine Block	7	10		M6 x 20
Plug Elbow Connector	11	15		M12 x 1.5
Hose Connector in Lower Crankcase	30	40	Loctite 577	M18 x 1.5
Oil Filter Cover Cap	17	24		
Dry Sump Oil Filter Screen	7	10	Loctite 243	M6 x 20
Dry Sump Cover - to - Lower Crankcase	7	10		M6 x 20 M6 x 35 M6 x 60
Dry Sump Pump Gear	28	38	Loctite 272	M8 x 25
Dry Sump Pump - to - Cover	7	10		M6 x 20 M6 x 25
Dry Sump Hose Connector	7	10		M6 x 16
Balance Shaft Drive Gear Nut	51	70	Loctite 272	M10
Connecting Rod Bolts Step 1 Step 2 Step 3	7 14 90°	10 20 90°		M10 x 1.32
Camshaft Clamps	7	10		M6 x 40
Rocker Arm Holders	9	13		M6 x 20
Exhaust Manifold Studs Short Long	13 13	18 18	Copper Grease	M8 x 69 M8 x 118
Exhaust Manifold Nuts	17	24	Copper Grease	M8 Flange
Valve Cover	7	10		M6 x 45
Tensioner Rail Fastener	17	24	Loctite 243	M8 x 25
Chain Guide Rail Fastener	7	10	Loctite 243	M6 x 25
Chain Tensioner Plug Bolt	51	70		

ENGINE DISASSEMBLY / ASSEMBLY

Engine Specific Fastener Torque Specifications

Component	FT. LBS.	Nm	Notes	Fastener(s)
Water Pump Cover	7	10	Loctite 577	M6 x 20 M6 x 30 M6 x 35
Engine Coolant Outlet Manifold	7	10		M6 x 20
Engine Coolant Outlet Manifold Plug	7	10		
Turbocharger Coolant Return Banjo Bolt				
Expansion Tank Fasteners	7	10		M6 x 20
Engine Coolant Outlet Manifold - to - Expansion Tank Nozzle	7	10		

Turbocharger / Intercooler Specific Fastener Torque Specifications

Component	FT. LBS.	Nm	Notes	Fastener(s)
Segments	7	10		M6 x 16
Compressor Housing Clamping Lugs	7	10		M6 x 12
Oil Return Flange	7	10		M6 x 16
Turbocharger Lower Crankcase Bracket	17	24		M8 x 40
Turbocharger Bracket - to - Manifold	17	24		M8 x 50
Wastegate Actuator Locknut	7	10		
Wastegate Bracket - to - Manifold	7	10		Torx E8
Wastegate - to - Bracket	7	10		M6
Actuator Arm - to - Lever	7	10		M6 x 20
Intercooler Cover	6	9		M6 x 20
Intercooler Mounting Fasteners	7	10		M6 x 35

Intake Manifold Specific Fastener Torque Specifications

Component	FT. LBS.	Nm	Notes	Fastener(s)
Airbox / Screen Arrestor Fastener	6	9		M6 x 20
Manifold - to - Lower Bracket	7 13	10 18		M6 x 25 M8 x 60
Manifold - to - Cylinder Head	7	10		M6 x 30
Lower Bracket - to - Lower Crankcase	22	30		M8 x 30
Manifold Drain Fitting	11	15	Loctite 603	

Alternator Assembly Specific Fastener Torque Specifications

Component	FT. LBS.	Nm	Notes	Fastener(s)
Magnet Rotor Fastener	73	100		M12 x 90
Cable Clamp	3	4	Loctite 272	M4 x 6
Sprague Clutch	7	10	Loctite 272	M6 x 16
Stator Fasteners	7	10		M6 x 35
Stator Cover	7	10		M6 x 20 M6 x 25 M6 x 65
Regulator Fasteners	7	10		M6 x 30

ENGINE DISASSEMBLY / ASSEMBLY

Fuel Rail Specific Fastener Torque Specifications

Component	FT. LBS.	Nm	Notes	Fastener(s)
Fuel Rail Fasteners	7	10	Loctite 243	M6 x 20

Engine Management Components / Sensor Specific Fastener Torque Specifications

Component	FT. LBS.	Nm	Notes	Fastener(s)
Electronic Throttle Body	7	10		M6 x 45
Wastegate Solenoid Bracket	7	10		
Knock Sensor	14	20		M8 x 30
Temperature / Pressure Sensor (Intercooler - Air Intake Pipe)	4	5		M6 x 10
Temperature / Pressure Sensor (Intake Manifold)	5	7		M6 x 10
Crank Position / Speed Sensor	7	10		M6 x 10
Oil Pressure Switch	7	10		M10 x 1
Coolant Manifold Temp. Sensor	13	18		
Ignition Coil Fasteners	7	10		M6 x 20
Spark Plugs	20	27	Dielectric Grease	
Starter Motor Fasteners	7	10	Nyogel	M6 x 20

Balance Plate / PTO Specific Fastener Torque Specifications

Component	FT. LBS.	Nm	Notes	Fastener(s)
Balance Plate - to - Crankshaft	51	70	Loctite 577	M10 x 1 X 45

Engine Mounts Specific Fastener Torque Specifications

Component	FT. LBS.	Nm	Notes	Fastener(s)
Front Engine Mount - to - Lower Crankcase	40	55		M10 x 80
Rear Engine Mount - to - Crankcase	18	25		M8 x 30
Rear Engine mount - to - Crankcase and Lower Crankcase	40	55		M10 x 40
Intercooler Bracket - to - Front Engine Mount	7	10		M6 x 25
Intercooler Bracket - to - Crankcase	40	55		M10 x 60
Oil Storage Tank Bracket	7	10		M6 x 25

ENGINE DISASSEMBLY / ASSEMBLY

Oil Storage Tank / Oil Cooler Specific Fastener Torque Specifications

Component	FT. LBS.	Nm	Notes	Fastener(s)
Oil Separator Fastener		Hand Tighten		K80 x30
Separator Oil Return Fitting	7	10		Banjo Bolt
Oil Cooler - to - Intercooler Bracket	7	10		M6 x 20
Oil Storage Tank Rollover Valve	7	10		Banjo Bolt
Oil Storage Tank Pullover Gear Clamp	2	3		
High Pressure Oil Hose Connections (Turbocharger / Rollover Valve)	7	10		M10 x 1 Banjo Bolt

Gear Clamp Torque Specifications

8 - 16mm = 2 Nm

Over 16mm = 2.4 Nm

NOTE: Some or all clamps may be Oetiker™ clamps.

ENGINE DISASSEMBLY / ASSEMBLY

Service Tools

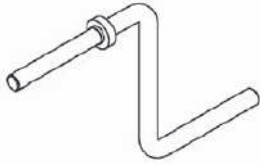

PW-46981 - REQUIRED TOOL
CRANKSHAFT HAND CRANK (BARRING TOOL)
 USED TO ROTATE CRANKSHAFT

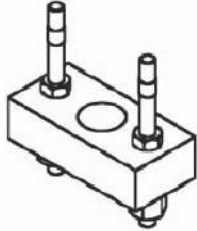

PW-46982 - REQUIRED TOOL
GEAR REMOVAL TOOL
 USED TO REMOVE BALANCE SHAFT GEAR WHEN USED WITH PW-46989 GEAR REMOVER BOLT.

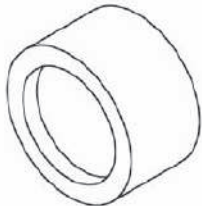

PW-46983 - REQUIRED TOOL
PISTON RING COMPRESSOR
 USED TO INSTALL PISTONS INTO ENGINE BLOCK

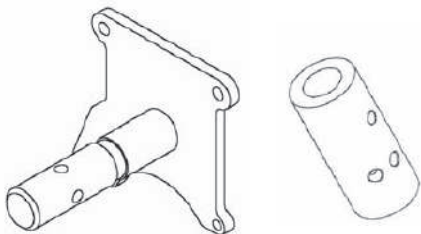

PW-46984 - REQUIRED TOOL
ENGINE STAND ADAPTER PLATE
 ATTACHES TO REAR OF ENGINE BLOCK. ALLOWS TECHNICIAN TO ROTATE ENGINE DURING DISASSEMBLY AND RE-ASSEMBLY.



PW-46985 - REQUIRED TOOL
TIMING CHAIN LINK REMOVAL / INSTALLATION TOOL
 USED IN REMOVING AND RE-INSTALLING TIMING CHAIN.

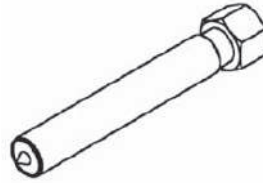

PW-46989 - REQUIRED TOOL
MAGNET ROTOR / GEAR REMOVER BOLT
 USED TO REMOVE MAGNET ROTOR AND BALANCE SHAFT GEAR WHEN USED WITH PW-46982.

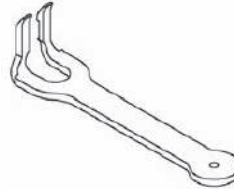

PW-46991 - REQUIRED TOOL
VALVE COMPRESSOR TOOL
 USED TO COMPRESS VALVE SPRINGS WITH ENGINE EITHER INSTALLED OR REMOVED FROM WATERCRAFT HULL.

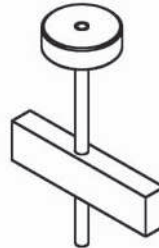

PW-47077 - REQUIRED TOOL
CAMSHAFT ALIGNMENT TOOL
 INSTALLS INTO CAMSHAFT TO LOCK INTO BDC POSITION.

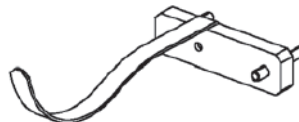

PW-47079 - REQUIRED TOOL
TIMING CHAIN INSTALLATION TOOL
 ROUTES TIMING CHAIN THROUGH ENGINE CRANKCASE DURING INSTALLATION.



PW-47108 - REQUIRED TOOL
TIMING CHAIN WEDGE AND HOOK TOOL
 USED DURING TIMING CHAIN INSTALLATION



PU-46219 - OPTIONAL TOOL
MANUAL OIL PUMP / CONTAINER
 USED TO REMOVE OIL FROM OIL TANK

ENGINE DISASSEMBLY / ASSEMBLY

OIL FILTER ASSEMBLY

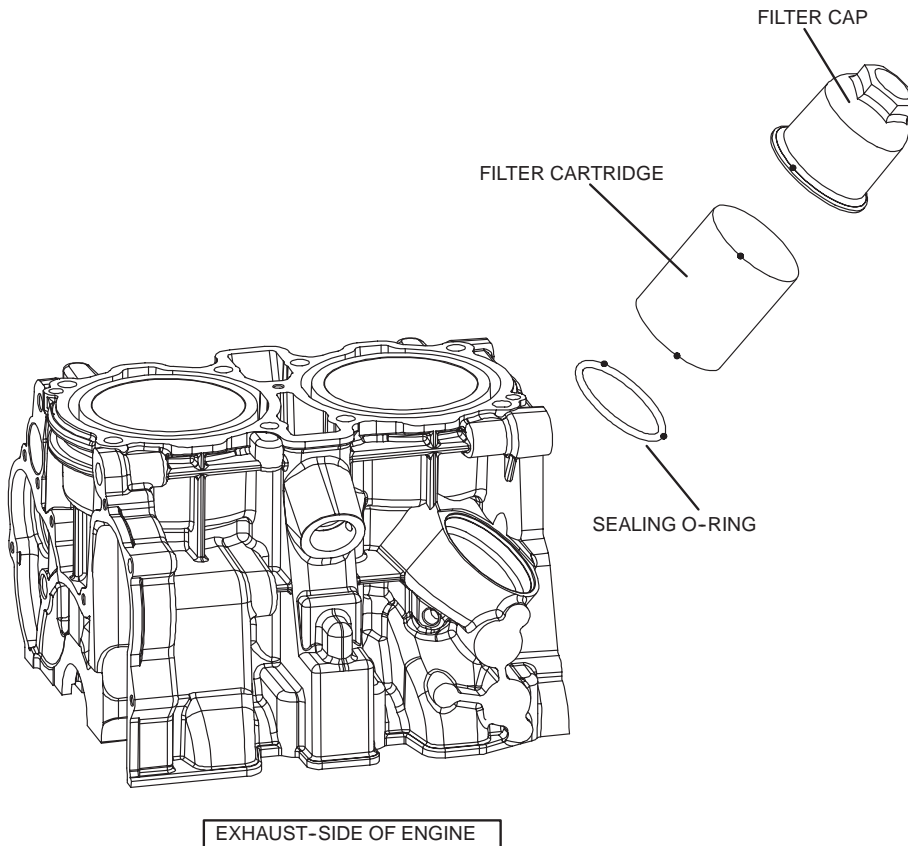

ASSEMBLY NOTES

Filter Cap Torque 18 ft.lbs. (25 Nm)

Apply a light film of engine oil to sealing o-ring and filter cap threads during installation.
OIL FILTER CHANGE INTERVAL: BREAK IN = 10 TO 12 HOURS / EVERY 25 HOURS THEREAFTER

ENGINE DISASSEMBLY / ASSEMBLY

VALVE COVER ASSEMBLY

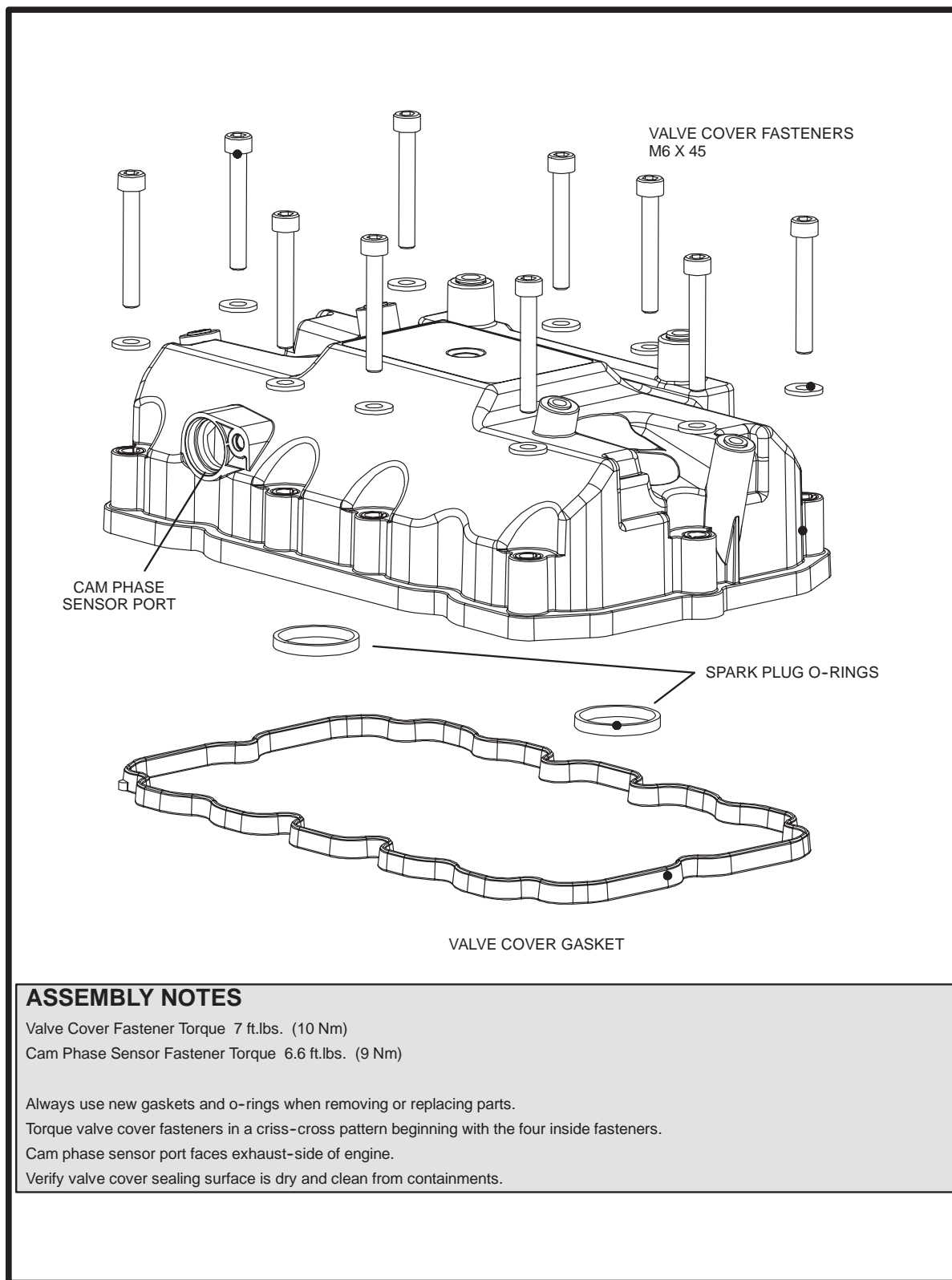

ENGINE DISASSEMBLY / ASSEMBLY

VALVE TRAIN ASSEMBLY

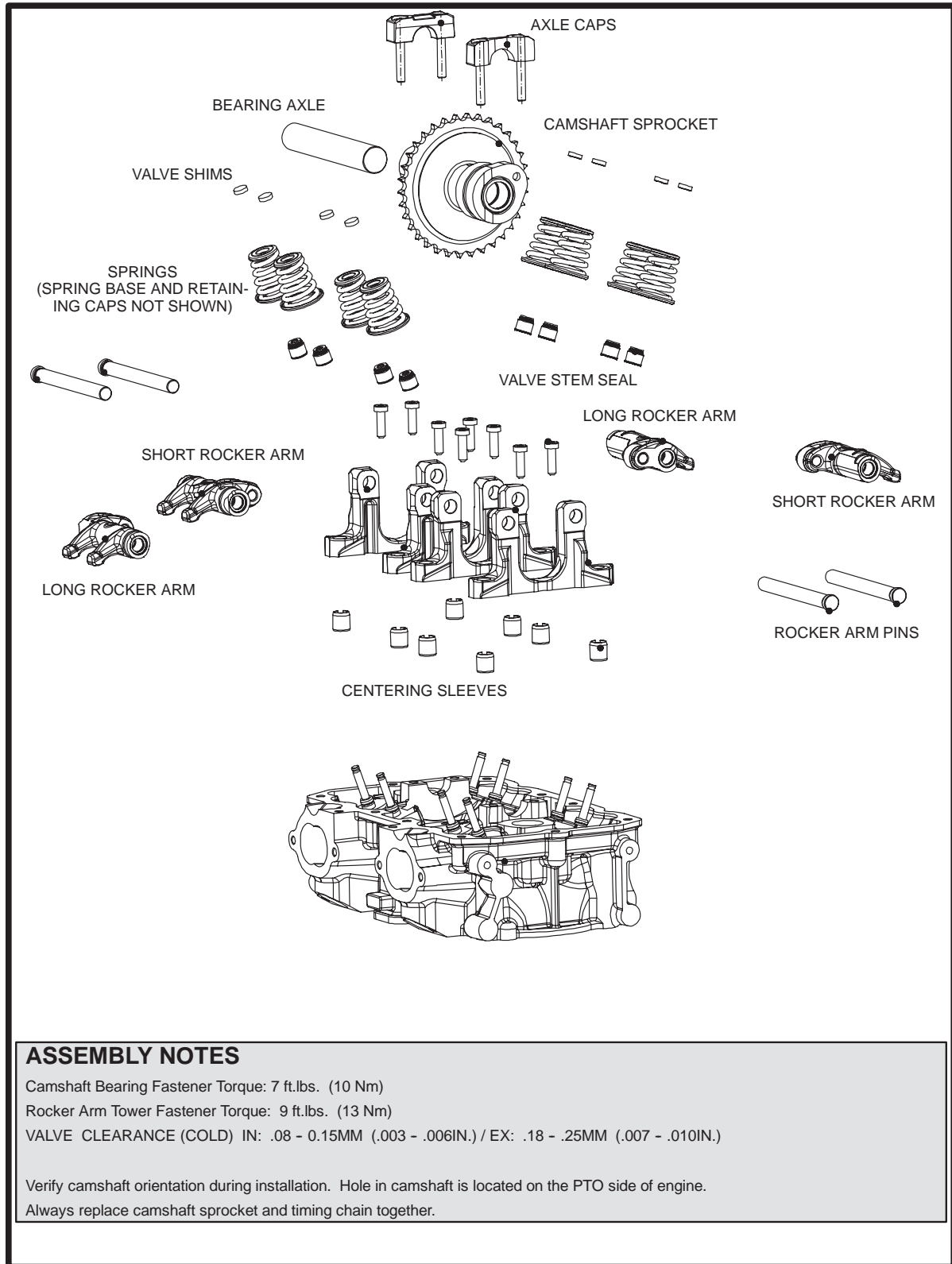

ASSEMBLY NOTES

Camshaft Bearing Fastener Torque: 7 ft.lbs. (10 Nm)

Rocker Arm Tower Fastener Torque: 9 ft.lbs. (13 Nm)

VALVE CLEARANCE (COLD) IN: .08 - 0.15MM (.003 - .006IN.) / EX: .18 - .25MM (.007 - .010IN.)

Verify camshaft orientation during installation. Hole in camshaft is located on the PTO side of engine.

Always replace camshaft sprocket and timing chain together.

ENGINE DISASSEMBLY / ASSEMBLY

DRY SUMP OIL PUMP ASSEMBLY

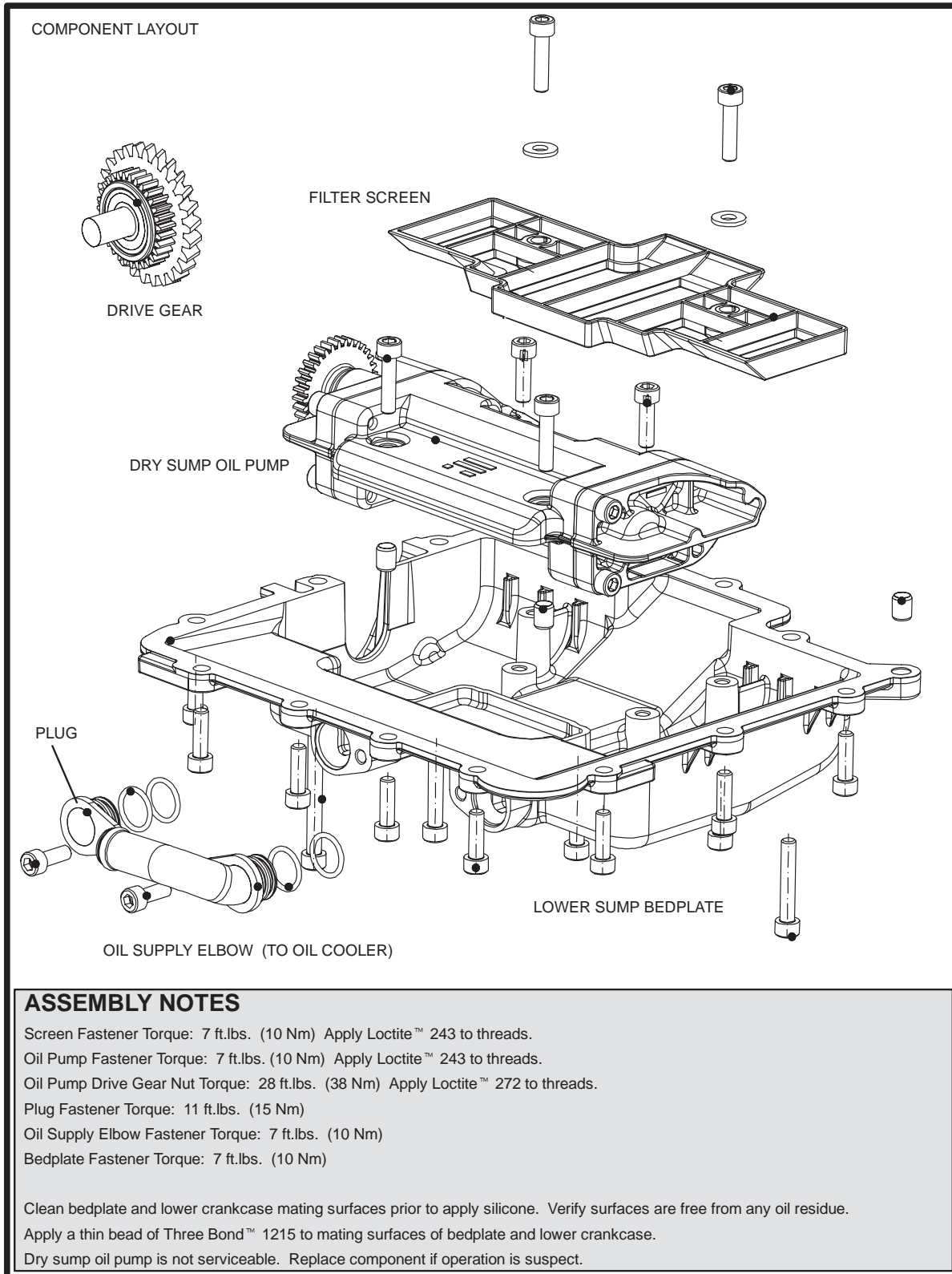

ENGINE DISASSEMBLY / ASSEMBLY

THERMOSTAT HOUSING ASSEMBLY

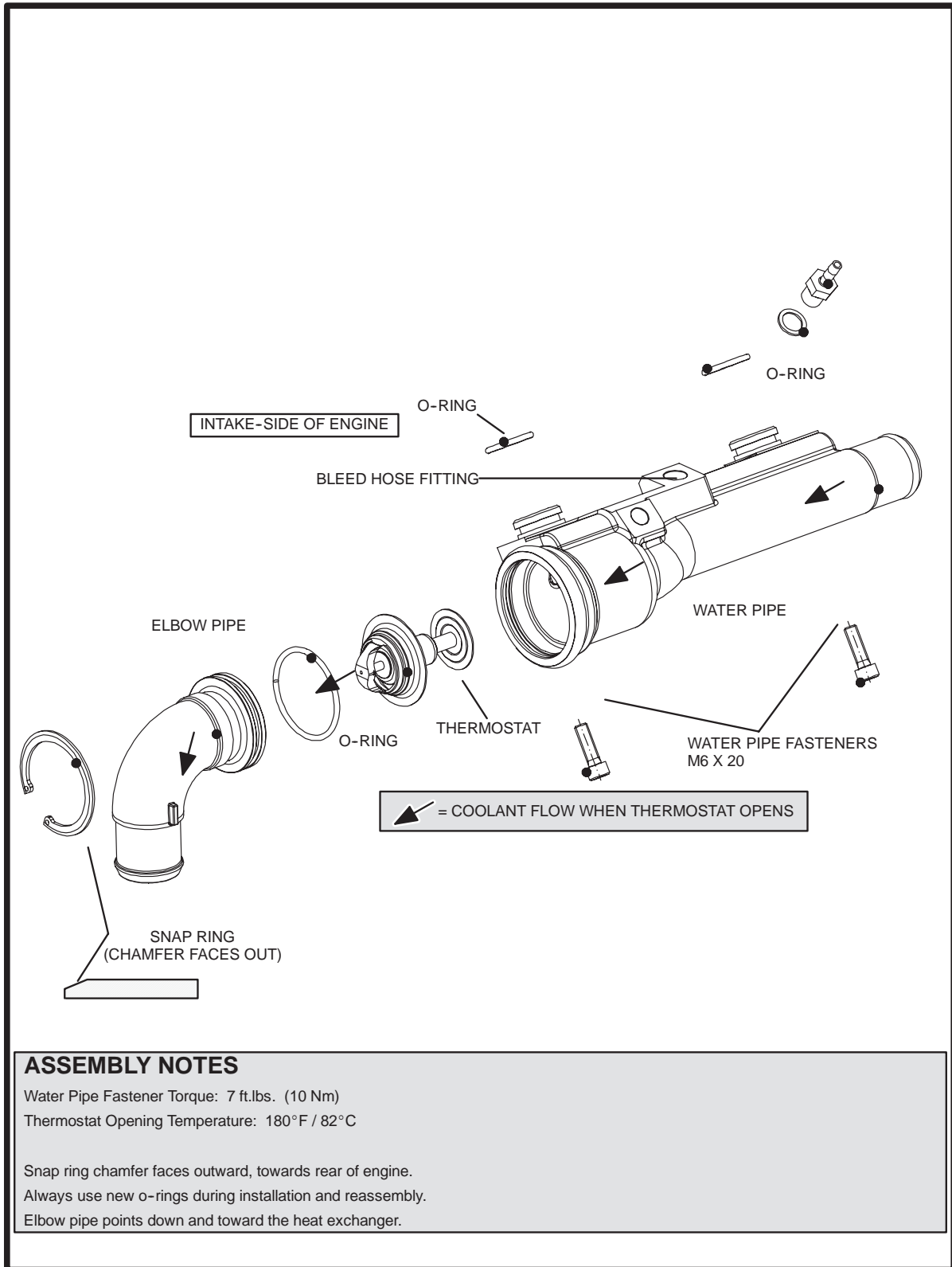

ENGINE DISASSEMBLY / ASSEMBLY

HIGH PRESSURE OIL PUMP ASSEMBLY

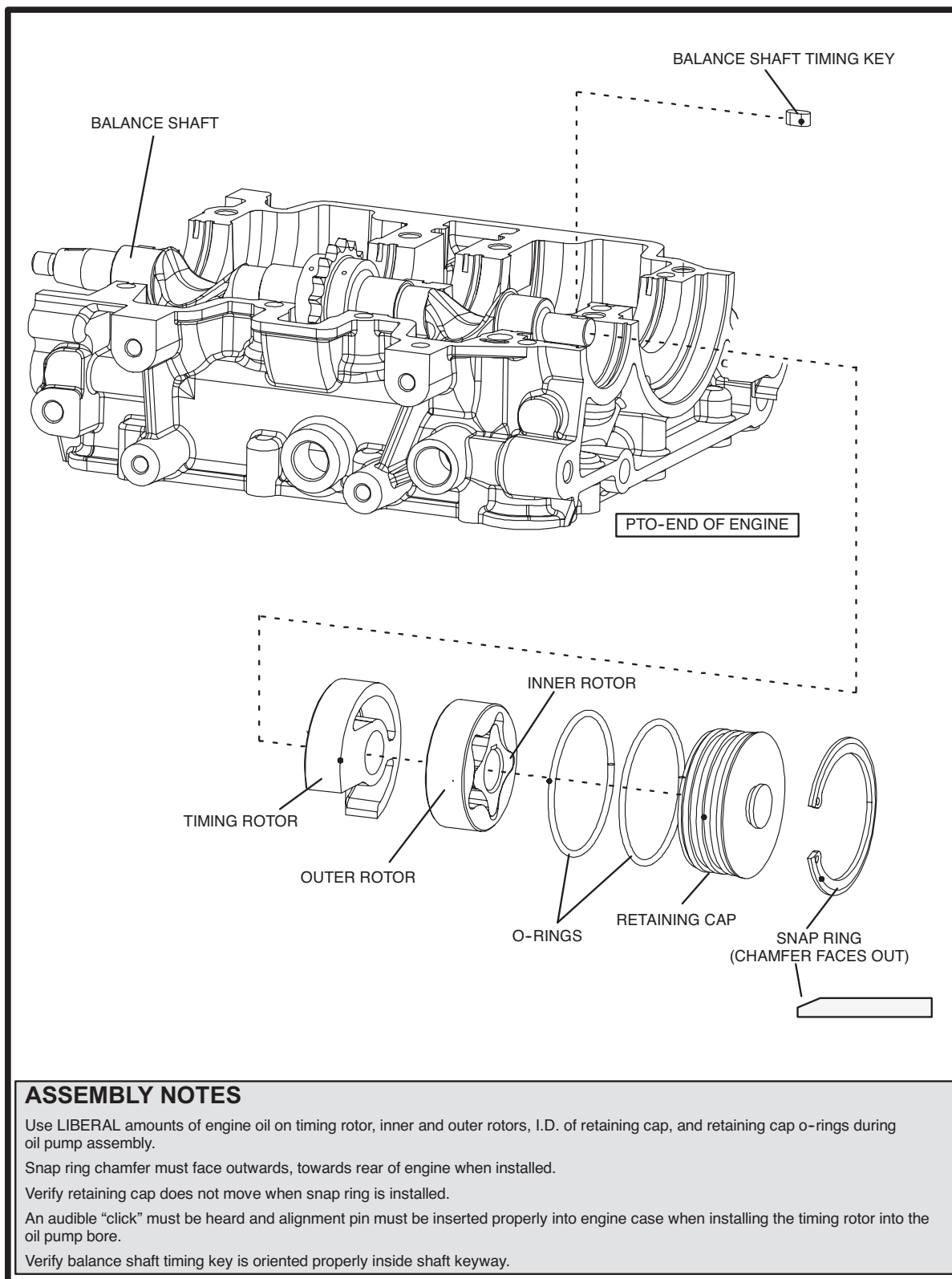

ENGINE DISASSEMBLY / ASSEMBLY

EXHAUST-SIDE CHAIN GUIDE / TENSIONER ASSEMBLY

COMPONENT LAYOUT

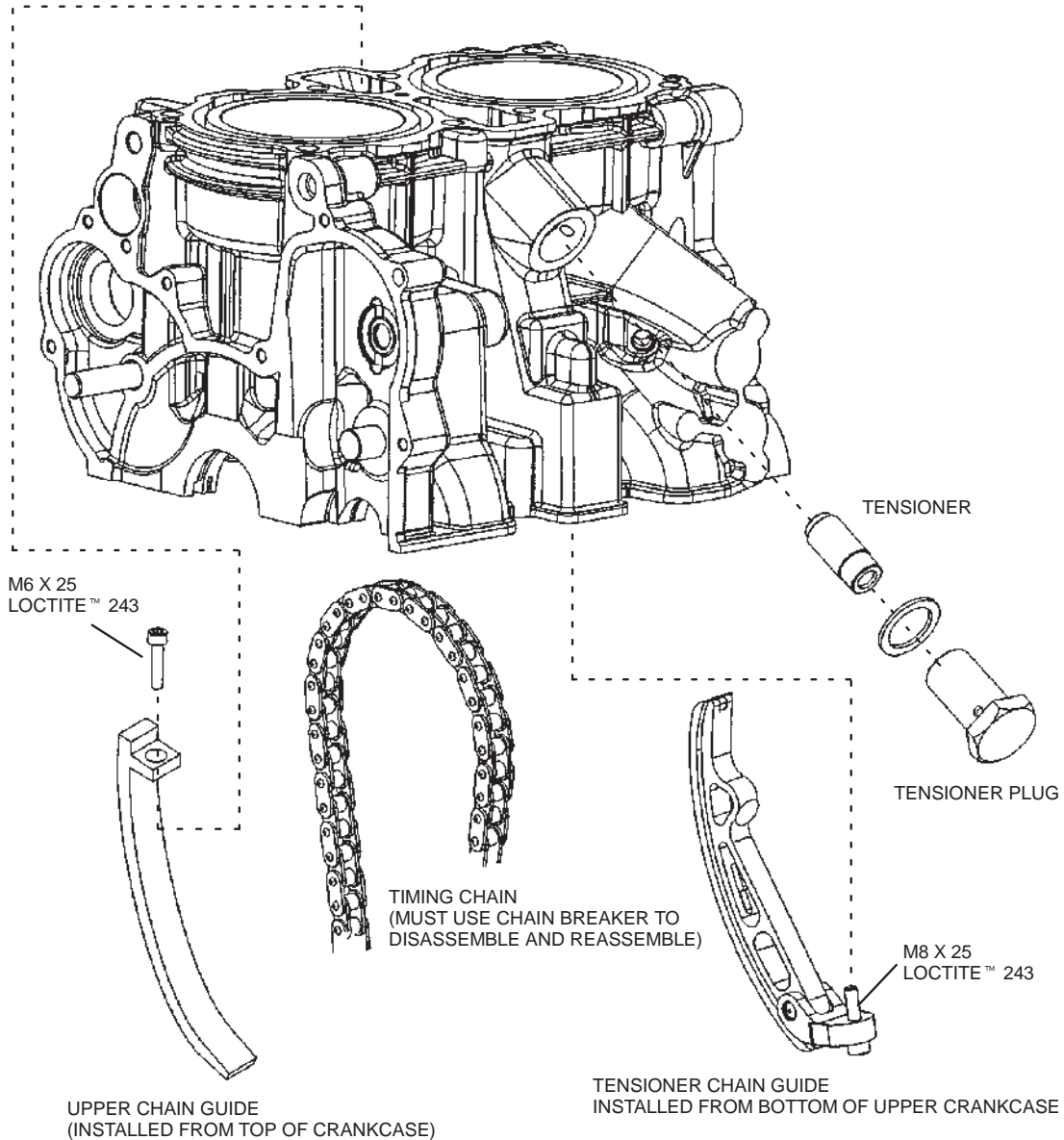

ASSEMBLY NOTES

Timing Chain Tensioner Plug Bolt Torque: 51 ft.lbs. (70Nm)

Tensioner Guide Fastener Torque: 17 ft.lbs. (24 Nm) Apply Loctite™ 243 to threads.

Replace replace tensioner rail if damaged, or unevenly worn.

Press tensioner into housing until flush with plug to set tensioner. Tensioner should remain in locked position. Activate tensioner by pushing tensioner in and past flush. Tensioner should activate and extend outwards. Replace if function is incorrect.

ENGINE DISASSEMBLY / ASSEMBLY

ENGINE CASE / CYLINDER HEAD ASSEMBLY

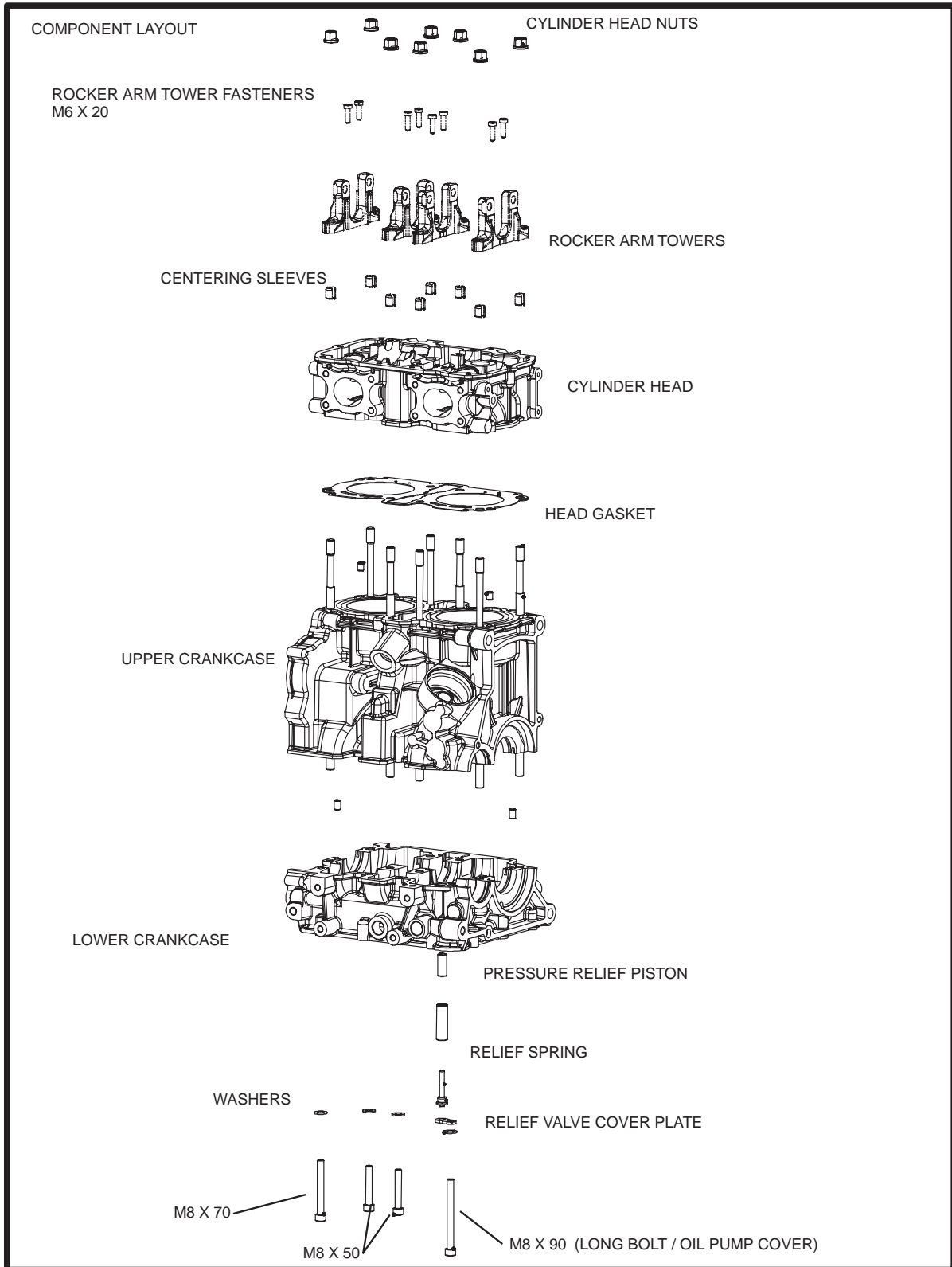

ENGINE DISASSEMBLY / ASSEMBLY

ENGINE CASE / CYLINDER HEAD ASSEMBLY - CONTINUED

ASSEMBLY NOTES

CYLINDER HEAD - TO - CRANKCASE TORQUE SEQUENCE SPECIFICATIONS

Apply engine oil to bolt threads.

1st STEP: Torque cylinder head nuts in sequence.
15 ft.lbs. (20 Nm)
Torque crankcase fasteners in sequence.
12 ft.lbs. (16 Nm)

2nd STEP: Torque cylinder head nuts in sequence
30 ft.lbs. (40 Nm)

3rd STEP: Torque cylinder head nuts in sequence.
180°
Torque crankcase fasteners in sequence.
18 ft.lbs. (24 - 25 Nm)

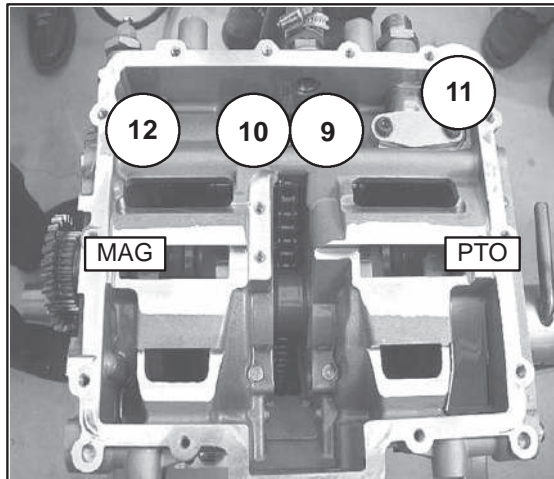
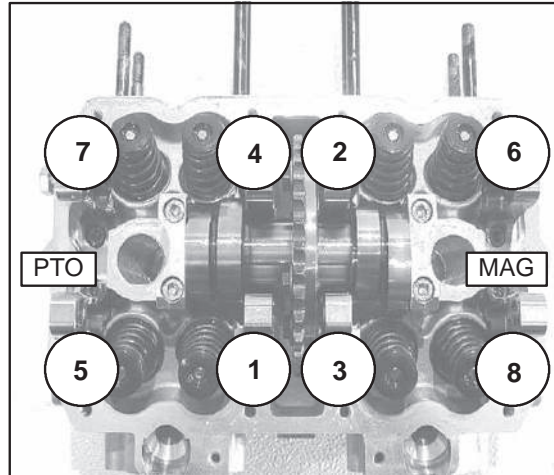

ENGINE DISASSEMBLY / ASSEMBLY

PISTON ASSEMBLY

COMPONENT LAYOUT

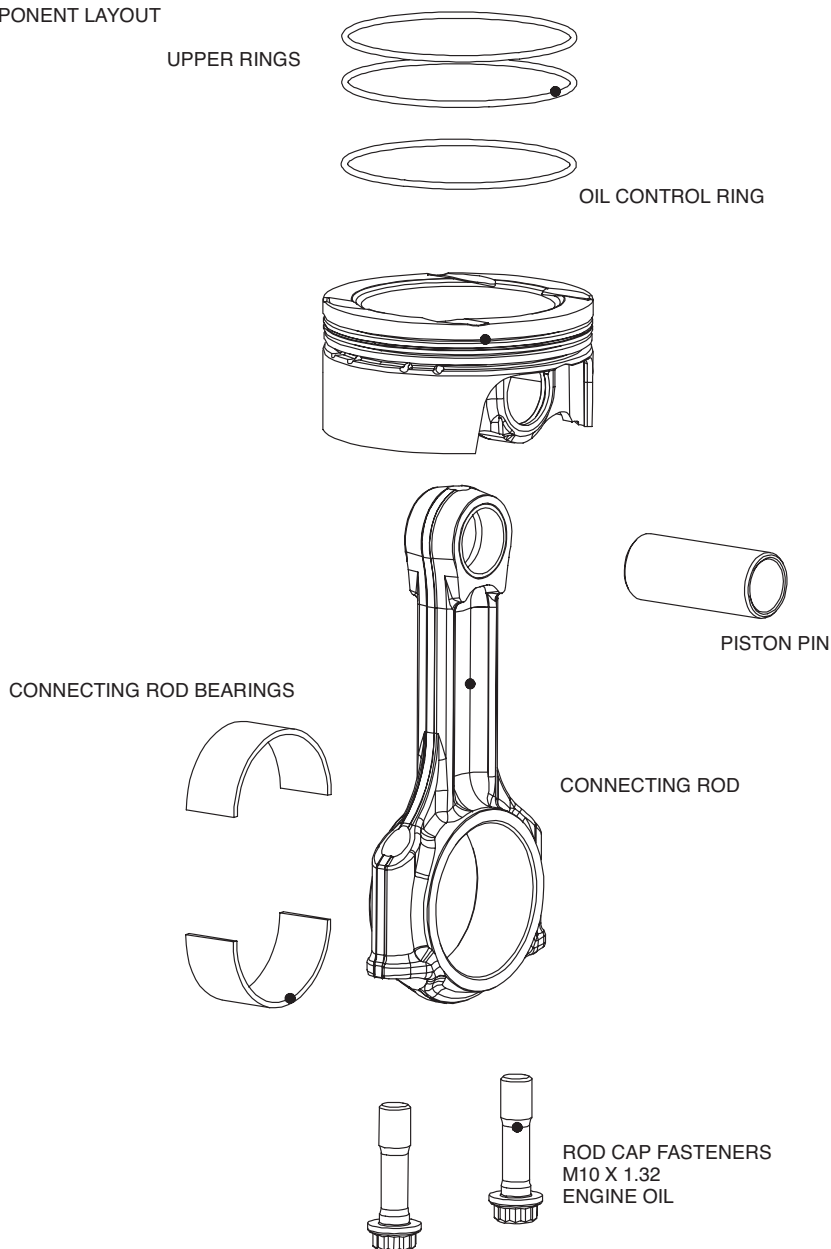

ASSEMBLY NOTES

AVAILABLE BEARINGS: 1. RED .0783 - .0785IN. (1.990 - 1.995mm) 2. YELLOW .0785 - .0787IN. (1.995 - 2.000mm)
3. BLUE .0787 - .0789IN. (2.000 - 2.005mm) 4. GREEN .0789 - .0791IN. (2.005 - 2.010mm)
5. BROWN .0791 - .0793IN. (2.010 - 2.015mm)

Rod Cap Fastener Torque: 1st Step: 7 ft.lbs. (10 Nm)
2nd Step: 14 ft.lbs. (20 Nm)
3rd Step: Turn 90°

APPLY ENGINE OIL TO FASTENER THREADS PRIOR TO INSTALLATION.

Connecting rod caps feature a "cracked" mating surface. Cap must be marked during removal and installed correctly.

ENGINE DISASSEMBLY / ASSEMBLY

VALVE ASSEMBLIES

COMPONENT LAYOUT

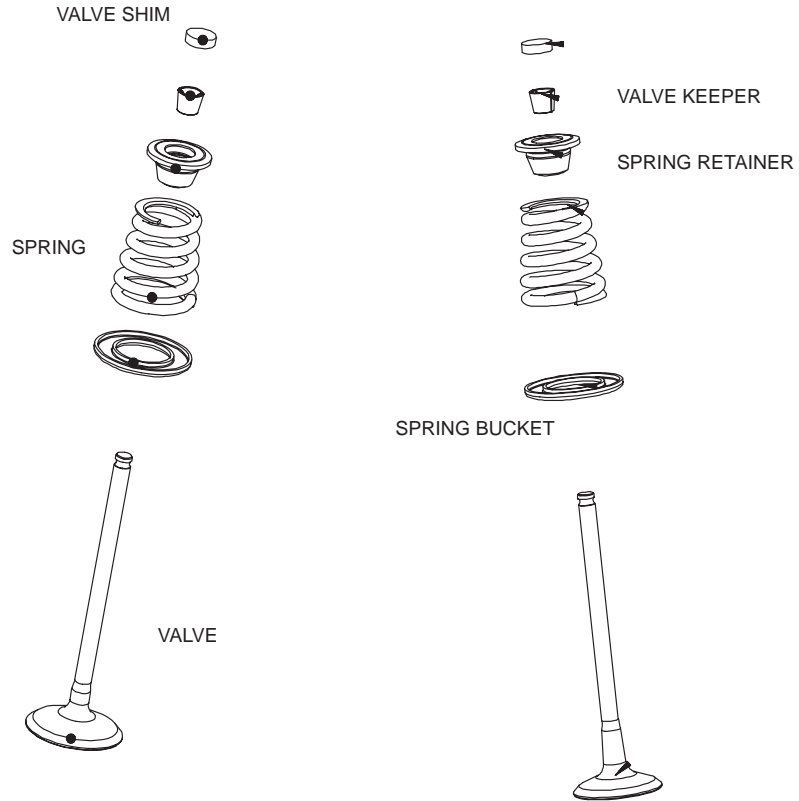

ENGINE DISASSEMBLY / ASSEMBLY

BALANCE PLATE / PTO ASSEMBLY

COMPONENT LAYOUT

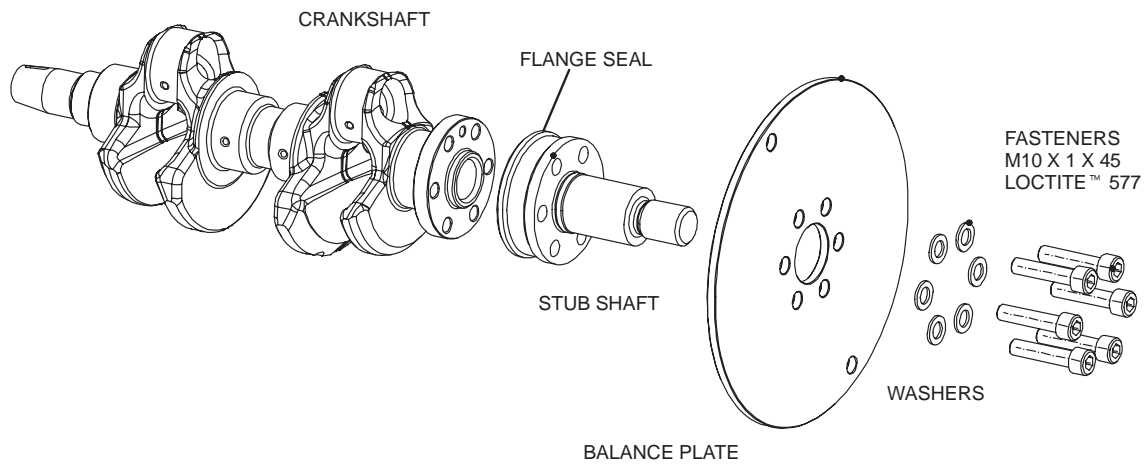

ASSEMBLY NOTES

Balance Plate Fastener Torque: 51 ft.lbs. (70 Nm) Apply Loctite™ 577 to threads.

ENGINE DISASSEMBLY / ASSEMBLY

CRANKSHAFT / COUNTER BALANCER ASSEMBLIES

COMPONENT LAYOUT

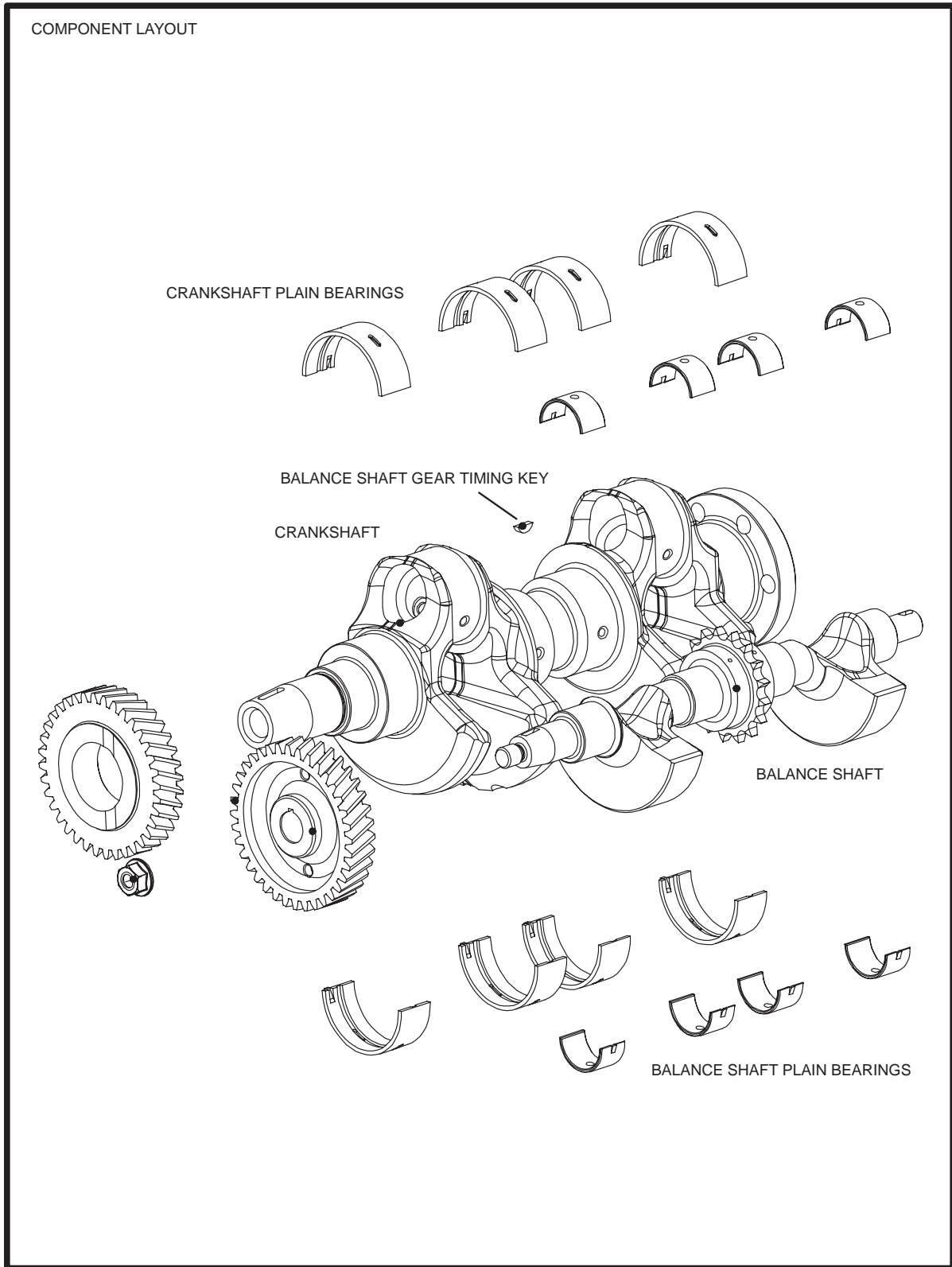

ENGINE DISASSEMBLY / ASSEMBLY

Engine Disassembly Process

1. Remove valve cover from engine. Discard gaskets. (*Photo A*)

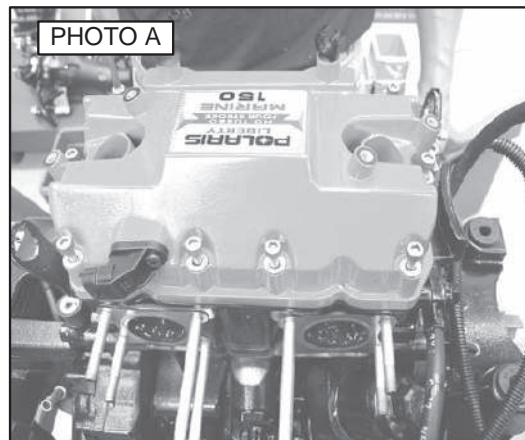

2. Remove the coolant outlet manifold, oil filter cover, and electric starter motor from engine case. (*Photo B*)

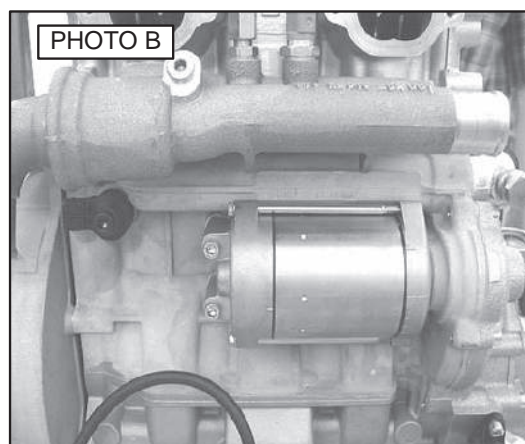

3. Remove the two high pressure oil feed hose banjo bolts from the cylinder head exhaust-side rear mounting location. (*Photo C*)

NOTE: The two high pressure oil feed hoses supply oil to the turbocharger bearing house, and oil supply shutoff valve located on the top of the oil supply tank.

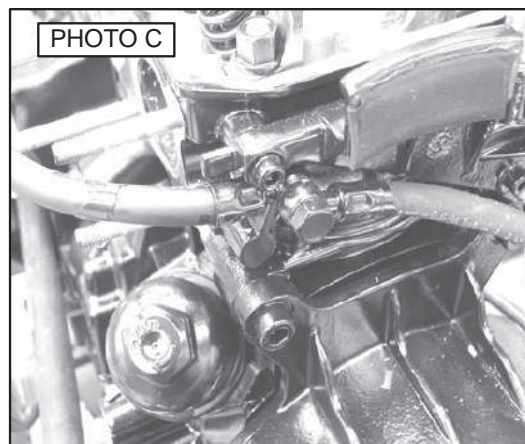

ENGINE DISASSEMBLY / ASSEMBLY

Engine Disassembly Process

4. Remove the stator cover from the flywheel housing. (Photo D)

NOTE: The stator is attached to the inside of the cover. Note the two alignment dowels as circled in photo.

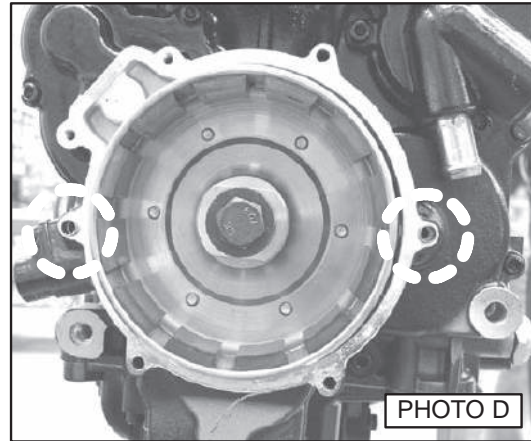

5. Photo of stator inside of cover. (Photo E)

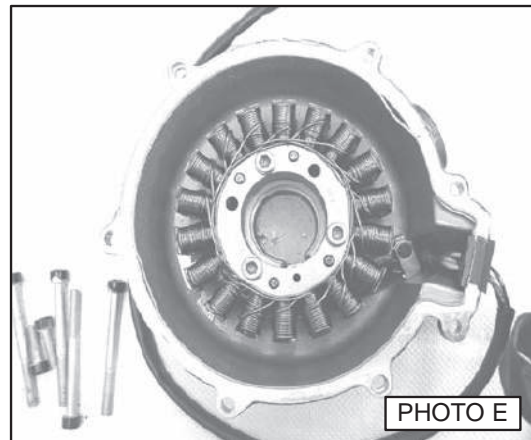

6. Remove the water pump cover and impeller. (Photo F)

NOTE: The impeller can be removed by turning the nut counter-clockwise. Hold the flywheel stationary while removing the impeller.

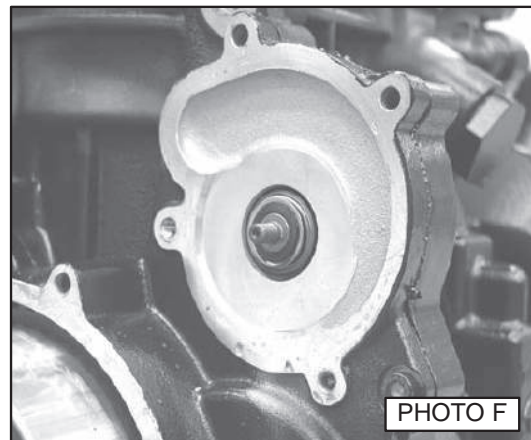

ENGINE DISASSEMBLY / ASSEMBLY

Engine Disassembly Process

7. Remove the front engine gear cover. (*Photo G*)

NOTE: Place drain pan underneath cover to catch oil.

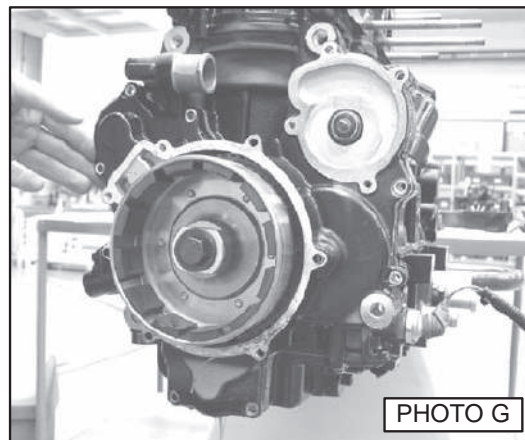

8. Install two of the PTO coupler bolts into the PTO-end of the crankshaft. Have an assistant place a pry bar across these two bolts to prevent the crankshaft from rotating. (*Photo H*)

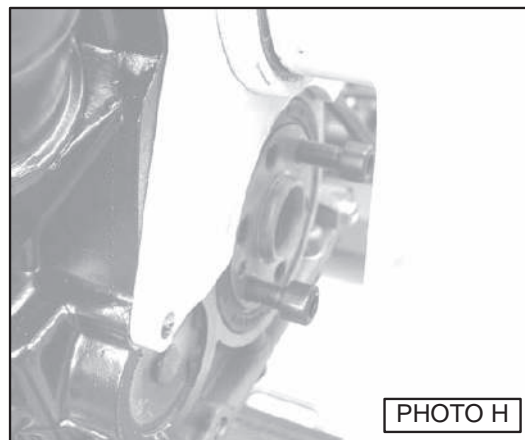

9. Remove the flywheel bolt and washer from the front of the engine. Install flywheel puller bolt into flywheel PN-PW-46989. Carefully tighten puller bolt until flywheel comes off of crankshaft nose. (*Photo I*)

10. Remove the flywheel timing key and roller bearings from crankshaft.

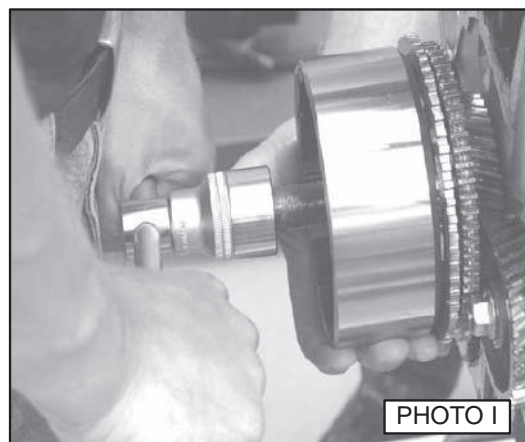

ENGINE DISASSEMBLY / ASSEMBLY

Engine Disassembly Process

11. Photo of front of engine. Remove the starter motor drive gear assembly (A) and oil pump drive gear (B). (Photo J)

NOTE: The balance shaft gear (C) is removed by using tool: PN PW-46982 and PW-46989. Gear removal is not required. Only remove if damaged or replacement of balance shaft is required.

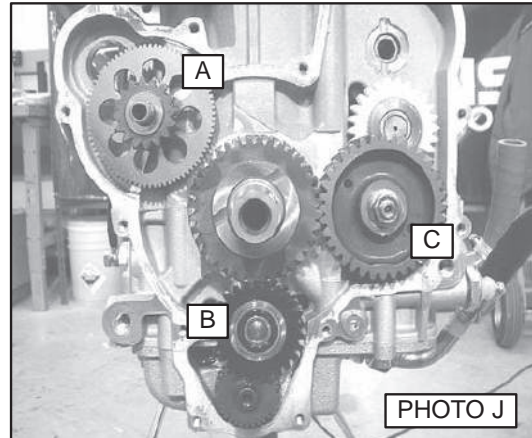

12. Remove lock pin and rotate engine 180°. Remove the sump cover. (Photo K)

NOTE: The sump oil pump is attached to the inside of the sump cover.

13. Install crankshaft hand crank, PN PW-46981 into nose of crankshaft. Tighten lock nut against crankshaft.

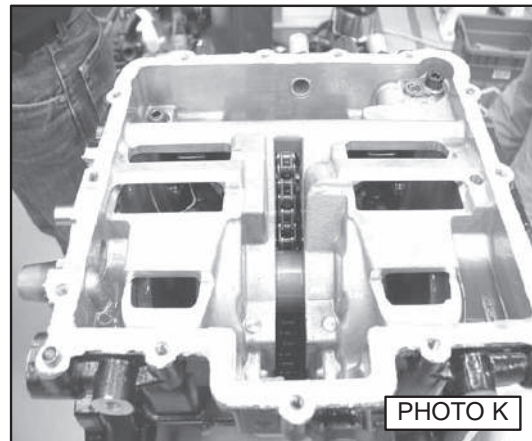

14. The high pressure oil pump is located on the PTO side of the engine. It is connected to the balance shaft. Remove the snap ring from the high pressure oil pump cover. Carefully extract the cap, outer and inner rotors, timing key and timing rotor from engine. (Illustration 1)

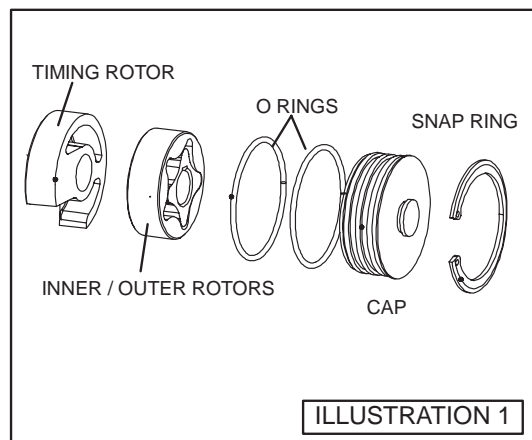

ENGINE DISASSEMBLY / ASSEMBLY

Engine Disassembly Process

15. Rotate the engine assembly 180° so that the valve train is up. Using the hand crank, crank the engine until the PTO piston is at TDC on the compression stroke. BOTH PTO ROCKER ARMS WILL BE LOOSE.
16. Using a flat-head screwdriver, push the rocker arm pins out enough to expose the detents on the pins. Remove the pins from the cylinder head. (Photo L)
17. Rotate the engine 360° counter-clockwise. Perform steps 15 and 16 on the MAG cylinder valve train.

NOTE: A piston is at TDC on the compression stroke when the piston is up and there is axial free-play in each of the rocker arms.

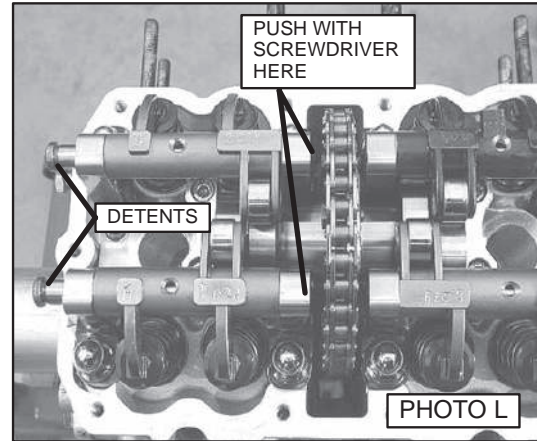

18. Place rocker arm assemblies and rocker arm pins on a clean towel or piece of paper. Identify each part for use during assembly. (Photo M)

NOTE: The MAG, exhaust-side rocker arm features a cam phase sensor pickup nose as circled in photo M.

19. Remove the valve shims. Place valve shims with corresponding rocker arm and location.
20. Remove the chain tensioner bolt located next to the oil filter location.

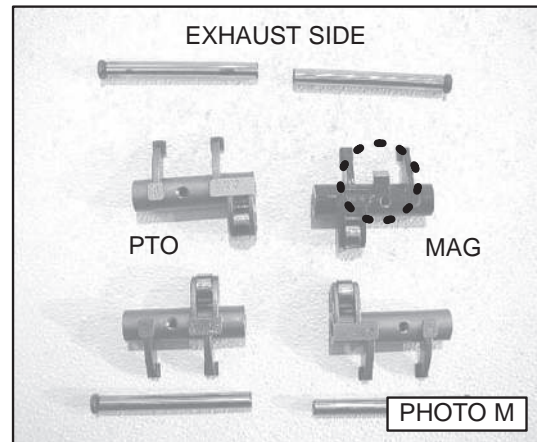

21. Attach the chain breaker tool, PN-PW-46985.
22. Using the chain breaker tool, carefully press the pin out of the link plate. Once outer plate is loose, disconnect the tool and remove the last pin.
23. Remove the two pins from the chain, but do not pull the chain away from the cam sprocket.

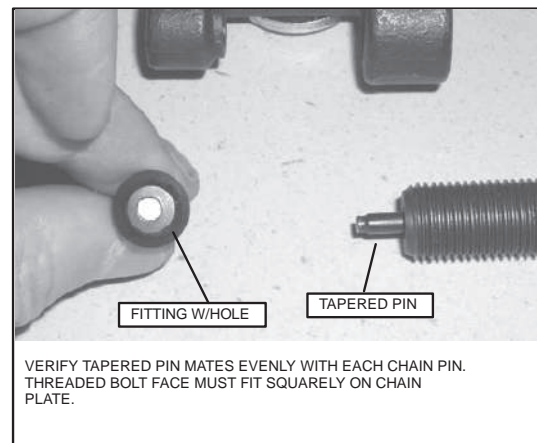

ENGINE DISASSEMBLY / ASSEMBLY

Engine Disassembly Process

24. Rotate the engine assembly 180° so that the valve train is down, facing the floor. Using the hand crank, crank the timing chain out of the engine.

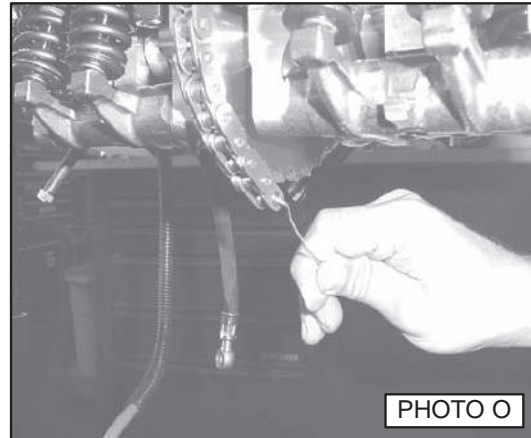

25. With the timing chain removed from the engine, the crankcase can be split in two. To begin, loosen and remove the four case bolts located in the oil sump gallery. (*Photo O*)

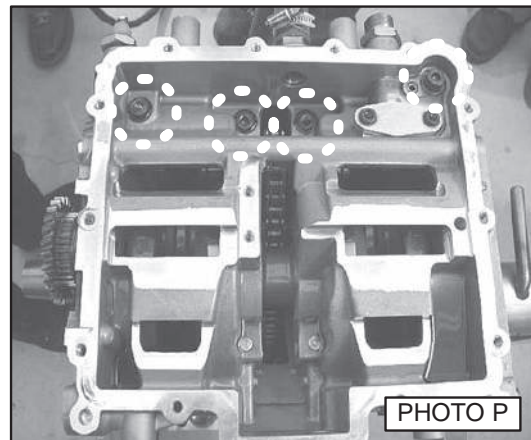

26. The lower case bolt located on the PTO side also holds the oil pump relief piston cover in place. (*Photo P*)
27. Once the plate is removed, use a magnet to remove the spring and piston from inside the bore.

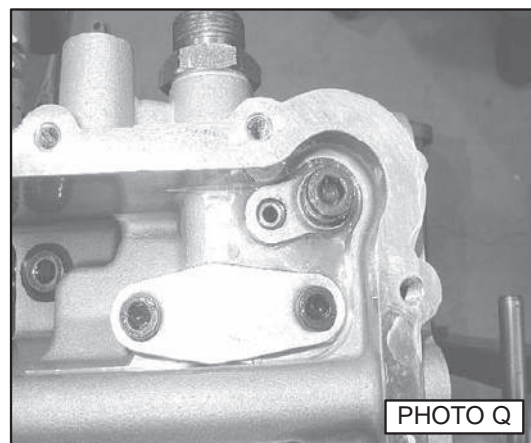

ENGINE DISASSEMBLY / ASSEMBLY

Engine Disassembly Process

28. Rotate the engine assembly 180° so that the valve train is up. Evenly loosen and remove the cylinder head nuts. (*Photo R*)
29. Carefully pull the cylinder head assembly up and off of the crankcase.

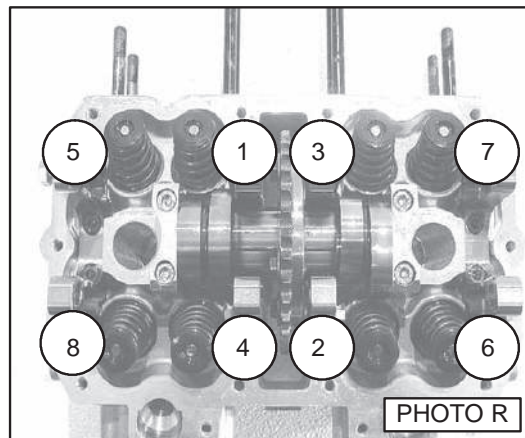

30. Remove the chain guide fastener and chain guide. (*Photo S*)

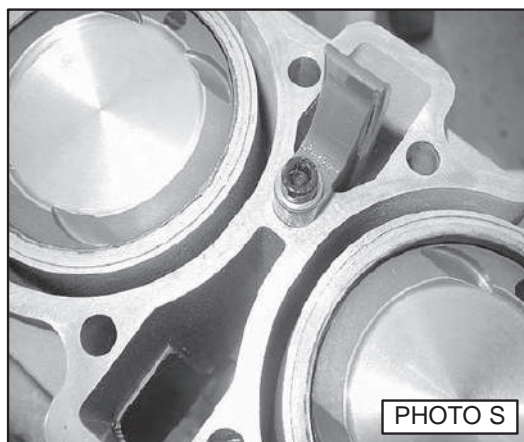

31. Rotate the engine assembly 180°. Remove the tensioner chain guide from the crankcase.
32. Using a soft-faced hammer, carefully tap the lower section of the crankcase loose from upper crankcase. Once loose, pull the lower crankcase up and away from the upper case. (*Photo T*)

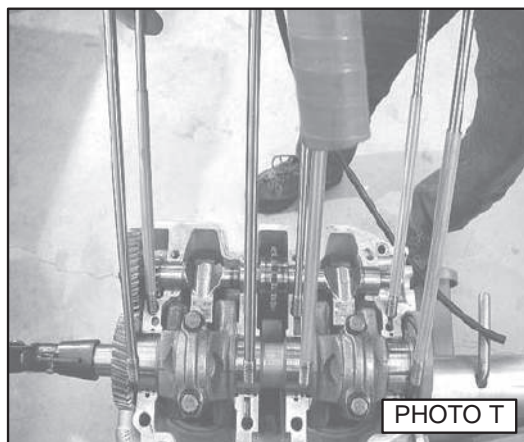

ENGINE DISASSEMBLY / ASSEMBLY

Engine Disassembly Process

33. Remove the balance shaft from the crankcase. Remove the PTO crankshaft case seal and discard. Remove the piston lower rod cap bolts. (*Photo R*)
34. Carefully push each piston through and out of the crankcase. Match each rod cap with its corresponding connecting rod. (*Photo U*)

NOTE: The connecting rod caps are “cracked” during manufacture creating a unique mating surface between the connecting rod and cap. Always verify that the lower cap matches the connecting rod.

35. Always keep the connecting rod plain bearings, rod caps, and bolts with the piston assembly the engine was manufactured with.

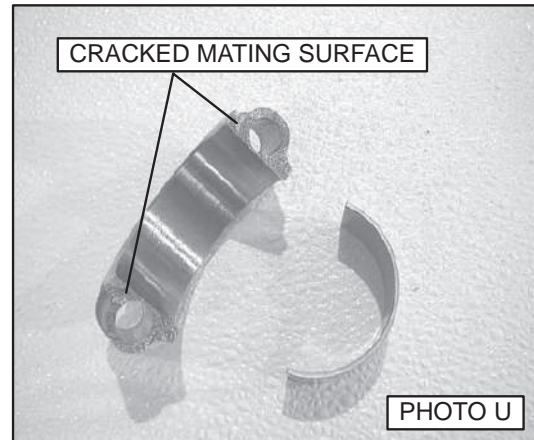

36. Remove the crankshaft assembly from the crankcase. Remove each crankshaft plain bearing from both crankcase halves and place with its original crankshaft journal.

NOTE: Always mark the bearings for identification during assembly and oil clearance measuring procedures.

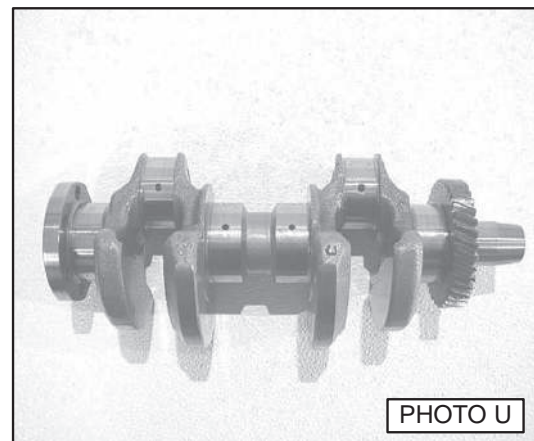

ENGINE DISASSEMBLY / ASSEMBLY

Engine Inspection Procedures

Valve Inspection

NOTE: Valves cannot be replaced. If valve face is burned or excessively worn, replace valve.

Measure diameter of valve.

- Out of specification: Replace

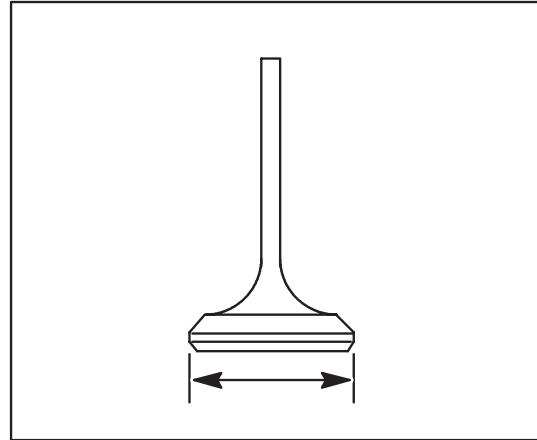

Measure valve face width.

- Out of specification: Replace valve

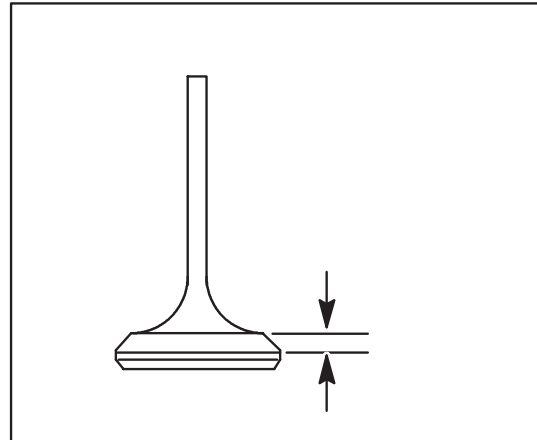

Measure valve seat contact width.

1. Apply light coating of Prussian Blue or similar dye compound to valve face.
2. Install valve into valve guide.
3. Tap valve several times to make a clear impression on the valve face. Do not rotate valve.
4. Remove valve and measure valve seat width.
 - Out of specification: Recondition or replace cylinder head.

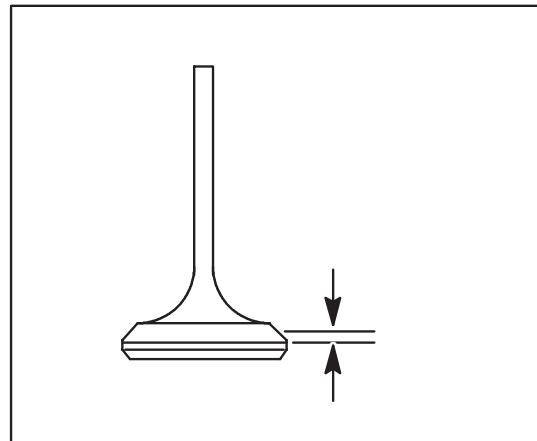

Engine Inspection Procedures

Valve Inspection

Measure valve margin thickness.

- Out of specification: Replace valve

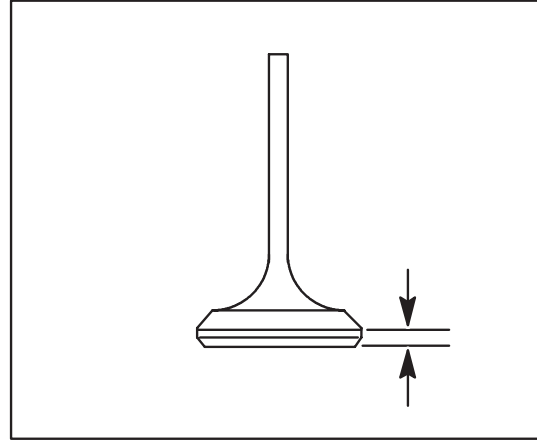

Measure valve stem diameter.

- Out of specification: Replace valve

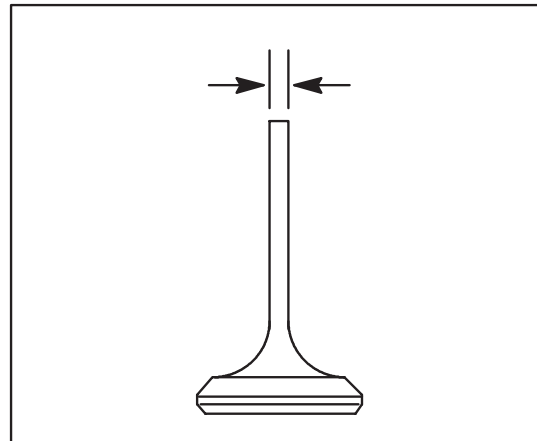

Measure valve guide inside diameter.

- Out of specification: Replace valve guide

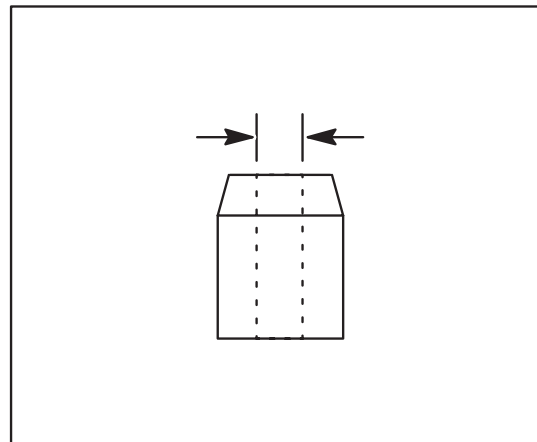

ENGINE DISASSEMBLY / ASSEMBLY

Engine Inspection Procedures

Valve Inspection

Measure valve stem runout.

- Out of specification: Replace valve

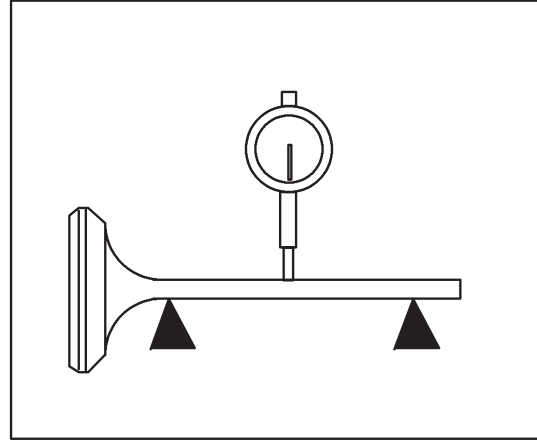

Measure valve spring free and installed length.

- Out of specification: Replace spring



Cylinder Head Inspection

Measure cylinder head warpage.

- Out of specification: Replace cylinder head

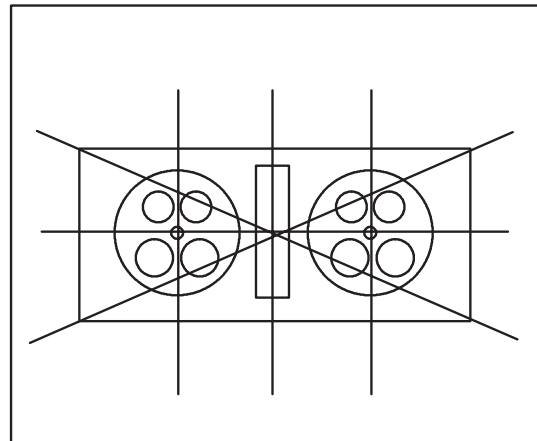

Engine Inspection Procedures

Cylinder Block Inspection

Measure cylinder bore size.

- Out of specification: Replace cylinder block

NOTE: Cylinders are plated with NiCaSil.

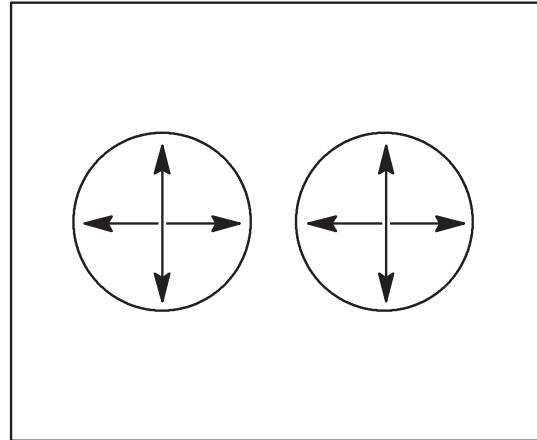

Measure cylinder for taper and out-of-round limits.

1. BORE = Maximum diameter of Da - Df.
 2. TAPER = Maximum of Da - De and Db - Df.
 3. Out-of-Round = Maximum of Da - Db and De - Df.
- Out of specification: Replace cylinder block

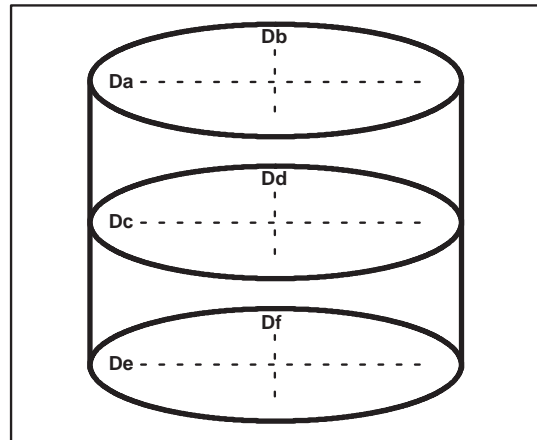

Camshaft Inspection

Measure camshaft width.

- Out of specification: Replace camshaft

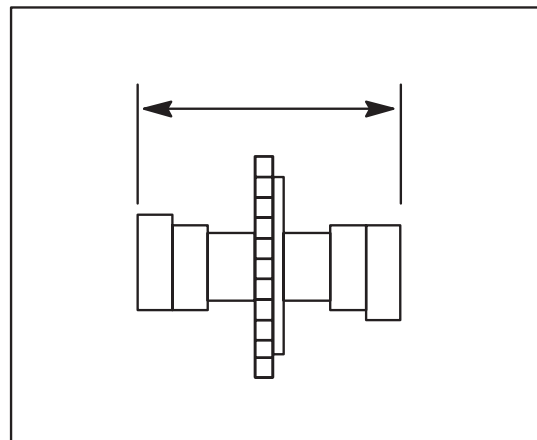

ENGINE DISASSEMBLY / ASSEMBLY

Engine Inspection Procedures

Camshaft Inspection

Measure cam lobe height.

- Out of specification: Replace camshaft

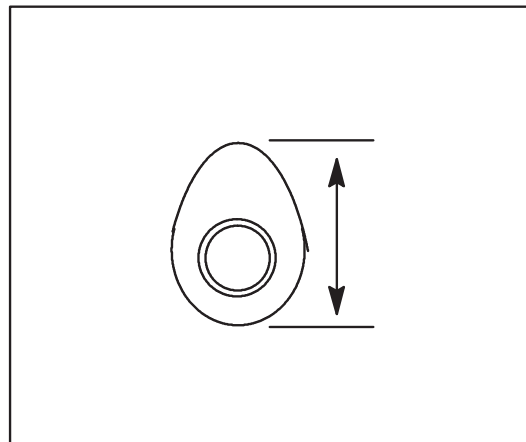

Measure camshaft runout.

- Out of specification: Replace camshaft

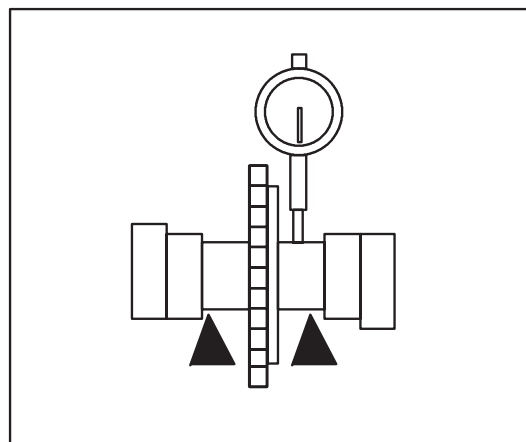

Measure camshaft bearing hole inside diameter.

- Out of specification: Replace camshaft

NOTE: Bearings must be removed to measure I.D.

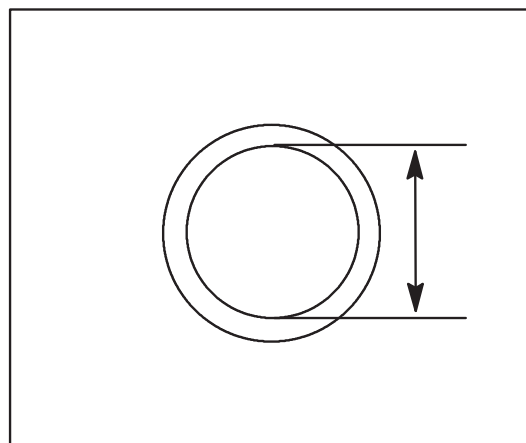

ENGINE DISASSEMBLY / ASSEMBLY

Engine Inspection Procedures

Camshaft Inspection

Measure camshaft axle outside diameter.

- Out of specification: Replace axle

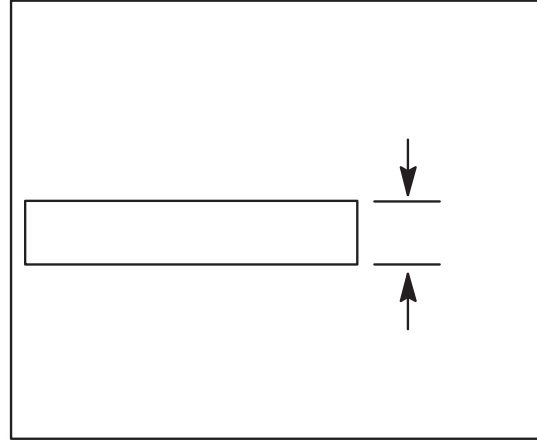

Measure camshaft axle clamp inside diameter.

- Out of specification: Replace cylinder head

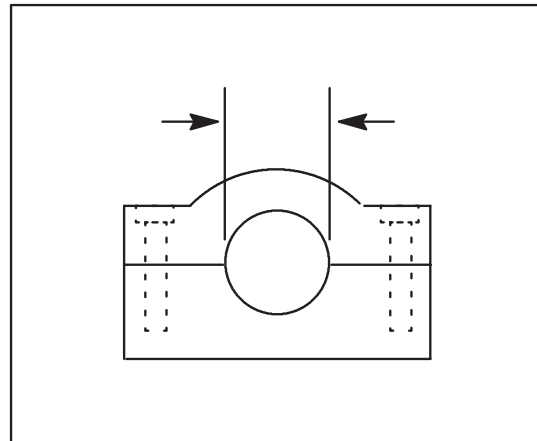

Rocker Arm Inspection

Measure rocker arm axial play.

- Out of specification: Replace rocker arm

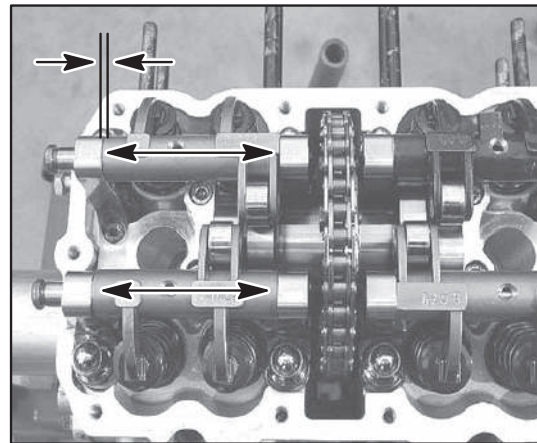

ENGINE DISASSEMBLY / ASSEMBLY

Engine Inspection Procedures

Rocker Arm Inspection

Measure rocker arm shaft outside diameter.

- Out of specification: Replace rocker arm shaft

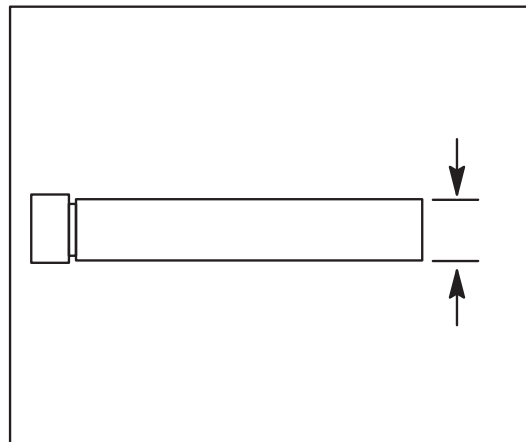

Measure rocker arm post bore inside diameter.

- Out of specification: Replace rocker arm post

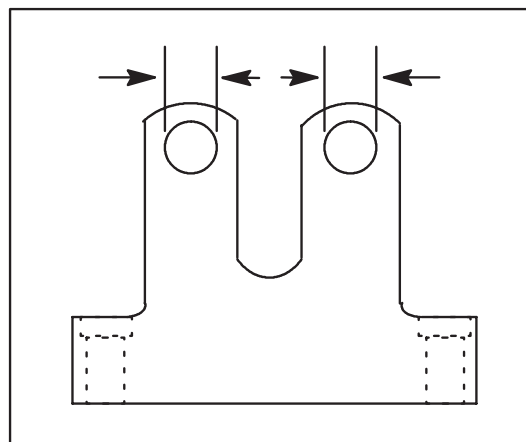

Crankshaft Inspection

Measure crankshaft deflection.

- Out of specification: Replace crankshaft

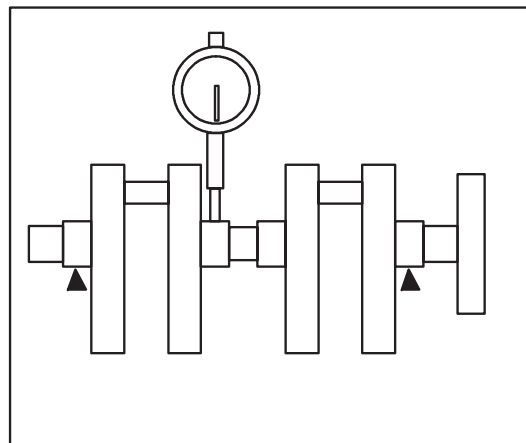

ENGINE DISASSEMBLY / ASSEMBLY

Engine Inspection Procedures

Crankshaft Inspection

NOTE: Do not move crankshaft until measurement process is completed. Do not place on oil holes.

Measure crankshaft main bearing clearance.

1. Place upper journal bearings into upper casehalf.
2. Install crankshaft. Place a piece of Plastigauge® across the journal surface. Install lower crankcase half with journal bearings installed.
3. Loosely install lower crankcase bolts, turn engine up on stand.
4. Install old cylinder head gasket, cylinder, and the cylinder head nuts. Torque nuts and bolts to specified torque and tightening sequence.
5. Carefully remove components and measure each compressed piece of Plastigauge®.
6. Reference bearing replacement guide if bearing oil clearance is out of specification.
 - Out of specification: Replace main bearings, crankcase, or crankshaft.

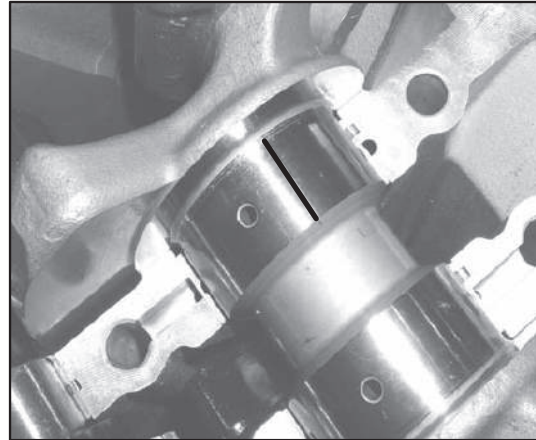

Crankshaft Main Bearing Replacement Guide

Replacement of the crankshaft main bearings is required when the bearing oil clearance is out of specification. Use this guide to select new bearings.

NOTE: Bearing color code is imprinted on the side of each bearing.

SPECIFIED OIL CLEARANCE: .0011" - .0015" (.03mm - .04mm)

MEASURED OIL CLEARANCE: _____

ORIGINAL INSTALLED BEARING COLOR / THICKNESS: _____

REPLACEMENT BEARING THICKNESS

RED	.0677" - .0679" (1.721 - 1.726mm)
YELLOW	.0679" - .0681" (1.726 - 1.731mm)
BLUE	.0681" - .0683" (1.731 - 1.736mm)
GREEN	.0683" - .0685" (1.736 - 1.741mm)
BROWN	.0685" - .0687" (1.747 - 1.746mm)

If the measured clearance is within specification, replace with new bearings with the same color code.

If the oil clearance is outside of specification, install the BLUE color-coded bearings and re-measure oil clearance. If the measured clearance is too small, install either a RED or YELLOW bearing. If the measured clearance is too large, install either a BROWN or GREEN bearing.

If the used bearings reveal an oil clearance of .04 and .05mm, install new bearings with the same color code.

ENGINE DISASSEMBLY / ASSEMBLY

Connecting Rod Inspection

Measure big end oil clearance.

NOTE: Do not move crankshaft or connecting rods until measurement process is completed.

1. Remove lower connecting rod caps.
2. Place a piece of Plastigauge® across the journal surface. Install lower rod caps with journal bearings installed.
3. Torque rod bolts to specified torque.
4. Remove caps and measure each compressed piece of Plastigauge®.
5. Reference bearing replacement guide if bearing oil clearance is out of specification.
 - Out of specification: Replace connecting rod bearings

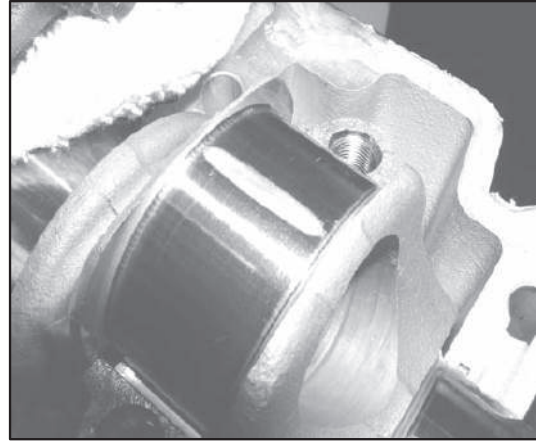

Measure small end inside diameter.

- Out of specification: Replace connecting rod

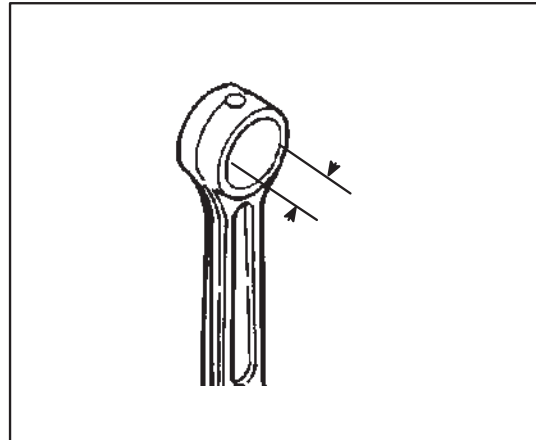

Connecting Rod Bearing Replacement Guide

Replacement of the connecting rod bearings is required when the bearing oil clearance is out of specification. Use this guide to select new bearings.

NOTE: Bearing color code is imprinted on the side of each bearing.

SPECIFIED OIL CLEARANCE: .0003" - .002" (.01mm- .064mm)

MEASURED OIL CLEARANCE: _____

ORIGINAL INSTALLED BEARING COLOR / THICKNESS: _____

REPLACEMENT BEARING THICKNESS

RED	.0783" - .0785" (1.990 - 1.995mm)
YELLOW	.0785" - .0787" (1.995 - 2.000mm)
BLUE	.0787" - .0789" (2.000 - 2.005mm)
GREEN	.0789" - .0791" (2.005 - 2.010mm)
BROWN	.0791" - .0793" (2.010 - 2.015mm)

If the measured clearance is within specification, replace with new bearings with the same color code.

If the oil clearance is outside of specification, install the BLUE color-coded bearings and re-measure oil clearance. If the measured clearance is too small, install either a RED or YELLOW bearing. If the measured clearance is too large, install either a BROWN or GREEN bearing.

If the used bearings reveal an oil clearance of .04 and .05mm, install new bearings with the same color code.

ENGINE DISASSEMBLY / ASSEMBLY

Engine Inspection Procedures

Balance Shaft Inspection

Measure balance shaft runout at several locations.

- Out of specification: Replace balance shaft

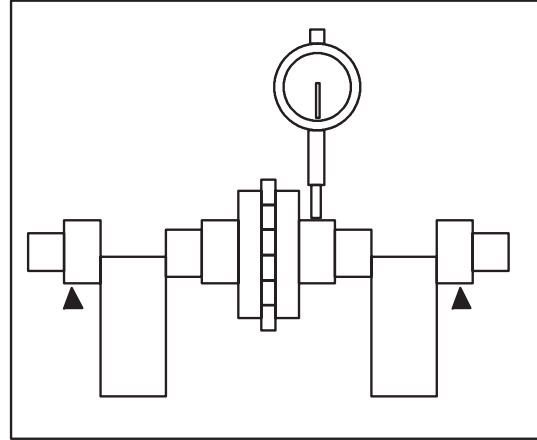

Measure bearing diameter.

- Out of specification: Replace balance shaft

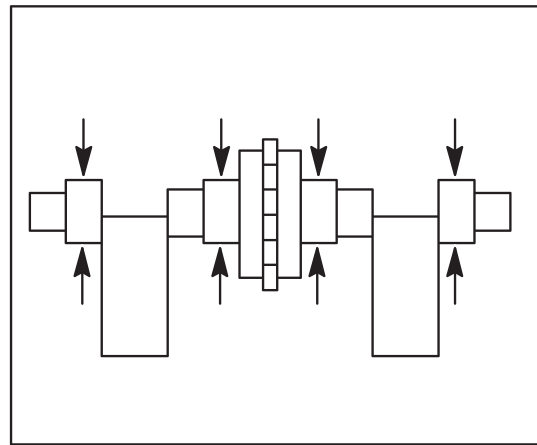

Piston Inspection

Measure piston diameter.

- Out of specification: Replace piston

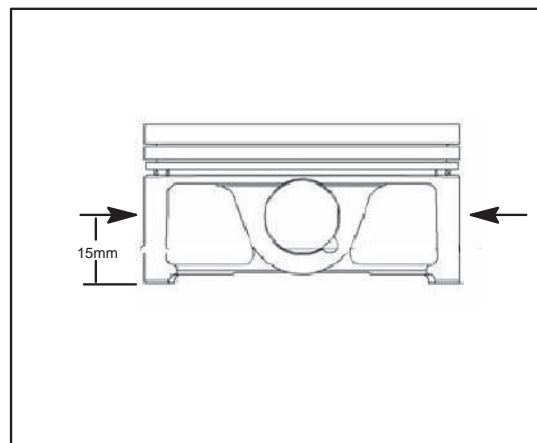

ENGINE DISASSEMBLY / ASSEMBLY

Engine Inspection Procedures

Piston Inspection

Measure piston pin boss inside diameter.

- Out of specification: Replace piston

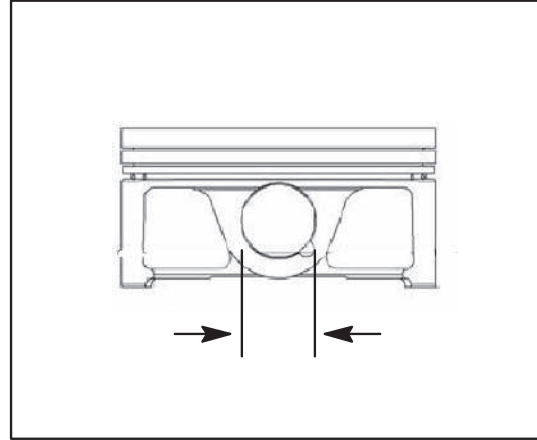

Measure piston pin outside diameter.

- Out of specification: Replace piston pin

Confirm piston-to-cylinder clearance specification.

- Out of specification: Replace piston pin

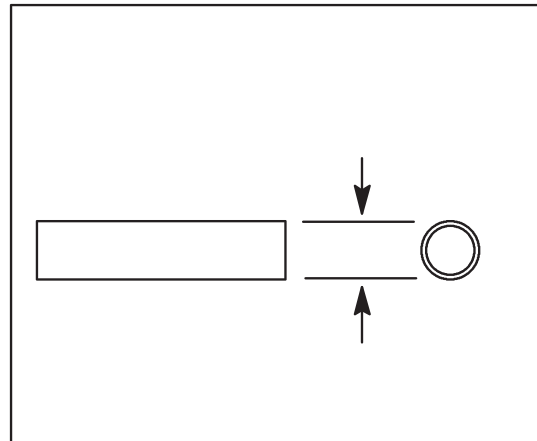

Measure installed ring end gap.

- Out of specification: Replace rings or cylinder block

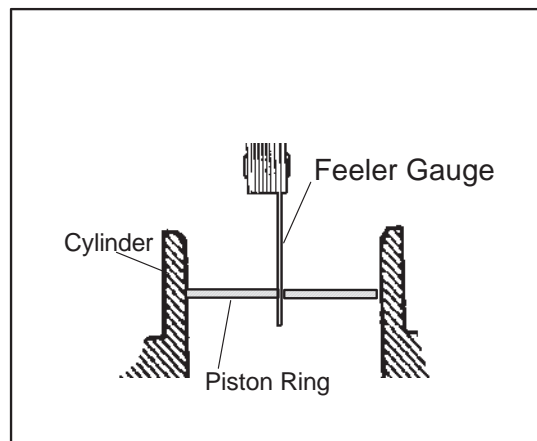

ENGINE DISASSEMBLY / ASSEMBLY

Engine Inspection Procedures

Piston Inspection

Measure piston ring groove clearance.

- Out of specification: Replace piston ring or piston

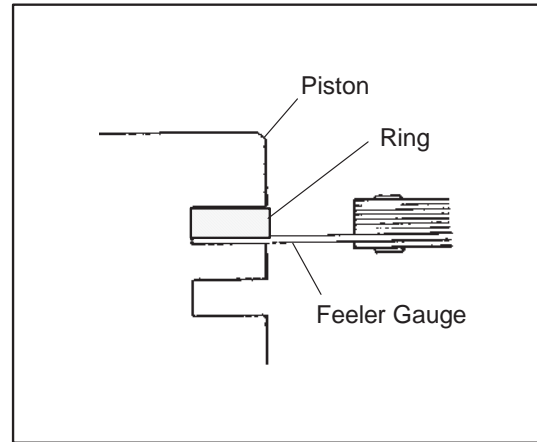

High Pressure Oil Pump Inspection

Measure relief spring free length and piston dimensions.

- Out of specification: Replace spring and piston

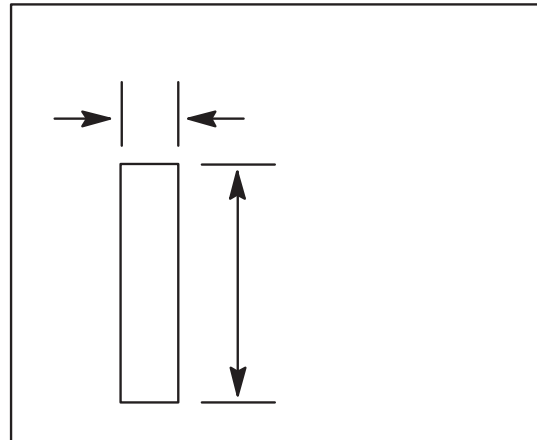

ENGINE DISASSEMBLY / ASSEMBLY

Engine Inspection Procedures

Chain Tensioner

Verify chain tensioner function.

1. Push tensioner into housing until flush with threaded housing. Tensioner should lock into place. (6 audible clicks should be heard when tensioner is pushed in from fully extended position.)
2. Once locked, push tensioner inward. Tensioner should activate and spring outwards.
 - Replace tensioner assembly if tensioner will not lock, then engage when pushed inward from locked position.

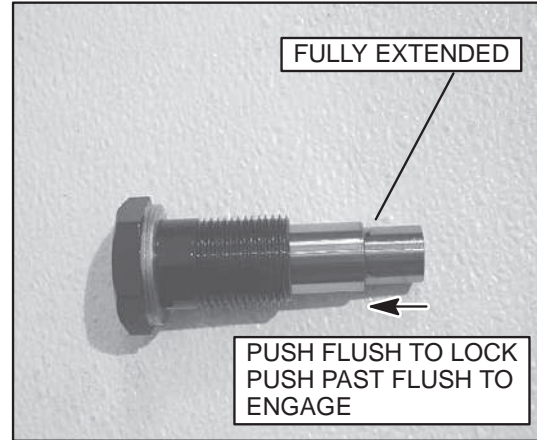

Chain Tensioner Guides

Visually inspect both chain guides.

- Replace guides if any cracking or abnormal wear and tear is found.

NOTE: Tensioner chain guide shown.



Starter Motor Clutch

Inspect clutch function.

- Clutch should move freely when rotated clockwise.
- Clutch should not rotate freely when rotated counter clockwise.
- Inspect rollers for wear and tear. Replace assembly if found.

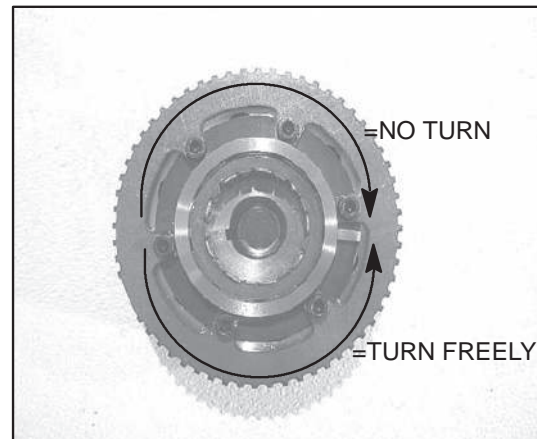

ENGINE DISASSEMBLY / ASSEMBLY

Engine Inspection Procedures

Timing Chain

Inspect timing chain.

- Replace timing chain if any damage, obvious wear and tear, or broken / mis-shaped plates are found.

Valve Removal

1. Install rocker arm shafts. Install valve spring compression tool, PN-PW-46991. Push lever down, and withdraw valve keepers.
2. The valve will now fall out of the bottom of the cylinder. Always keep the valve with its original location.



ENGINE DISASSEMBLY / ASSEMBLY

Engine Assembly

1. Remove any remaining gasket material from the upper and lower crankcase mating surfaces.
2. Remove gasket material from bedplate mating surface.
3. Clean the following parts with engine cleaning solvent:
 - Upper / Lower Crankcase
 - Cylinder Head
 - Bedplate
 - Lower Sump
 - Crankshaft / Balance Shaft
4. After cleaning parts, blow dry with compressed air.
5. With the engine facing up on stand, lubricate cylinders with engine oil.
6. Obtain both piston assemblies. Lubricate piston assemblies with engine oil.
7. Install the upper and oil control rings with the markings facing upwards.

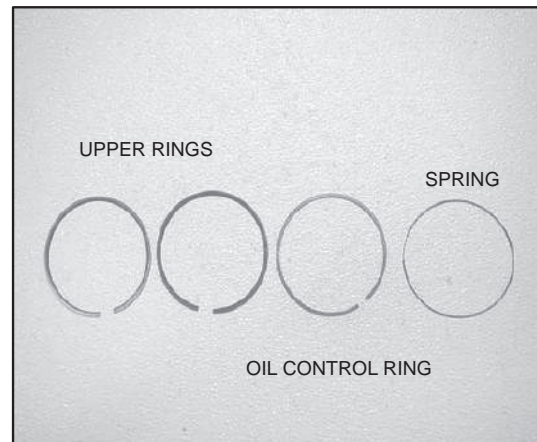
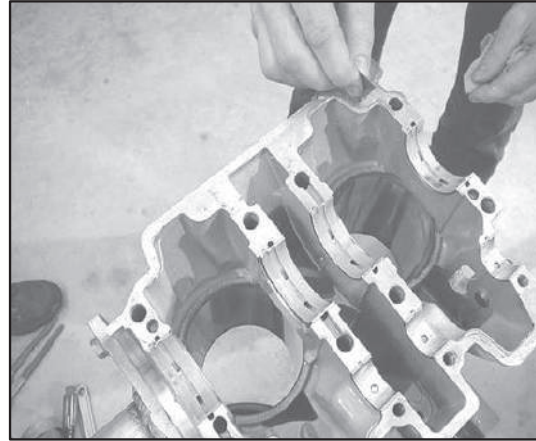

8. Place ring compressor tool, PN-PW-46983 on top of one cylinder. Align the ring end gaps as outlined in the photo. The piston mark will face the INTAKE SIDE of the engine once installed into the cylinder.

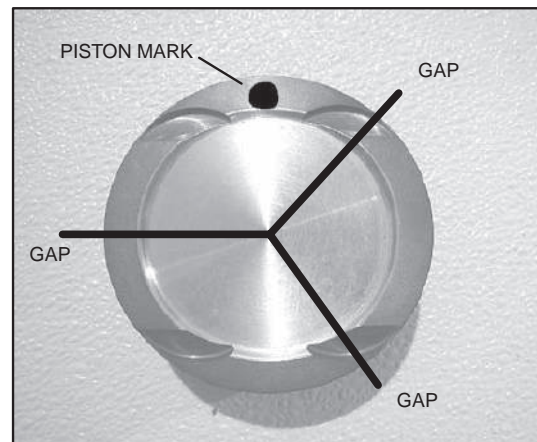

ENGINE DISASSEMBLY / ASSEMBLY

Engine Assembly

9. Carefully install each piston assembly into the cylinders. Take care in not scratching the cylinder bore.
10. Install the intake-side chain guide. Tighten fastener to specification.
11. Carefully rotate engine 180°. Do not allow the pistons to fall out of cylinders.
12. Select and install the connecting rod, crankshaft main bearings, and balance shaft bearings. (Selection is made using bearing selection process described in this chapter.)
13. Coat all bearings and journals with engine oil. Install water pump drive gear into crankcase.
14. Install the chain tensioner guide into the exhaust-side of the crankcase. Tighten fastener to specification.

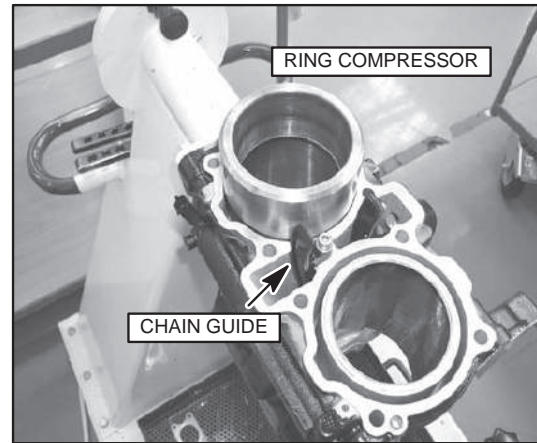

15. Install the balance shaft with the gear facing the front of the engine.

NOTE: Verify bearing surfaces are centered within journals.

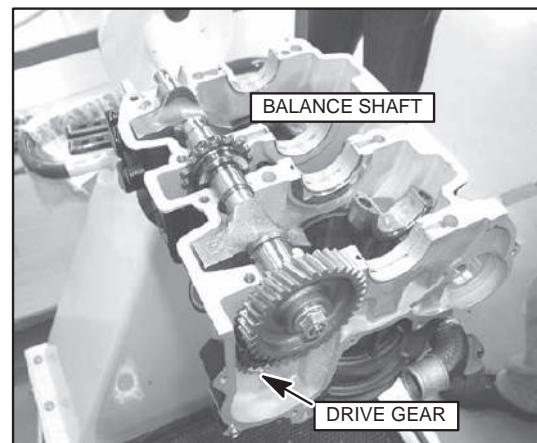

16. Install crankshaft so that the two single-dot alignment marks located on the balance shaft gear and crankshaft gear face each other.

NOTE: Verify bearing surfaces are centered within journals.

17. Coat bearing surfaces with engine oil.

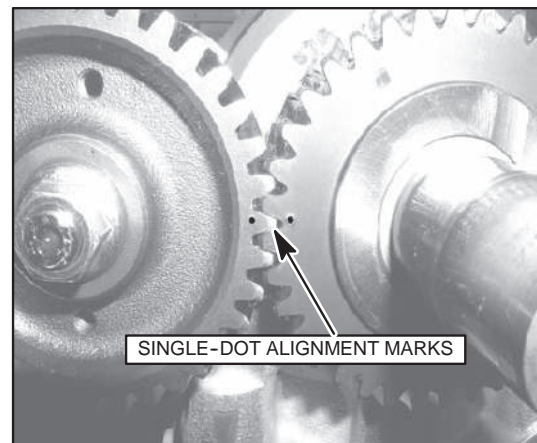

ENGINE DISASSEMBLY / ASSEMBLY

Engine Assembly

18. Push pistons so the connecting rods engage the crankshaft. Obtain the two con-rod caps with bearings installed. Apply engine oil to connecting rod bearings.
19. Match each unique cap mating surface with the appropriate connecting rod. Loosely install each fastener, then tighten evenly.
20. Torque connecting rod cap bolts to specification.

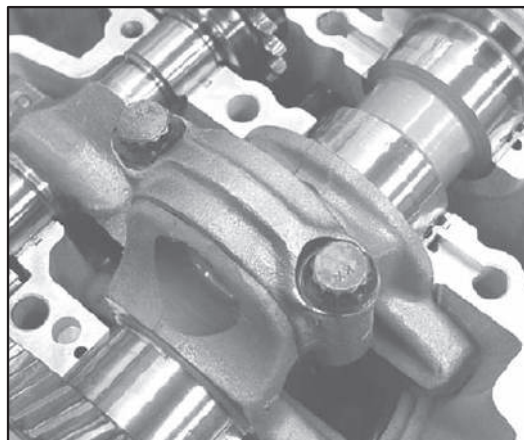

21. Verify the lower and upper crankcase mating surfaces are free from engine oil or foreign material.
22. Apply a thin, even bead of Three Bond 1213™ case sealant to the upper crankcase mating surface.

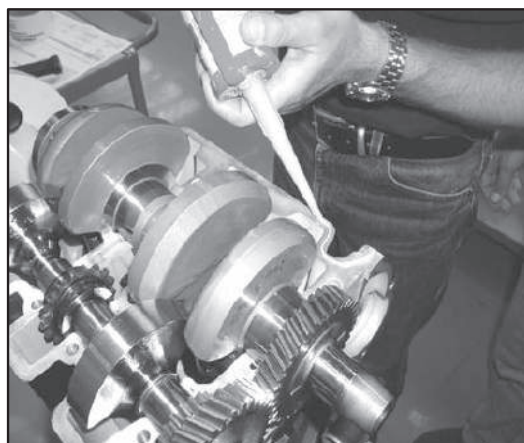

23. Apply sealant as outlined in photo.

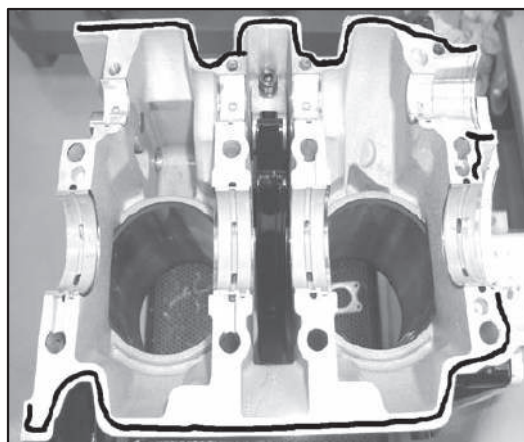

ENGINE DISASSEMBLY / ASSEMBLY

Engine Assembly

24. Verify the crankcase stud oil jackets are installed on the four studs as outlined in the photo.

NOTE: Verify stud jackets are installed in the middle of each stud.

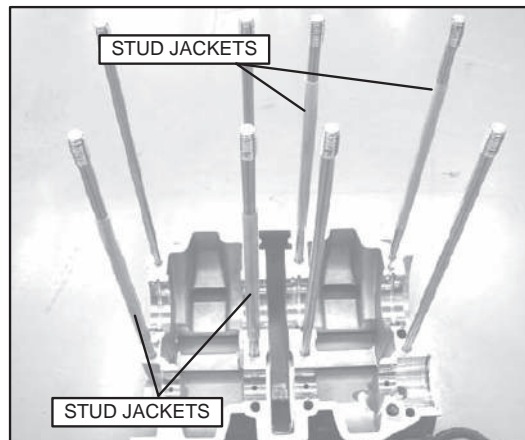

25. Carefully install the lower crankcase on to the upper crankcase.

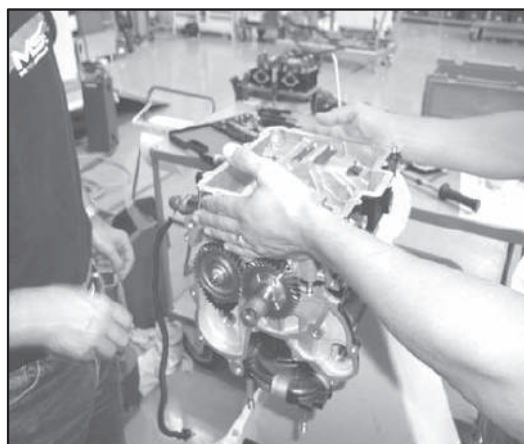

26. Loosely install two of the four lower crankcase fasteners.

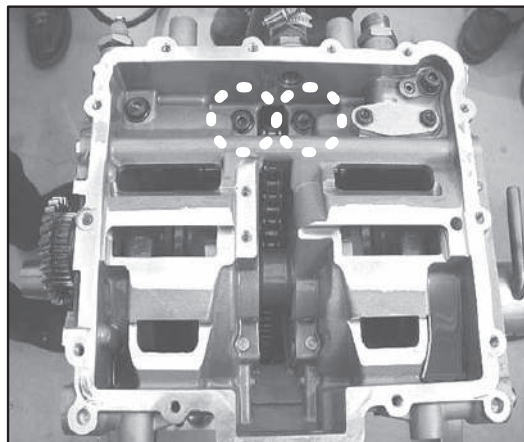

ENGINE DISASSEMBLY / ASSEMBLY

Engine Assembly

27. Apply a light film of grease to the crankshaft seal. Install the seal around the flange. Evenly press seal into crankcase.

CAUTION!: Use extreme care when installing seal. Do not fold seal lips over when pressing around flange.

28. Rotate the engine 180° so the pistons face upwards.

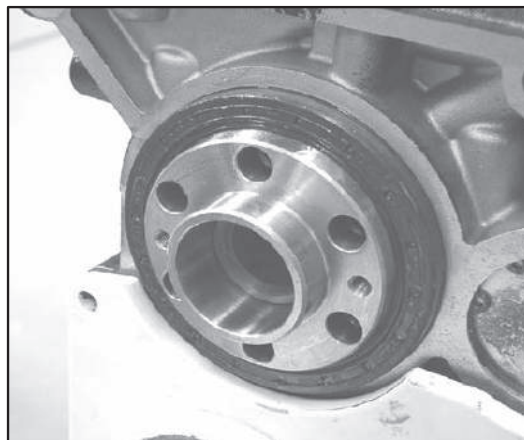

29. Clean the cylinder head mating surface free from oil and foreign material. Install a new cylinder head gasket with the part numbers and markings facing up and the larger coolant slots located on the exhaust-side of the engine.

NOTE: Always use a new cylinder head gasket, regardless of original condition.

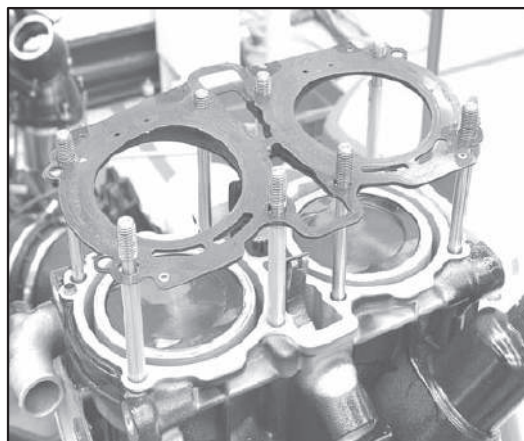

30. Install the cylinder head over the stud bolts with the exhaust manifold studs facing the oil filter side of the engine.
31. Apply engine oil to stud threads and loosely install the cylinder head nuts.

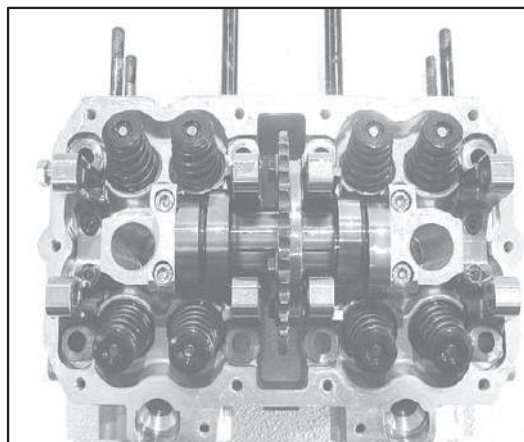

ENGINE DISASSEMBLY / ASSEMBLY

Engine Assembly

32. Rotate the engine 180°. (Cylinder Head Down)
33. Install the oil pump relief valve piston and spring. Place cover over spring and insert fastener. Hand-tighten fastener.
34. Install the remaining lower crankcase fastener.
35. Rotate the engine 180°. (Cylinder Head Up)
36. Tighten cylinder head nuts and lower crankcase fasteners to specification as outlined on page 4.15.
37. Rotate the engine 180°. (Cylinder Head Down)
38. Proceed with the TIMING CHAIN INSTALLATION / TDC PROCEDURE.

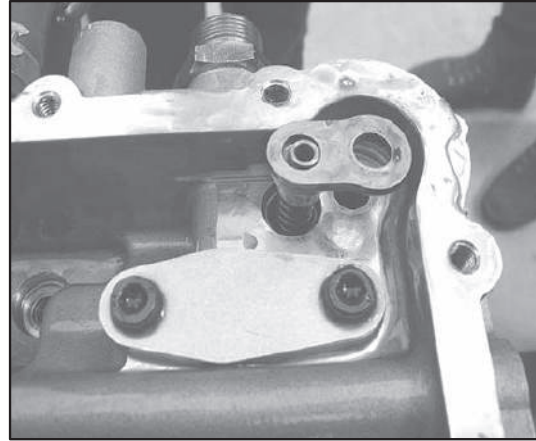

ENGINE DISASSEMBLY / ASSEMBLY

Timing Chain Installation / TDC Procedure

A special procedure is required for installing the timing chain into the engine. Four service tools are required when installing the timing chain and setting the engine timing. They are:

- Timing Chain Installation Guide PN-PW-47079
- Timing Chain Hook / Stuffer PN-PW-47108
- Crankshaft Turning Hand Crank PN-PW-46981
- Camshaft Alignment Tool PN-PW-47077

Timing Chain Installation

1. Remove the rocker arm pins and rocker arms from the cylinder head.
2. Install the Crankshaft Hand Crank Tool into the nose of the crankshaft. Set the jam nut so the crankshaft can be turned left or right.
3. Rotate the crankshaft until double-dot alignment marks on each gear face each other. (The engine will be set to BDC when the two sets of double dots face each other.)

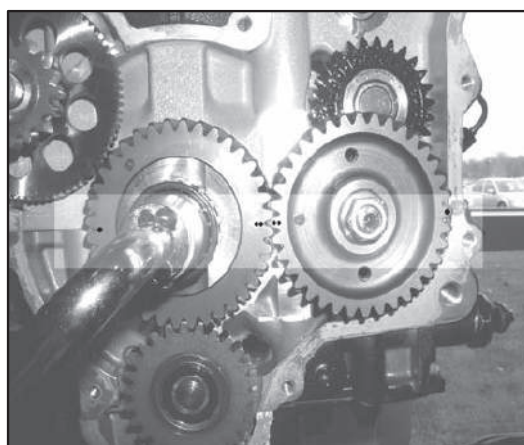

4. Install the the Timing Chain Installation Guide, PN-PW-47079, into the two bedplate fastener bores.

NOTE: The Timing Chain Installation Guide tool will guide the chain around the crankcase bends while preventing the chain from catching on the balance shaft sprocket.

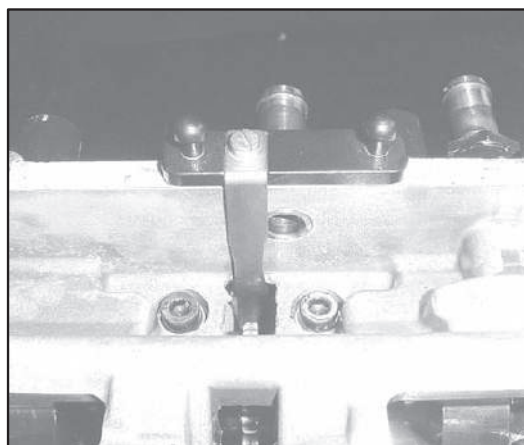

ENGINE DISASSEMBLY / ASSEMBLY

Timing Chain Installation

5. Slowly insert the chain into chain gallery. Wiggle the chain slightly until it falls down through the engine and protrudes from the bottom of the cylinder head.

CAUTION!: Do not drop the chain into the engine.

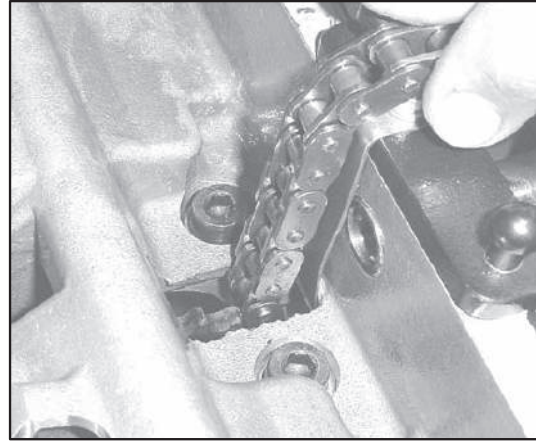

6. Insert the stuffer end of the Timing Chain Hook / Stuffer, PN-PW-47108, tool into the chain gallery.

NOTE: The stuffer wedge will prevent the chain from catching on the sprocket.

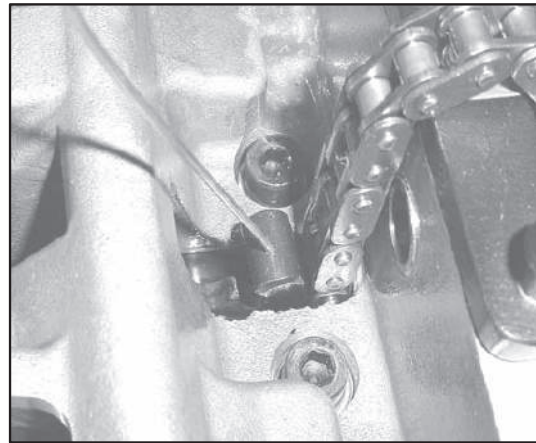

7. Allow three to four chain links to fall past the cylinder head parting line.

NOTE: Verify the chain is not caught on the balance shaft sprocket and that the marks on the gears are still in alignment!

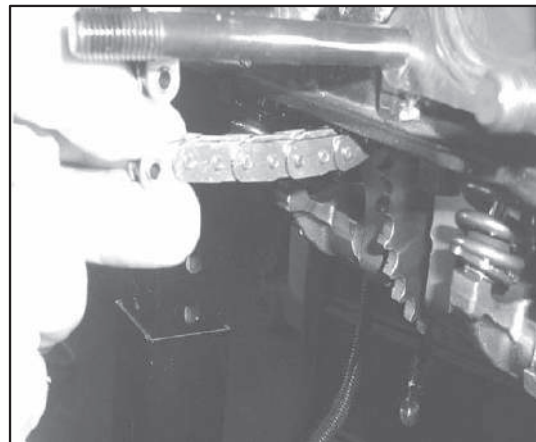

ENGINE DISASSEMBLY / ASSEMBLY

Timing Chain Installation

8. Wrap the chain around the camshaft sprocket.

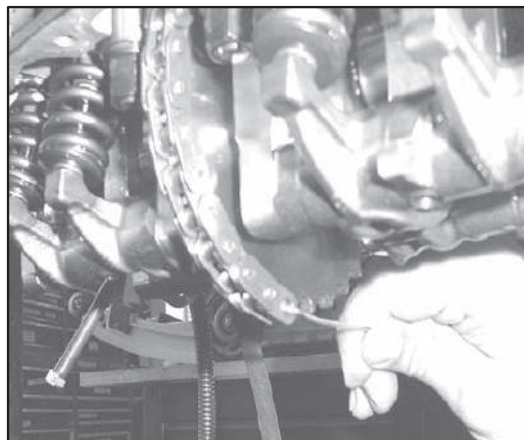

9. While firmly holding the chain against the camshaft sprocket, remove the stuffer, and wrap the chain around the balance shaft sprocket and under the crankcase support member.

NOTE: The hooked-end of the Timing Chain Hook / Stuffer Tool will simplify pulling the chain around the sprocket.

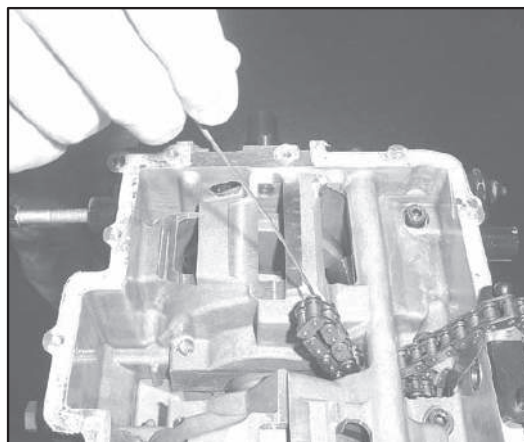

10. Carefully drop the chain UNDERNEATH the crankshaft and around the chain guide.

NOTE: Do not drop the chain around the OUTSIDE of the crankshaft. When performed properly, the chain should drop easily through the engine and protrude from the cylinder head.

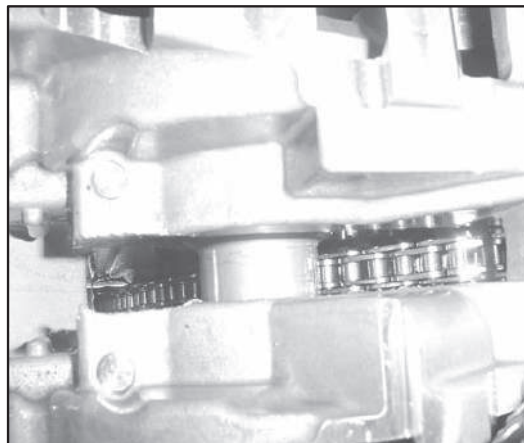

ENGINE DISASSEMBLY / ASSEMBLY

Timing Chain Installation

11. Rotate the camshaft until one of the holes in the PTO-end points to the floor.
12. Install the Camshaft Alignment Tool, PN-PW-47077, into the hole, press against the rocker arm towers.

NOTE: The Camshaft Alignment Tool will lock the camshaft into the correct timing position in relation to the crankshaft and balance shaft.

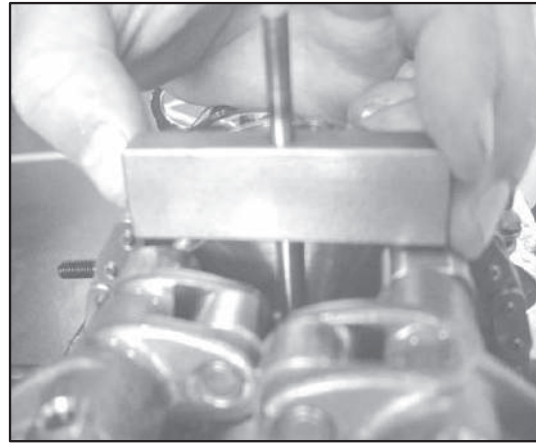

13. Wrap chain around camshaft sprocket and secure links with new pins and plate assembly.

NOTE: Do not use the chain crimper to assemble chain links at this time.

14. Rotate the engine 180°. (Cylinder Head Up)
15. Carefully rotate the crankshaft until the timing marks on the gears are pointing at each other. The valve train should resemble the illustration below.

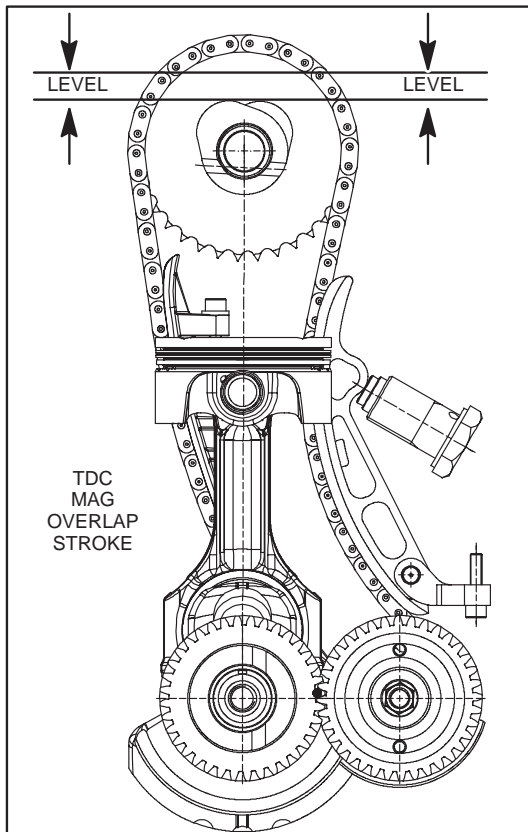
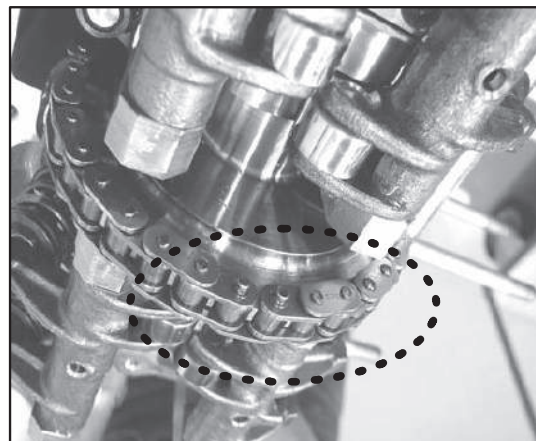

ENGINE DISASSEMBLY / ASSEMBLY

Engine Assembly

1. Reassemble the timing chain with a new plate. Crimp the new chain pins and plates together using the Chain Breaker Tool, PN-PW-46985.

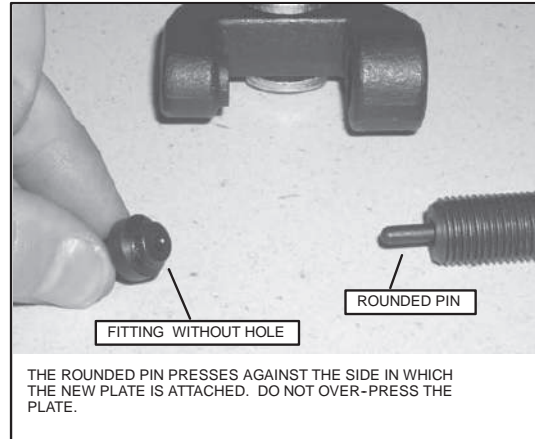

2. Verify the chain tensioner is set in the locked position. To set the chain tensioner, grasp end in palm of hand, and press assembly down on a hard surface. The tensioner is set in the locked position when it is flush with the tensioner housing.
3. Install the chain tensioner into the crankcase. Tighten housing cap to specification.

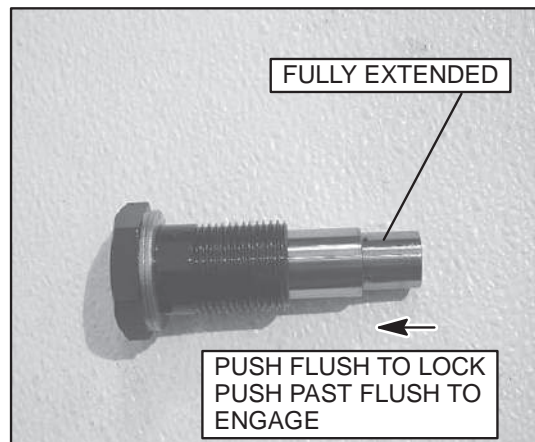

4. Insert the blade of a flat head screwdriver between the tensioner and the tensioner rail guide.

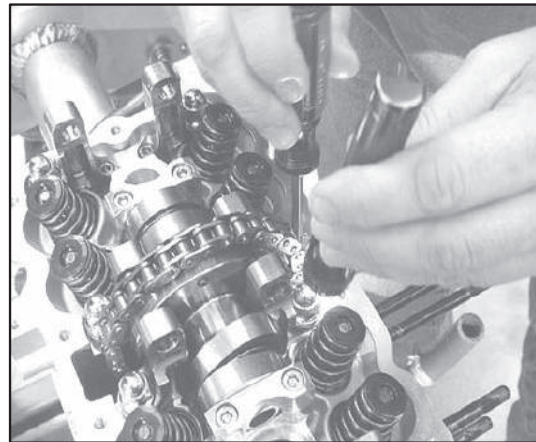

ENGINE DISASSEMBLY / ASSEMBLY

Engine Assembly

5. Verify the blade of the screwdriver contacts the face of the tensioner.
6. Push the blade of the screwdriver against the tensioner face and twist. Do this until the tensioner goes in past flush and activates.
7. Once activated, there should be no slack present in the timing chain.

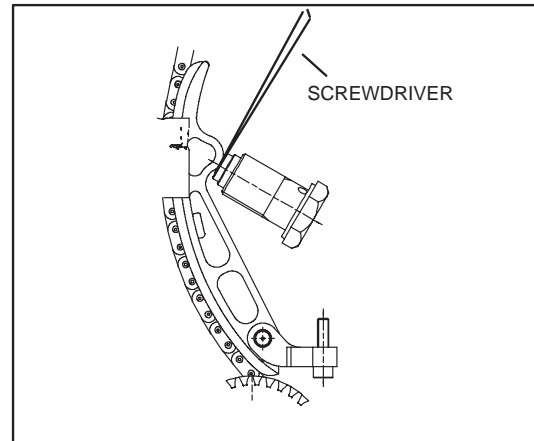

8. Install low pressure pump and screen into bedplate. Clean bedplate and lower crankcase mating surfaces.
9. Apply a thin bead of Three Bond 1215™ to the mating surface and Install the bedplate. Tighten fasteners to specification.
10. Install the high pressure oil pump assembly as outlined on page 4.12.
11. Rotate the engine 180°. (Cylinder Head Up)

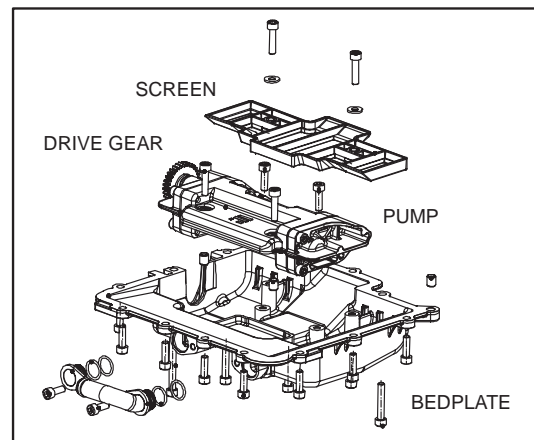

12. Coat the gears located at the front of the engine with engine oil.
13. Install the starter motor gear, low pressure oil pump idler gear.

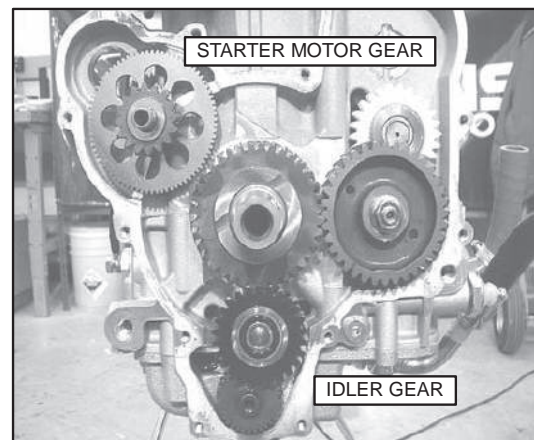

ENGINE DISASSEMBLY / ASSEMBLY

Engine Assembly

14. If the starter motor was removed, reinstall and tighten fasteners to specification.
15. Attach the starter motor battery cable to the motor at this time.

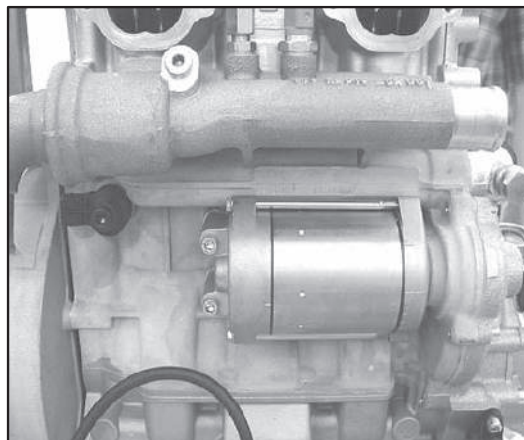

16. Press the water pump shaft into the mechanical seal.
17. Apply a thin bead of Three Bond 1215™ to the front gear cover mating surface.
18. Install the front gear cover. Tighten fasteners to specification.

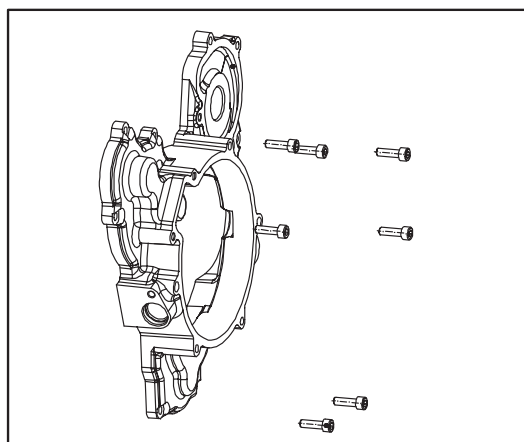

19. Install the water pump impeller. Tighten impeller nut to specification.
20. Install water pump housing and coolant hose. Tighten fasteners to specification.

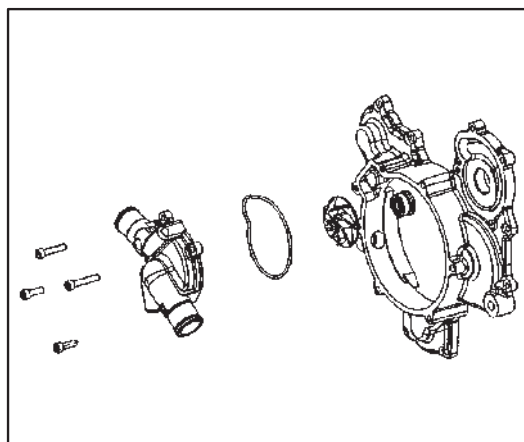

ENGINE DISASSEMBLY / ASSEMBLY

Engine Assembly

21. Apply a generous amount of engine oil to the crankshaft end and roller bearings.
22. Install the roller bearing, starting gear, and flywheel key into end of crankshaft.
23. Install the flywheel on to the crankshaft. Verify flywheel fits over key.
24. Apply Loctite™ 262 to flywheel bolt, and install.

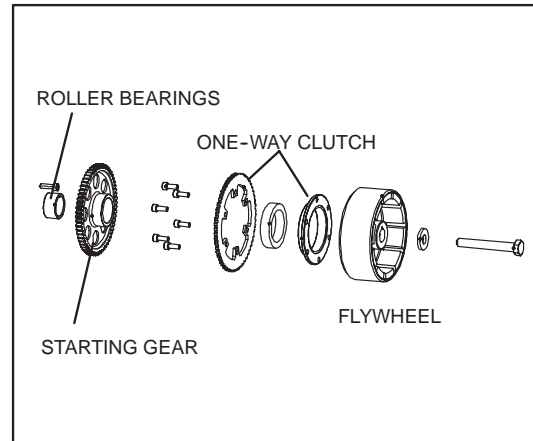

25. Install two of the PTO coupler bolts into the PTO-end of the crankshaft. Have an assistant place a pry bar across these two bolts to prevent the crankshaft from rotating.

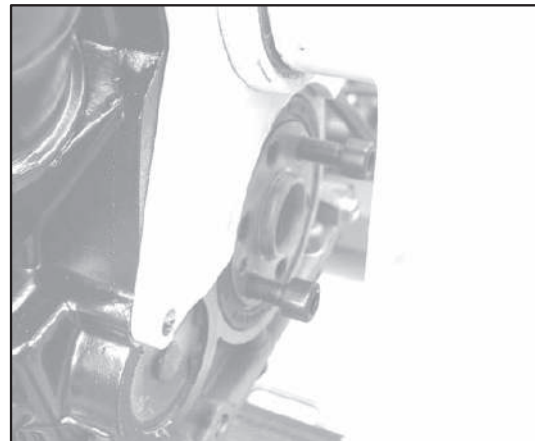

26. Tighten flywheel bolt to specification.



ENGINE DISASSEMBLY / ASSEMBLY

Engine Assembly

27. Apply a thin bead of Three Bond 1215™ sealant to stator cover mating surface.
28. Install stator cover with stator mounted inside of cover. Route harness as not to pinch or cut wires.

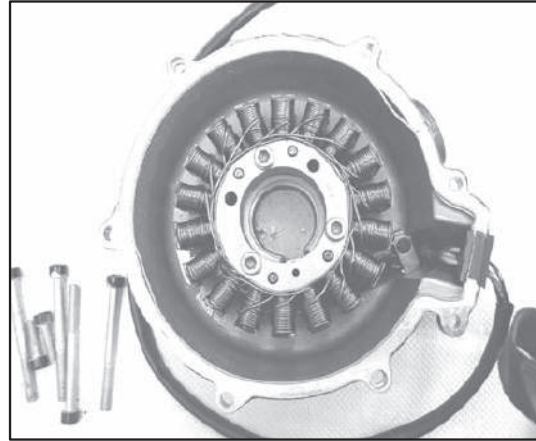

29. Reinstall the two high-pressure oil supply hoses and banjo bolt to the top of the cylinder head.
30. Tighten banjo bolt to specification.

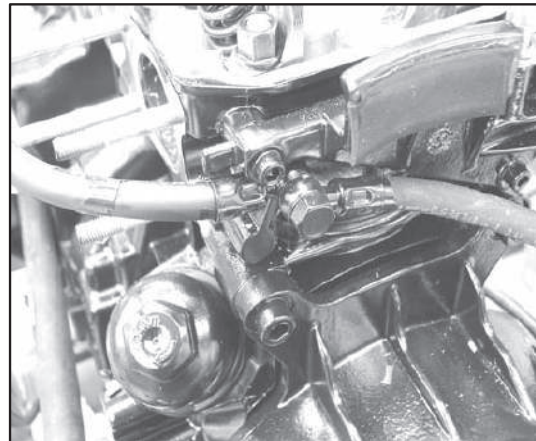

NOTE: Before installing the valve cover and gaskets, the valve clearance must be checked. Follow the procedure outlined in chapter two. Replace any valve clearance shims that are out of specification or worn.

After completing the valve clearance adjustment, reinstall the valve cover using new gaskets and o rings.

ENGINE DISASSEMBLY / ASSEMBLY

Engine Cooling System

The MSX 110 and 150 engine packages feature two independent cooling circuits. The first is the **FRESHWATER** circuit. The freshwater cooling circuit is responsible for cooling the intercooler, water-to-water heat exchanger, oil storage tank, exhaust manifold / turbine housing, and exhaust system.

The second cooling circuit is the **INTERNAL ENGINE** circuit. The internal engine cooling circuit is responsible for cooling the cylinder head, oil cooler, and turbocharger bearing house. Heat absorbed into the internal engine circuit is dissipated to the freshwater circuit inside of the water-to-water heat exchanger.

Freshwater Cooling Circuit

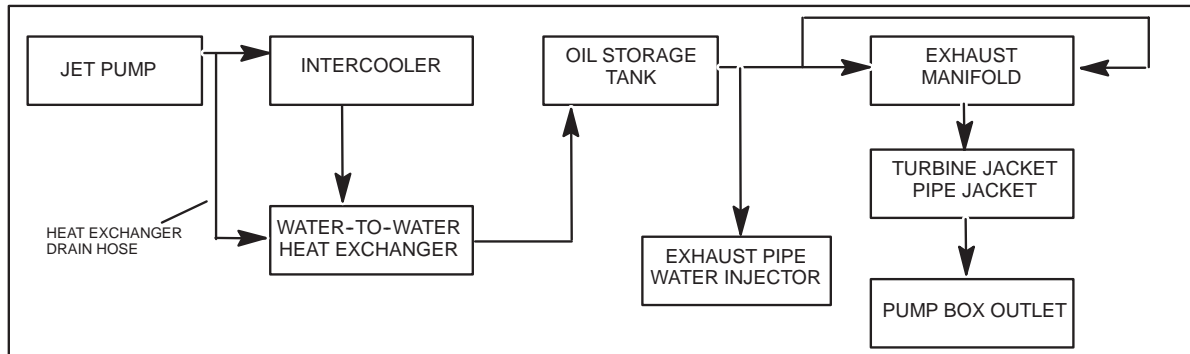

Internal Engine Cooling Circuit

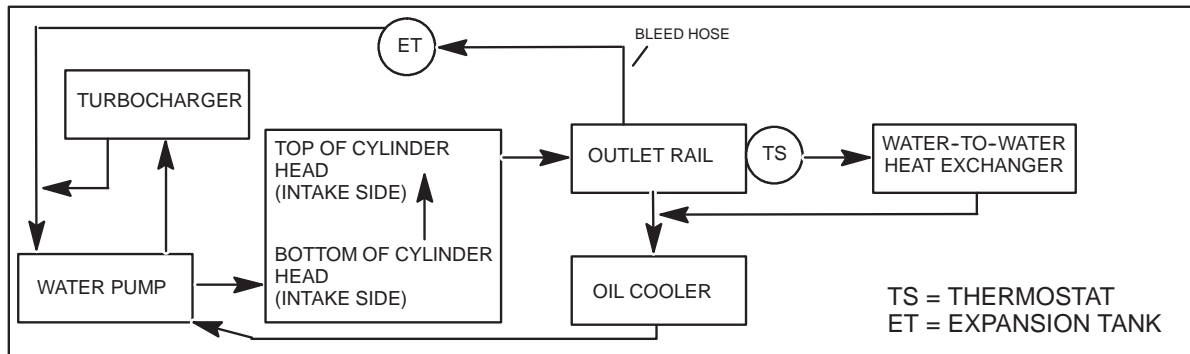

Cooling System Specifications

Internal Engine Coolant	50/50 Distilled Water / Propylene Glycol
Internal Engine Coolant Capacity	3.5 US Quarts (3.3 Liters)
Thermostat Opening Temperature	180° F (82° C)
Internal Engine Circuit Operating Pressure	14.6 psi (1 Bar)
Exhaust Stream Injector Orifice Size	.185"

ENGINE DISASSEMBLY / ASSEMBLY

Thermostat Removal / Installation

NOTE: Coolant will flow out of the cylinder head into the bilge when the outlet rail elbow is removed. Tilt the bow down to prevent coolant from escaping outlet rail.

1. Remove the snap ring using a snap ring pliers.
2. Carefully twist and pull the elbow out of the rail.
3. Inspect the o rings. Replace if found worn or damaged.
4. Remove and replace thermostat.
5. Insert thermostat with bleed hole up.
6. Reinstall the elbow. Reinstall the snap ring. Verify the snap ring chamfer faces out when installing.

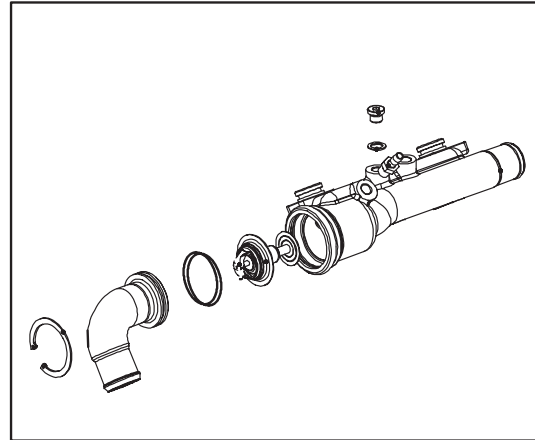

Water Pump Removal / Installation

NOTE: The engine must be removed to access the water pump housing.

1. The water pump cover can be removed by 4 fasteners that mount the cover to the front gear cover.
2. Always replace the o ring with new during reassembly.
3. The impeller can be removed by holding the crankshaft stationary while turning the impeller nut counter-clockwise.
4. Tighten fasteners to specified torque outlined at beginning of chapter.

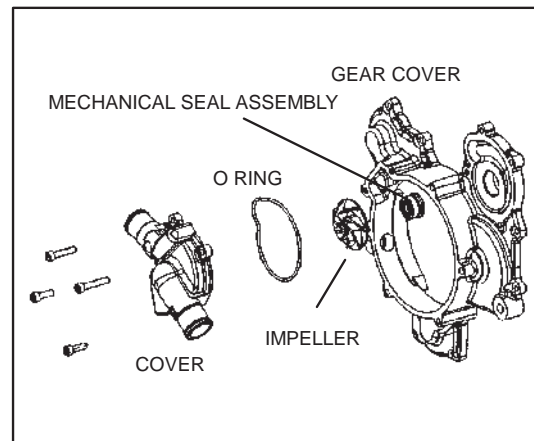

1. To replace the impeller shaft and mechanical seal, remove the front gear cover.
2. Carefully extract mechanical seal components out of the gear cover.
3. Press new gasket with washer recess facing out, washer with grooves facing gasket, and new mechanical seal, with spring-end facing outward into cover using light and even force.
4. The impeller shaft sits inside crankcase bore. Replace shaft if worn or damaged.
5. Tighten fasteners to specified torque outlined at beginning of chapter.

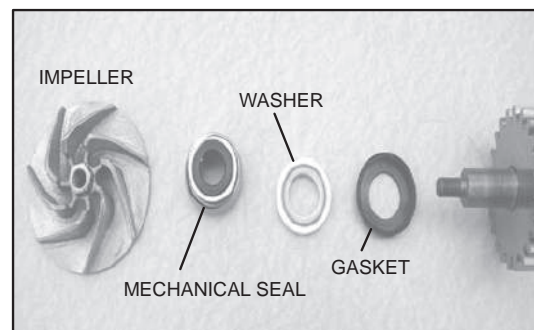

ENGINE DISASSEMBLY / ASSEMBLY

Freshwater Circuit Cooling Hose Routings

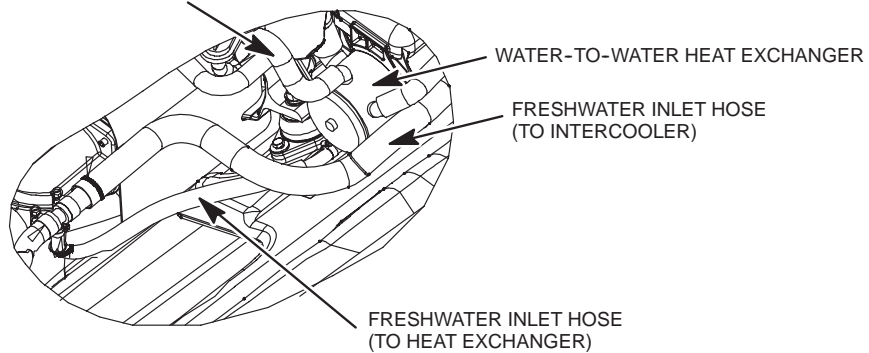
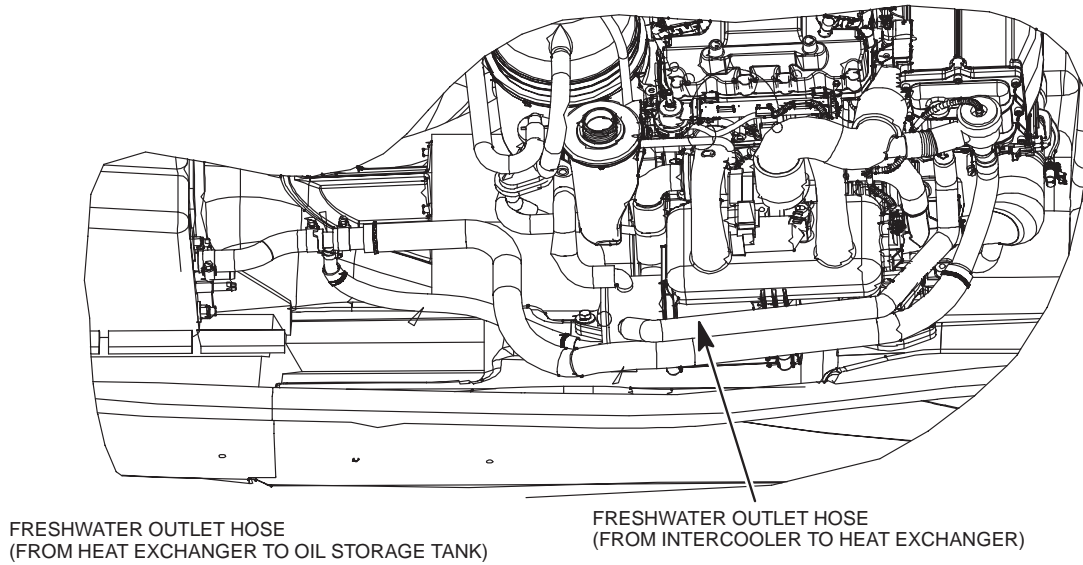
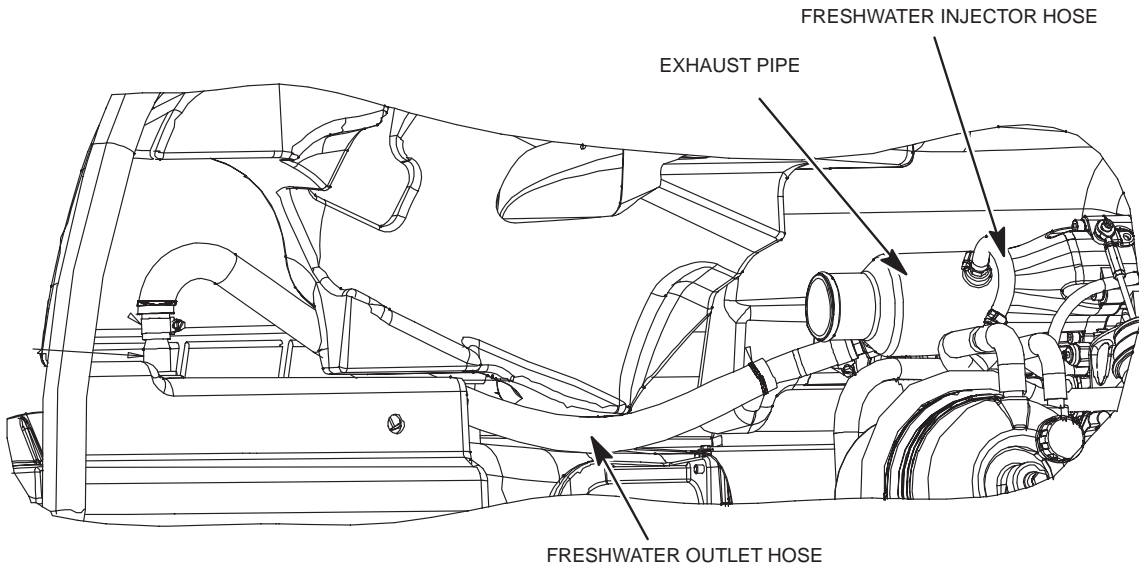

ENGINE DISASSEMBLY / ASSEMBLY

Freshwater Circuit Cooling Hose Routings

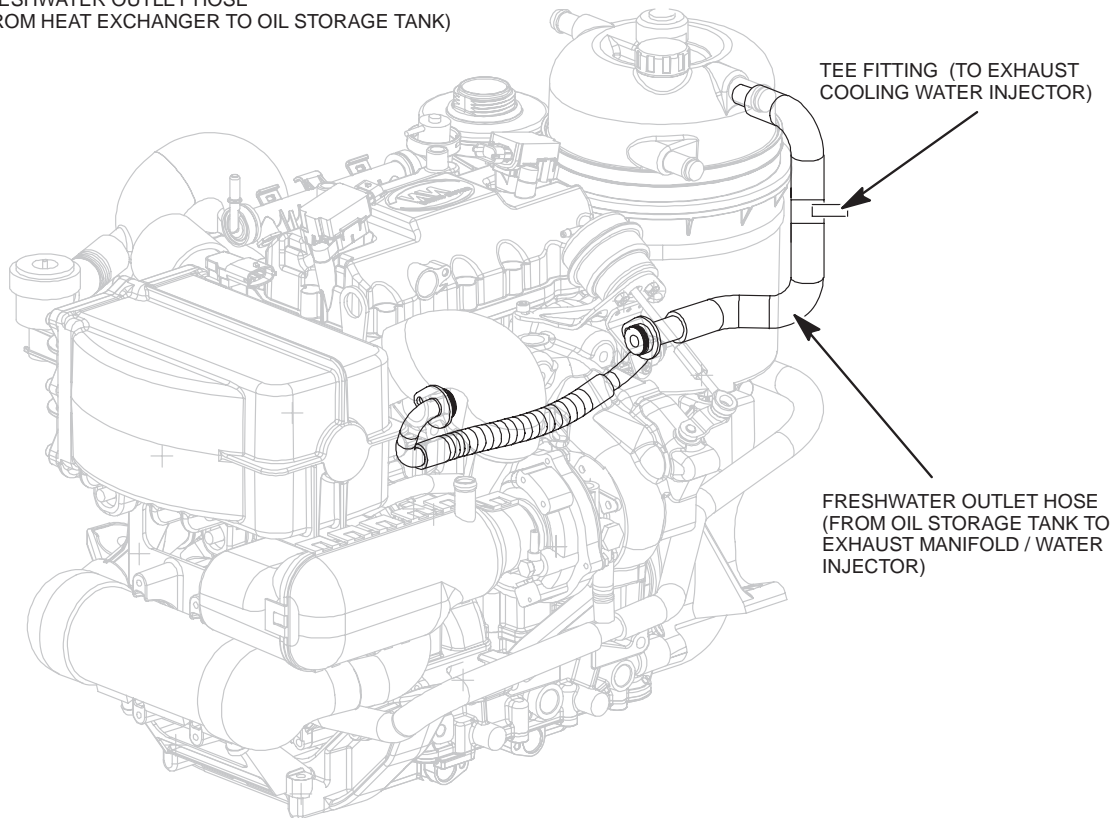
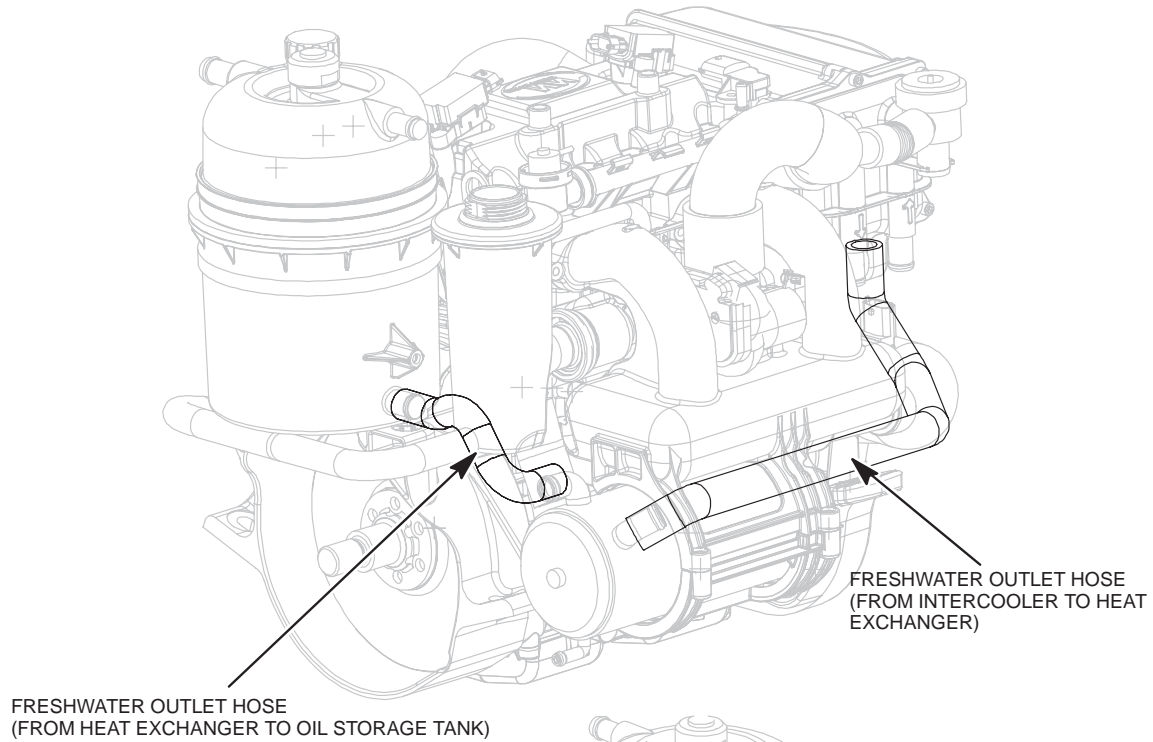

ENGINE DISASSEMBLY / ASSEMBLY

Internal Engine Coolant Hose Routing - Top View

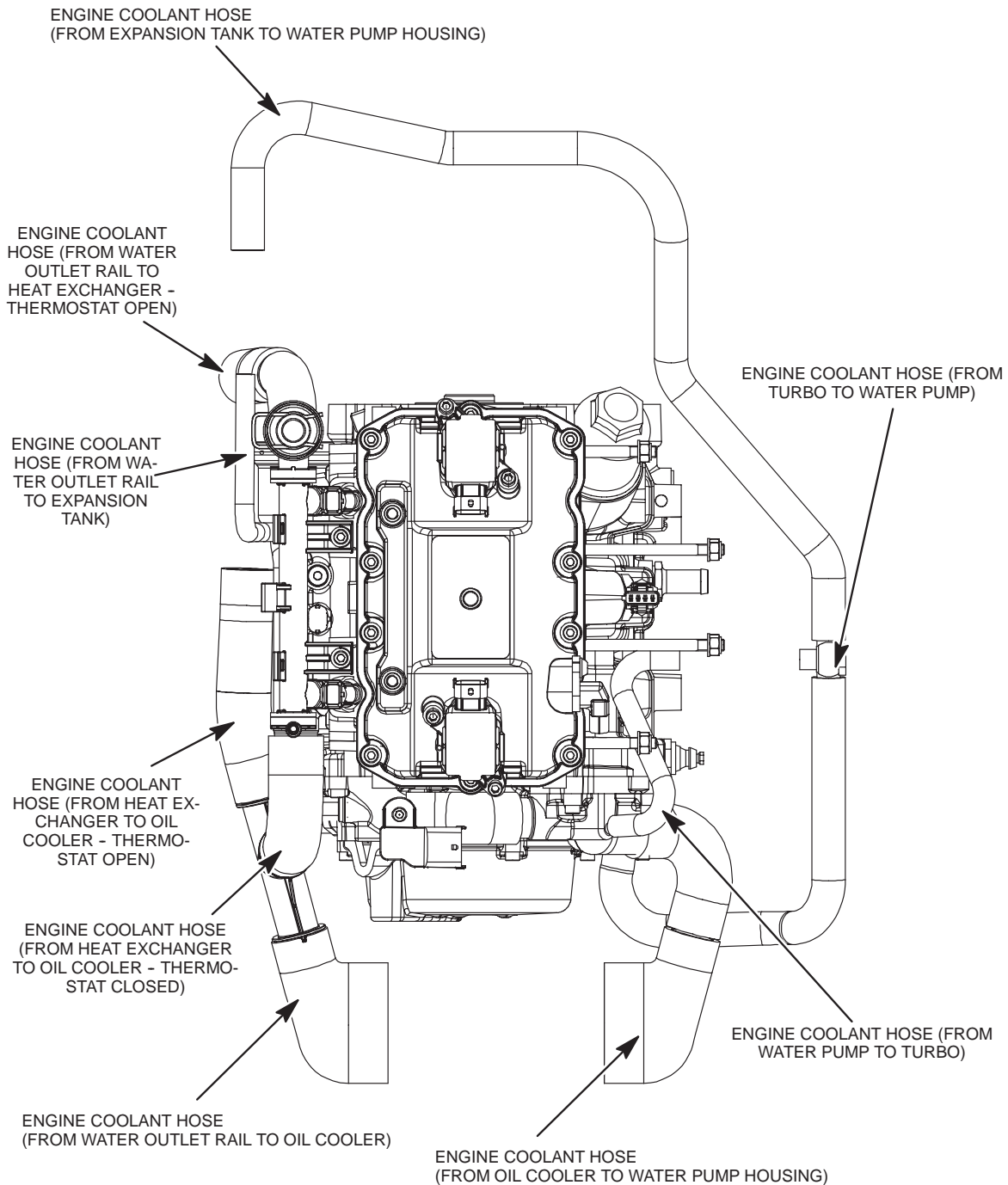

ENGINE DISASSEMBLY / ASSEMBLY

Internal Engine Coolant Hose Routing - Front View

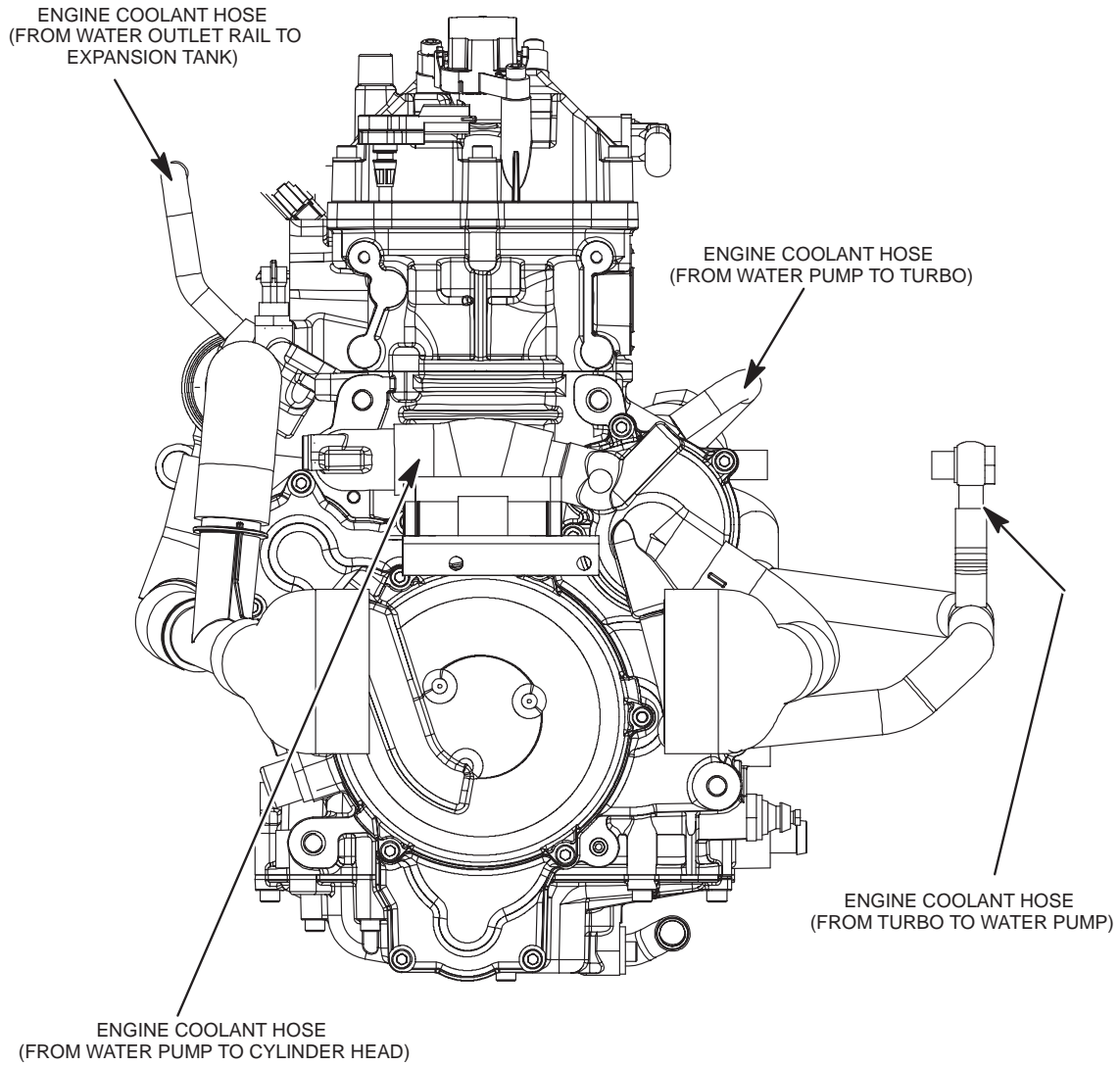

ENGINE DISASSEMBLY / ASSEMBLY

Internal Engine Coolant Hose Routing - Right View

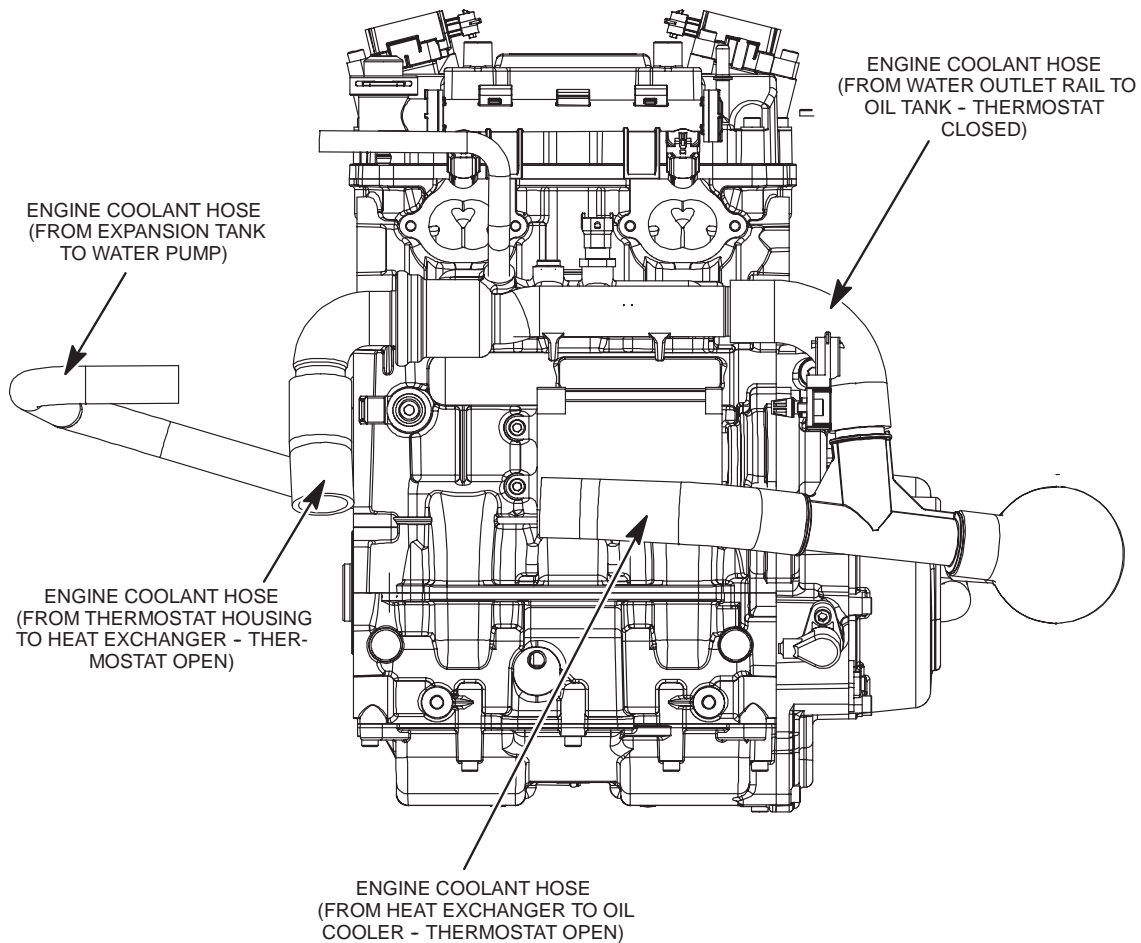

ENGINE DISASSEMBLY / ASSEMBLY

Oil Lubrication System

The lubrication system features two oil pumps. The first pump is the low pressure pump that pumps oil to the oil cooler, and then on to the oil storage tank. The second pump, high pressure, is located on the PTO end of the engine crankcase. The high pressure pump draws oil in from the oil storage tank, and supplies oil to all of the internal engine components. The low pressure pump supplies approximately twice the amount of oil to the oil storage tank than what the high pressure pump requires. This ensures a constant supply of oil.

A small amount of pressurized oil is supplied to the turbocharger bearing house and oil storage tank anti-siphon valve. The anti-siphon valve is located on top of the oil storage tank. The valve works by preventing oil from the tank to back-feed into the engine in the even that oil pressure is lost. (Watercraft Rollover)

Low Pressure Oil Circuit

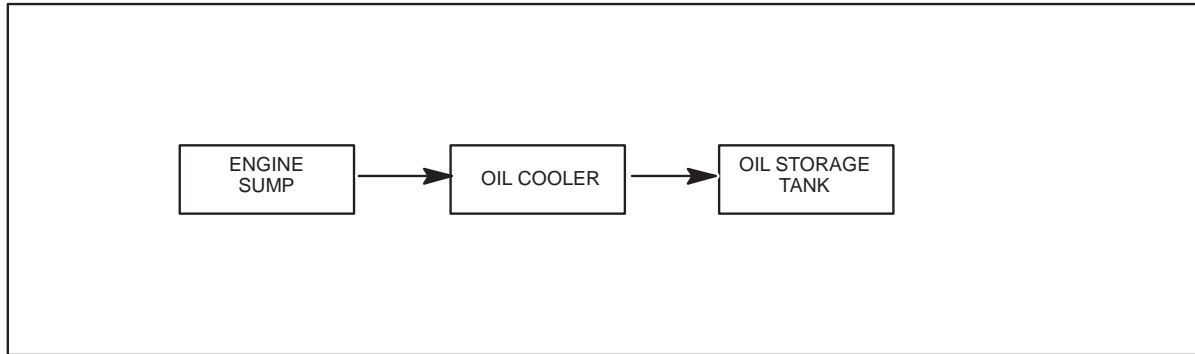

High Pressure Circuit

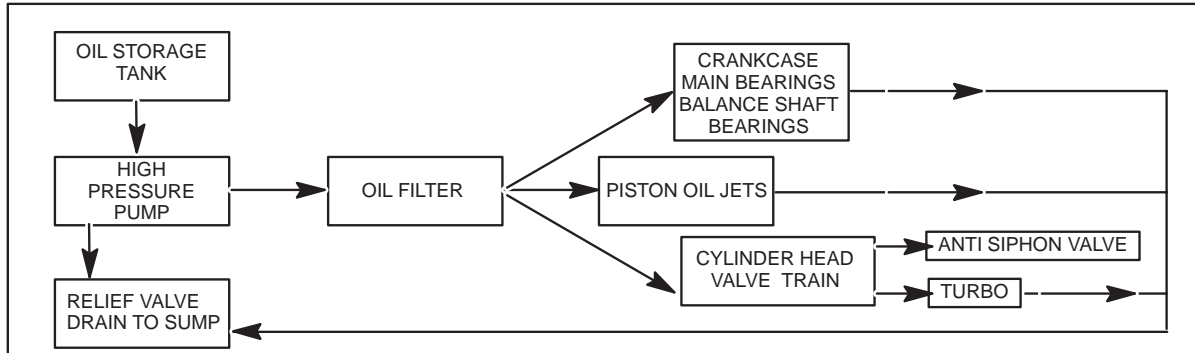

ENGINE DISASSEMBLY / ASSEMBLY

Crankcase Ventilation

Engine blow-by is recovered via the oil separator or cyclone. The oil separator is located on the oil storage tank. Engine oil and fuel vapors are collected in the top housing of the oil storage tank. These vapors are routed to the separator. Heavy elements such as oil and unburned fuel are collected at the bottom of the separator and are routed back to the crankcase sump. The remaining vapors are collected at the top of the separator and routed to the air intake flame arrestor where they are drawn into the intake air stream and burned.

Crankcase Ventilation Circuit

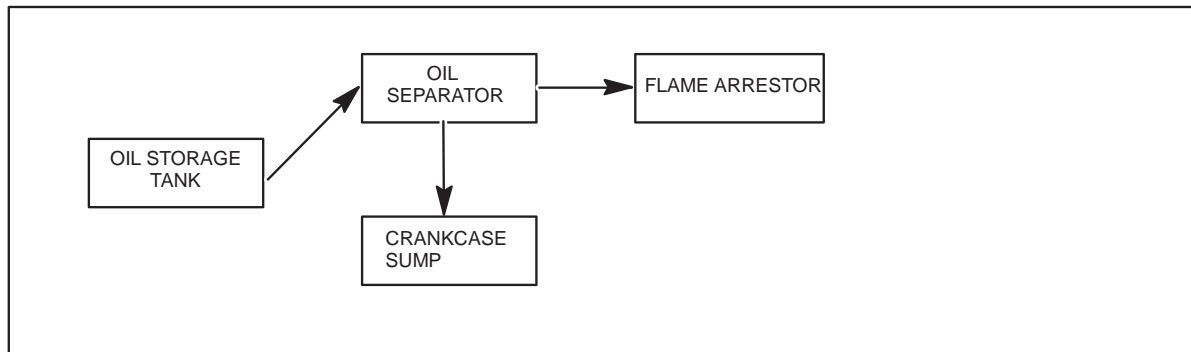

Low Pressure Pump Removal / Installation

NOTE: The engine must be removed to access the low pressure pump.

1. Remove the crankcase bedplate from the lower crankcase.
2. Remove the fasteners securing the screen to the bedplate and pump.
3. Remove the pump from the bedplate.

NOTE: The low pressure pump is not serviceable and must be replaced as one component is when operation is suspect.

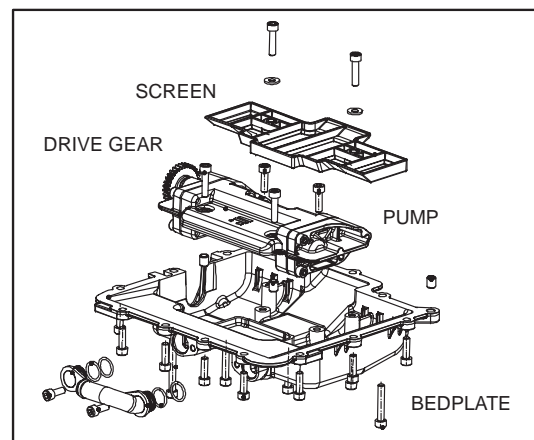

High Pressure Pump Removal / Installation

NOTE: The engine must be removed to access the high pressure pump.

1. Remove snap ring. Carefully extract rotor cover from crankcase.
2. Extract outer and inner rotors from bore. Remove timing rotor from shaft.
3. Carefully remove timing key.

NOTE: Always use a new timing key and o rings during pump assembly.

NOTE: Verify snap ring bevel faces outward.

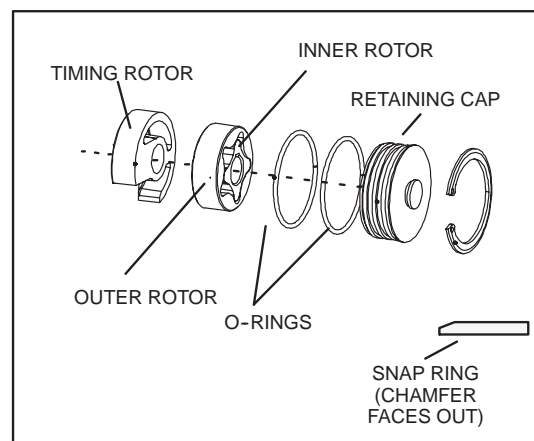

ENGINE DISASSEMBLY / ASSEMBLY

Oil Lubrication System Hose Routings

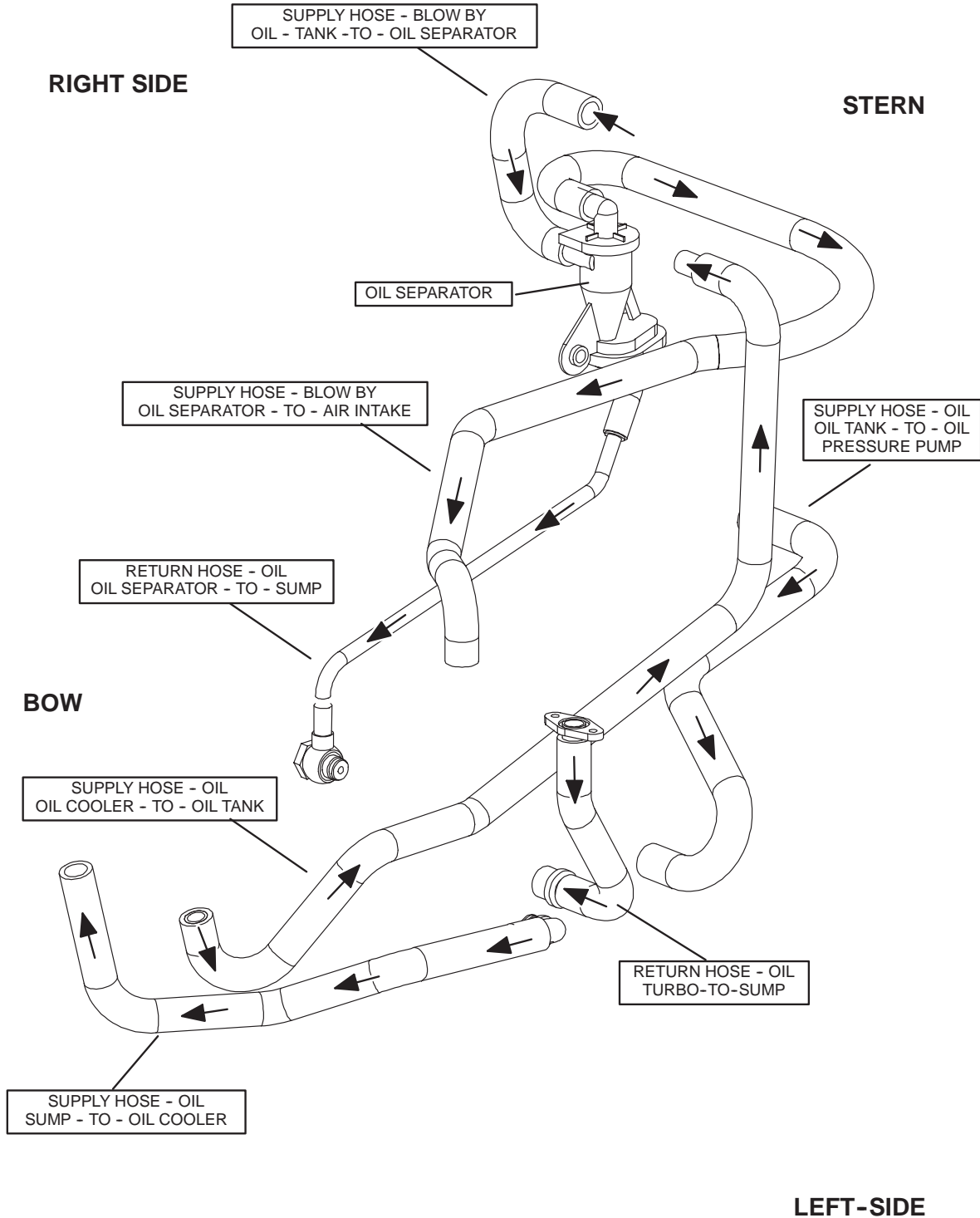

ENGINE DISASSEMBLY / ASSEMBLY

High Pressure Oil Supply

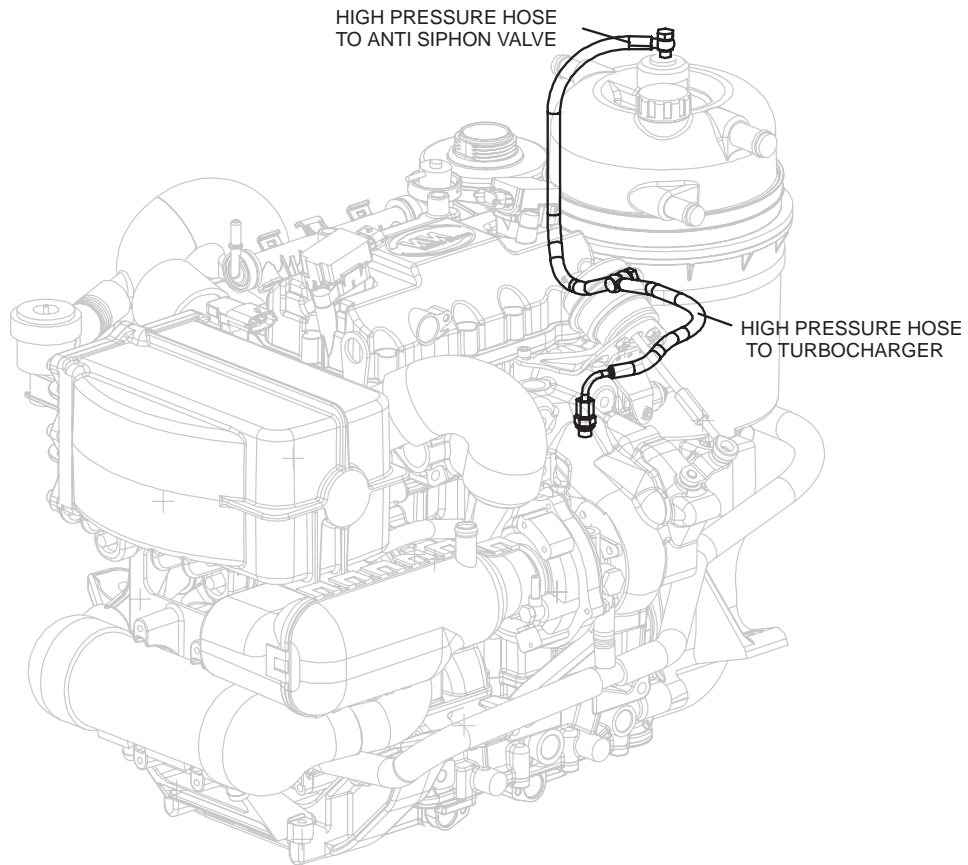

ENGINE DISASSEMBLY / ASSEMBLY

High Pressure Oil Supply

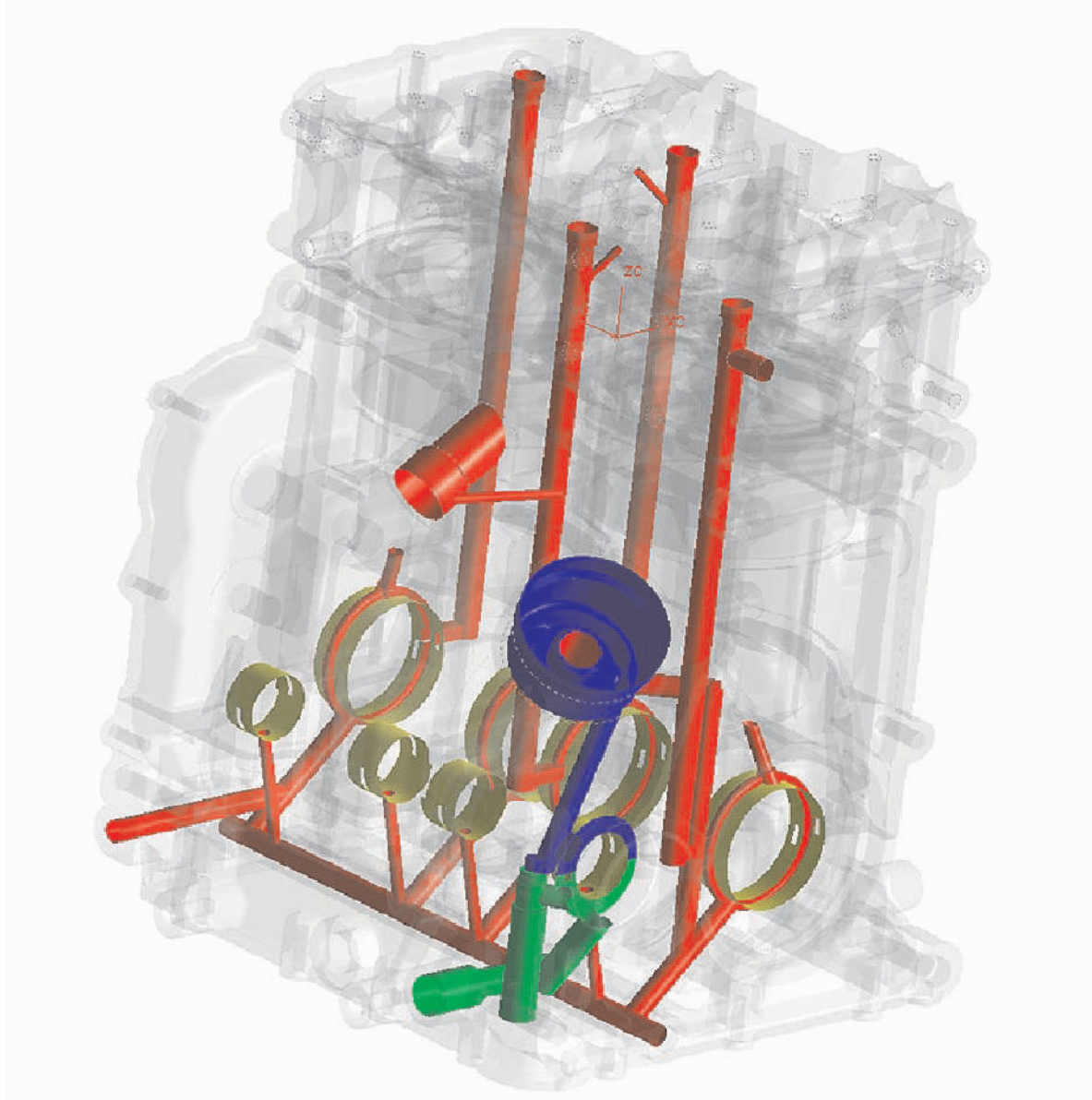

GREEN = LOW PRESSURE / PRE FILTRATION
BLUE = HIGH PRESSURE / PRE FILTRATION
RED = HIGH PRESSURE / POST FILTRATION



POLARIS[®]

WATERCRAFT

MSX 110 / 150 Service Manual

Fuel Injection / Ignition / Exhaust Systems

Bosch Engine Management System Overview	5.1
Engine Management System Specifications	5.2
Air Inlet Hose Routings	5.3
Fuel Hose Routings	5.4
Vent Hose Routing	5.5
Fuel Tank Assembly Illustration	5.6
Fuel Supply / Vent Hose Illustration	5.7
Fuel Rail / Injector Illustration	5.8
Electronic Throttle Body Illustration	5.9
Spark Plug / Ignition Coil Illustration	5.10
ECU Mounting Illustration	5.11
ECU Wiring Harness Connector Illustrations	5.12 - 5.14
Engine Management Sensor Circuit Drawings w/Trouble Codes	5.15 - 5.27
ECU Connectors	5.28
ECU Trouble Codes	5.29
Electronic Throttle Body / PPU Troubleshooting	5.30
Exhaust System Illustration	5.31
Turbocharger / Wastegate Overview	5.32 - 5.33
Charge Air Cooler Overview / Turbocharger Troubleshooting	5.34
RPM Limiting Modes	5.35
Troubleshooting: Engine Will Not Turnover	5.36
Troubleshooting: Engine Turns Over; Will Not Start	5.37
Troubleshooting: Engine Stalls; Will Re-Start	5.38
Troubleshooting: Engine Stalls: Will Not Re-Start	5.39
Troubleshooting: Engine Lacks Performance, RPM Limits	5.40 - 5.42
Troubleshooting: General	5.43

FUEL INJECTION / IGNITION / EXHAUST SYSTEMS

Bosch ME - Motronic 7.4.4 Engine Management System

The Bosch engine management system implements the engine's operational status in-line with the operator's demands. The microprocessor responds to this demand by translating the throttle flipper travel into a specified engine output.

The Engine Control Unit (ECU) is responsible for controlling and monitoring the density of each cylinders' air charges, the mass of injected fuel, and ignition timing.

In order to accomplish these tasks, the ECU relies on the following sensors and feedback systems:

- Throttle Flipper Position (PPU)
- Electronic Throttle Body Position (ETB)
- Lambda Sensor (O2 Sensor)
- Cam Phase Sensor
- Engine Speed Sensor (Crankshaft Position Sensor)
- Engine Coolant Sensor
- Knock Sensor
- Manifold Pressure Sensor
- Boost Pressure / Air Temp. Sensor
- Battery Voltage

The ECU has direct control over the following components:

- Fuel Injectors
- Ignition Coils
- Electronic Wastegate Solenoid
- Electronic Throttle Body DC Motor (ETB)
- Fuel Pump and Main Relay
- O2 Sensor Heating Element

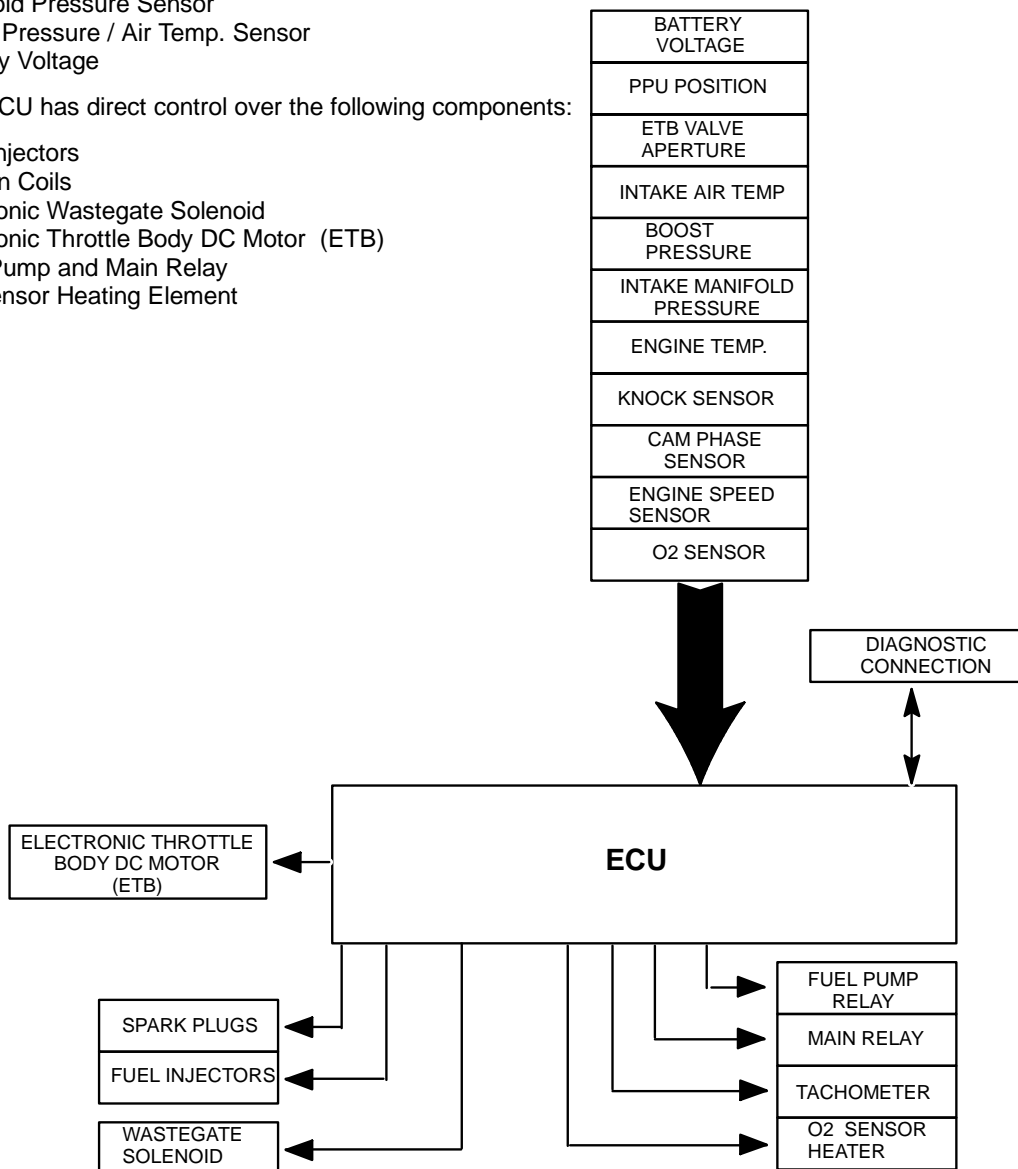

FUEL INJECTION / IGNITION / EXHAUST SYSTEMS

Fuel Injection and Ignition System Specifications

Component	Specification
Fuel Injection Type	Sequential Port Fuel Injection
Throttle Body Type	Electronic Throttle Body
Throttle Body Marking	Bosch DV-E5
ETB Throttle Position Sensor 1 Operating Voltage Range ETB Throttle Position Sensor 2 Operating Voltage Range (Range between lower and upper mechanical stop points.)	Tested Using Diagnostic Software .3 to .7 vDC @ LOWER MECHANICAL STOP 4.45 to 4.85 vDC @ UPPER MECHANICAL STOP Tested Using Diagnostic Software 4.3 to 4.7 vDC @ LOWER MECHANICAL STOP .15 to .55 vDC @ UPPER MECHANICAL STOP
PPU Position Sensor 1 Operating Voltage Range (0% to 80% OPEN) PPU Position Sensor 2 Operating Voltage Range (0% to 40% OPEN)	Tested Using Diagnostic Software .325 to .475 vDC @ 0% / 3.5 to 3.9 vDC @ 80% Tested Using Diagnostic Software .125 to .275 vDC @ 0% / 1.7 to 2.0 vDC @ 40%
Idle Speed In Water / Out of Water	1550 ± 50 RPM
Spark Plug Type	Champion RC7PYCB
Spark Plug Gap	.6 - .7mm (.025 - .030in.)
Fuel Pump Output Pressure	3 Bar + Boost (43.5 psi + Boost)
Fuel Pressure Regulator Type	Bosch DR 2.1
Ignition Coil Type	Bosch ZS-K-1
Primary Coil Resistance	.73Ω ± 10%
Secondary Coil Resistance	N/A - Diode Protected
Fuel Injector Type	Bosch EV-6E
Fuel Injector Resistance	12Ω
Engine Speed Sensor Resistance	860Ω ± 10% @ 68°F (20°C)
Engine Speed Sensor Gap	.8mm ± .5mm (.03 in. ± .02 in.)
Cam Phase Sensor Resistance	Tested Using Diagnostic Software
Cam Phase Sensor Gap	.8 mm (.03 in.)
TURBOCHARGER Type	3K Warner
Intercooler Type	Freshwater Cooled Charge Air Cooler
Maximum Boost Pressure MSX 110 MSX 150	[.75 BAR (10.8 PSI) GAUGE] / 1750 MB ABSOLUTE [1.1 BAR (16 PSI) GAUGE] / 2100 MB ABSOLUTE
OVERBOOST CONDITION MSX 110 MSX 150	[.8 - .9 BAR (11.6 - 13 psi for more than 400ms.) GAUGE] [1800 - 1900 MB ABSOLUTE] [1.3 BAR (18 psi) for more than 400ms. GAUGE] [2300 MB ABSOLUTE]
Wastegate Solenoid Resistance Tested Using Diagnostic Software	28.5 - 32Ω
Boost Pressure / Air Temp. Sensor Resistance	Tested Using Diagnostic Software
Manifold Pressure Sensor Resistance	Tested Using Diagnostic Software
Knock Sensor Resistance	4.9MΩ ± 20%
Engine Coolant Temperature Sensor Resistance	2.5KΩ ± 5% @ 68°F (20°C)
Exhaust Coolant Temperature Switch Resistance	1.4Ω
Oxygen Sensor Resistance between housing and ANY sensor pin. (New Condition @ 23°C / 50% humidity and heater off.) Resistance between heater and sensor signal circuit. (New Condition @ 23°C / 50% humidity and heater off.) @ 350°C exhaust temperature.	≥ 30MΩ ≥ 30MΩ (Between Pins 1 or 2 and Pin 3) ≥ 1MΩ

FUEL INJECTION / IGNITION / EXHAUST SYSTEMS

Air Inlet Hose Routings

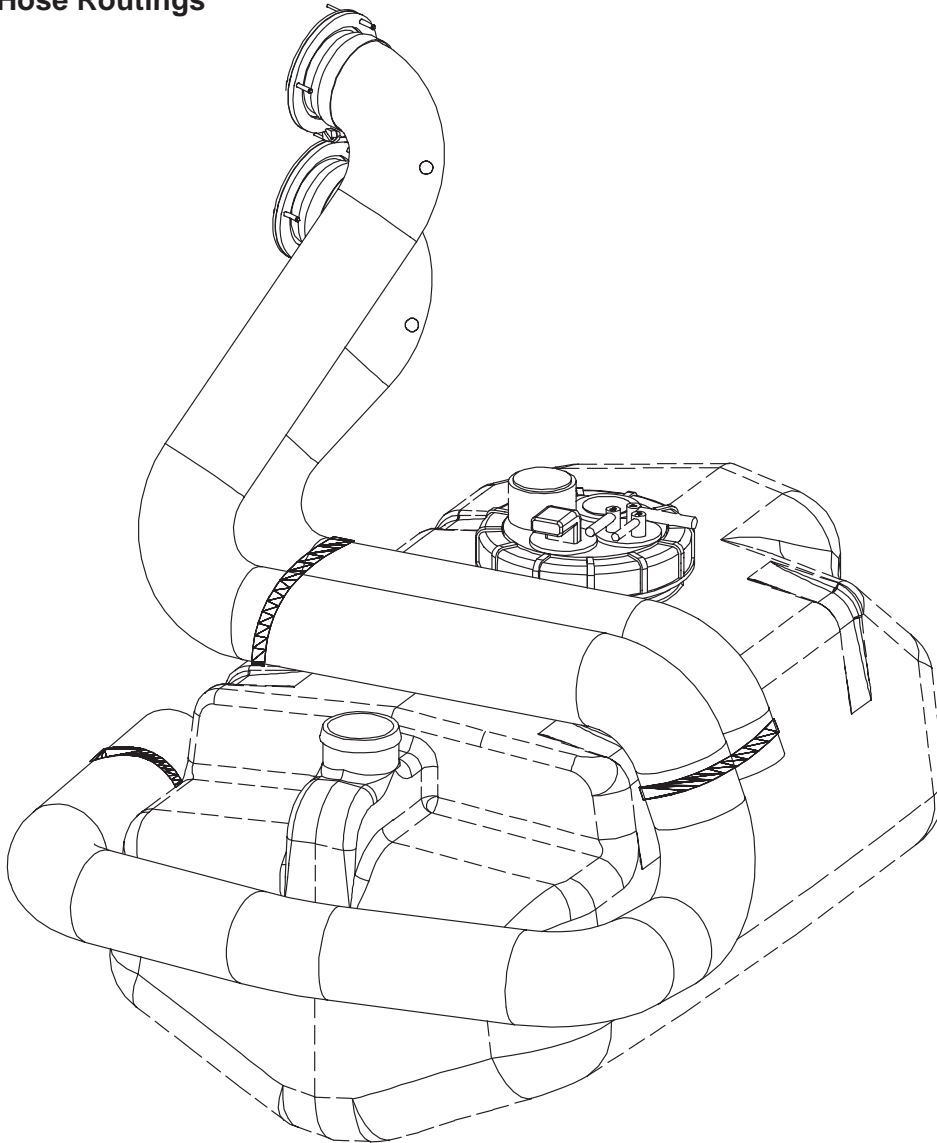

ASSEMBLY NOTES

Each air intake hose must be positioned as outlined in illustration.

FUEL INJECTION / IGNITION / EXHAUST SYSTEMS

Fuel Hose Routing

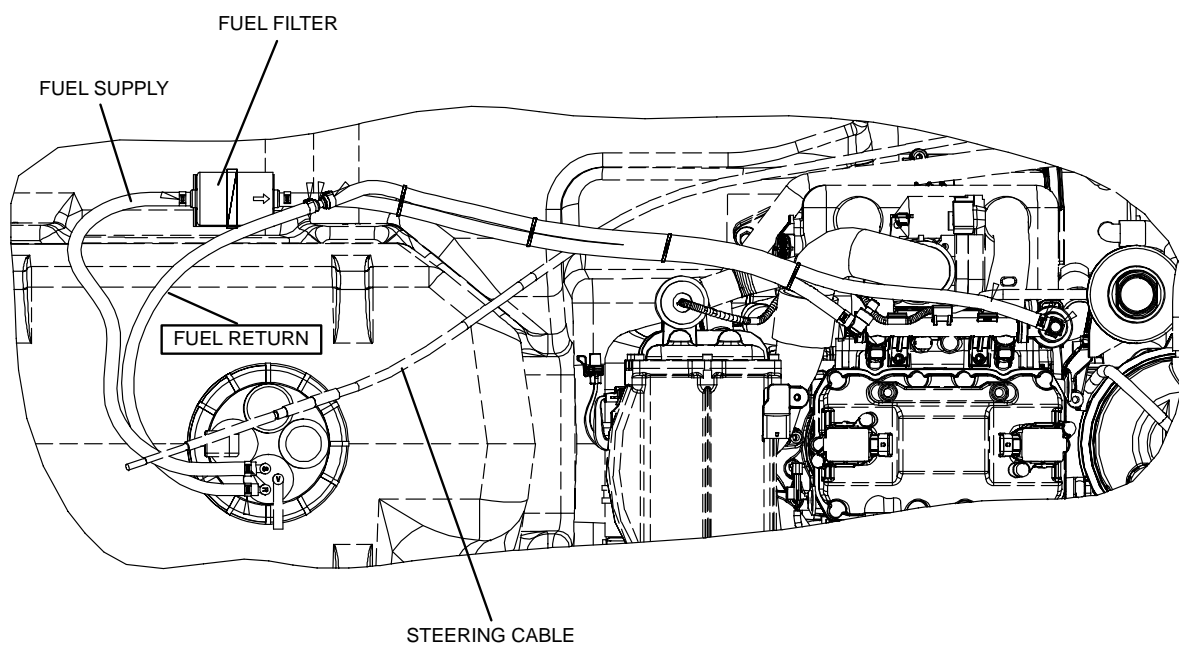

ASSEMBLY NOTES

Fuel supply hose is connected to "S" nozzle on fuel pump.

Fuel return hose is connected to "R" nozzle on fuel pump.

Fuel filter is connected to supply hose.

Both hoses are routed underneath steering cable at helm location.

Both hoses are routed over the steering cable at engine compartment location.

FUEL INJECTION / IGNITION / EXHAUST SYSTEMS

Vent Hose Routing

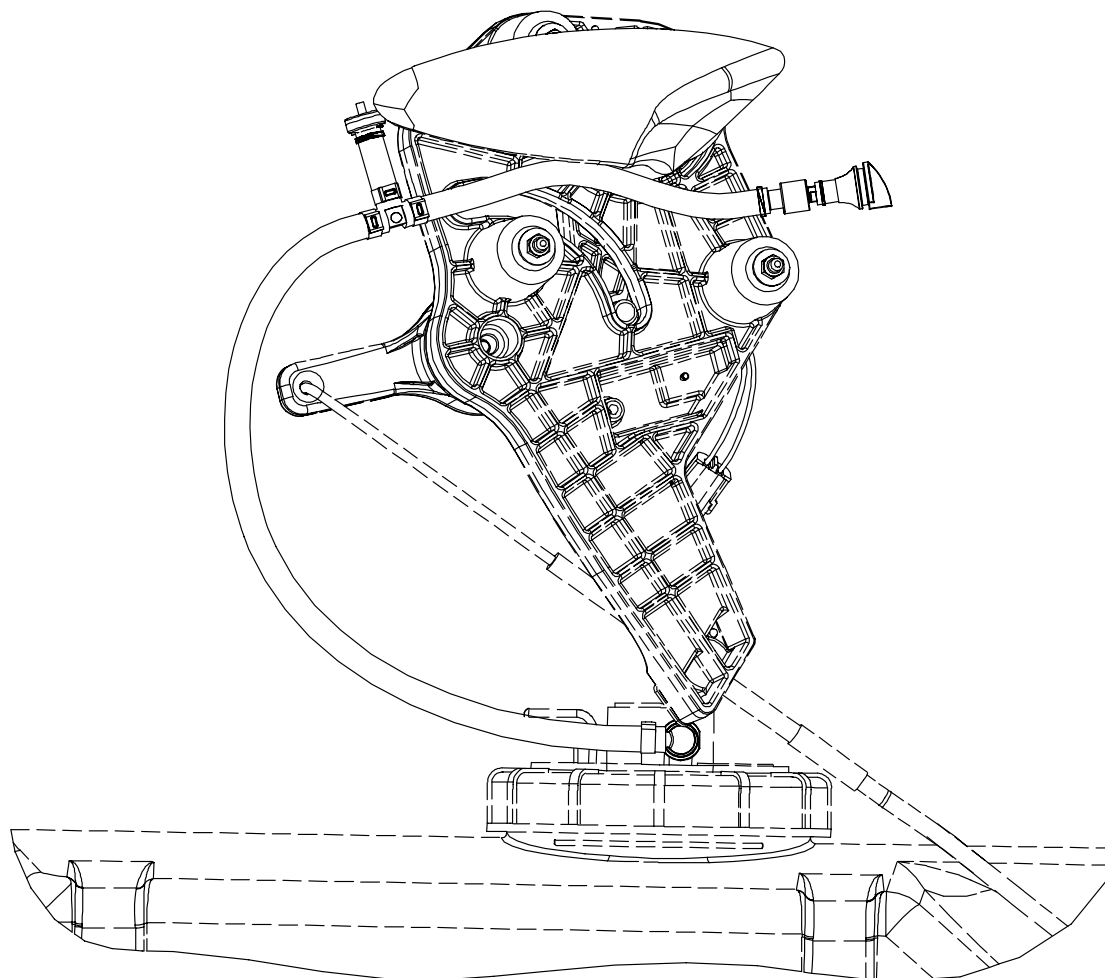

ASSEMBLY NOTES

Vent hose is connected to "V" nozzle on fuel pump.
Hose routed between reverse assembly and top deck.

FUEL INJECTION / IGNITION / EXHAUST SYSTEMS

Fuel Tank Assembly

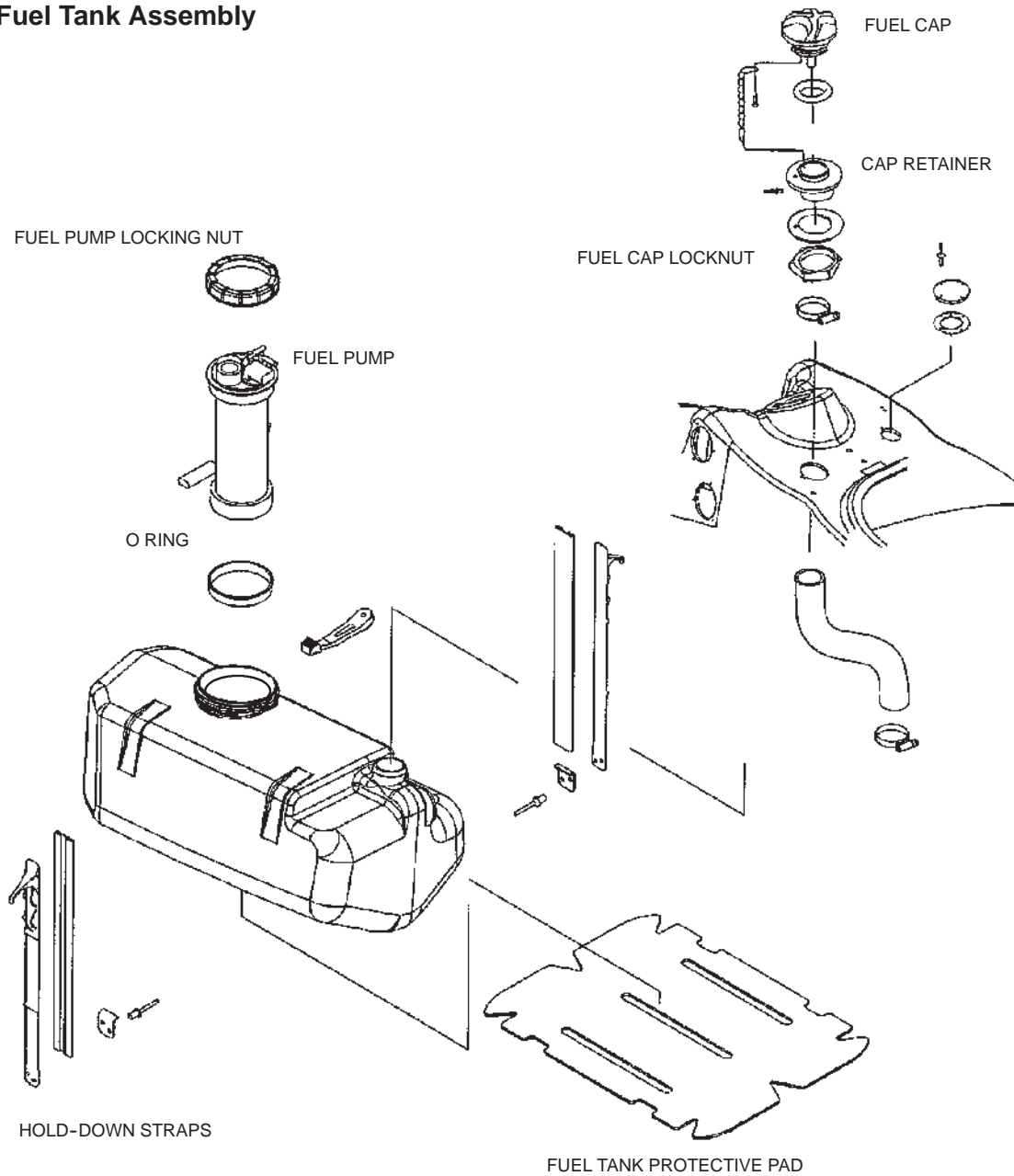

ASSEMBLY NOTES

Fuel Pump Nut Torque: 36 - 44 ft.lbs. (50 - 61 Nm)

Fuel Filler Nut Torque: 10 - 15 ft.lbs. (14 - 20 Nm)

Large Worm Gear Clamp Torque: 35 in.lbs. (4 Nm)

Verify tank pad is installed.

Replace tank hold-down straps if worn or damaged.

FUEL INJECTION / IGNITION / EXHAUST SYSTEMS

Fuel Supply / Vent Hoses

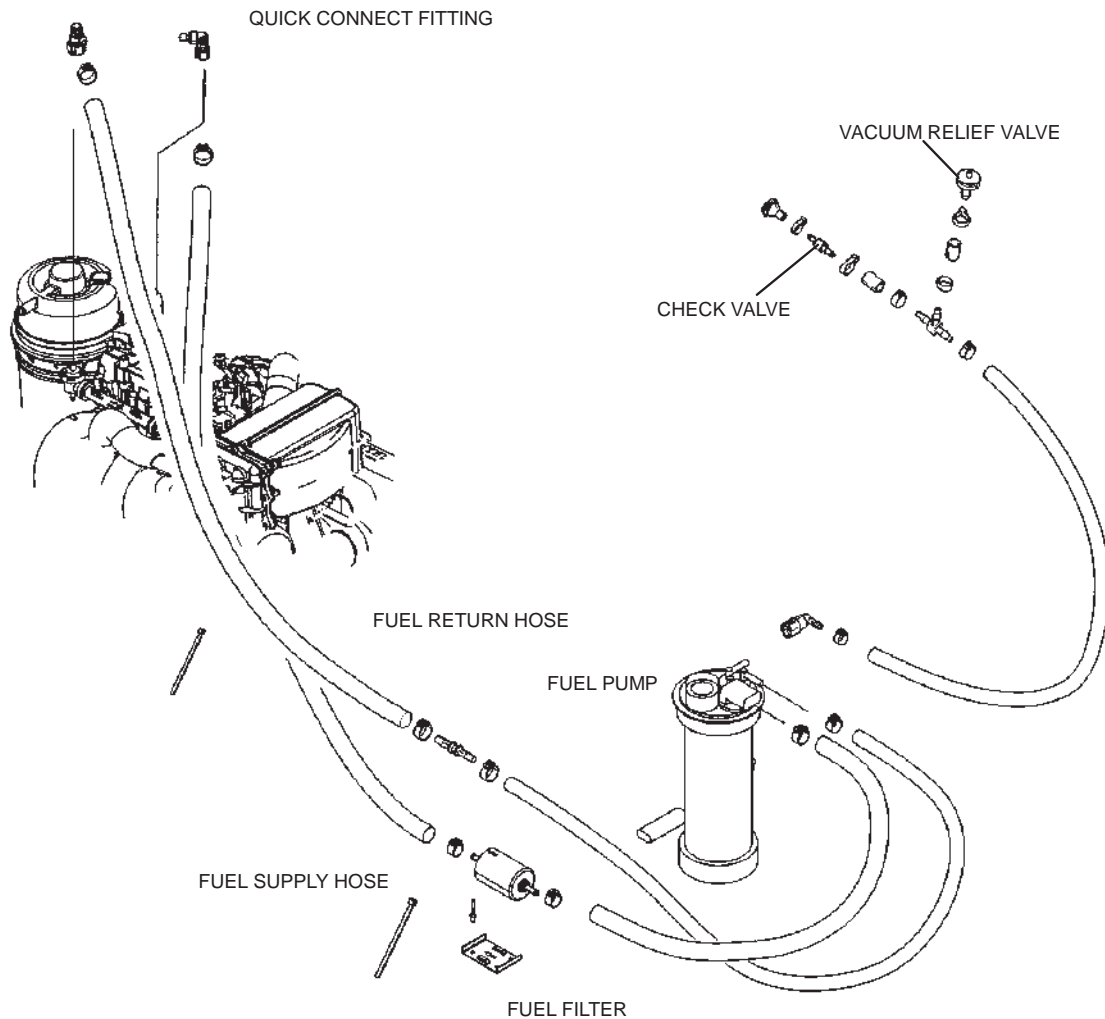

ASSEMBLY NOTES

Small Worm Gear Clamp Torque: 22 in.lbs. (2.5 Nm)

Fuel filter located on supply hose. Arrow on filter cartridge points downstream, towards fuel rail.

Verify hose routings are free from sharp bends and kinks. Never locate hoses near sharp objects.

Check valve opening pressure: 1.5 PSI.

Vacuum Relief Valve will allow air flow to pass when differential vacuum is equal to , or less than 3 HG.

FUEL INJECTION / IGNITION / EXHAUST SYSTEMS

Fuel Rail / Fuel injectors

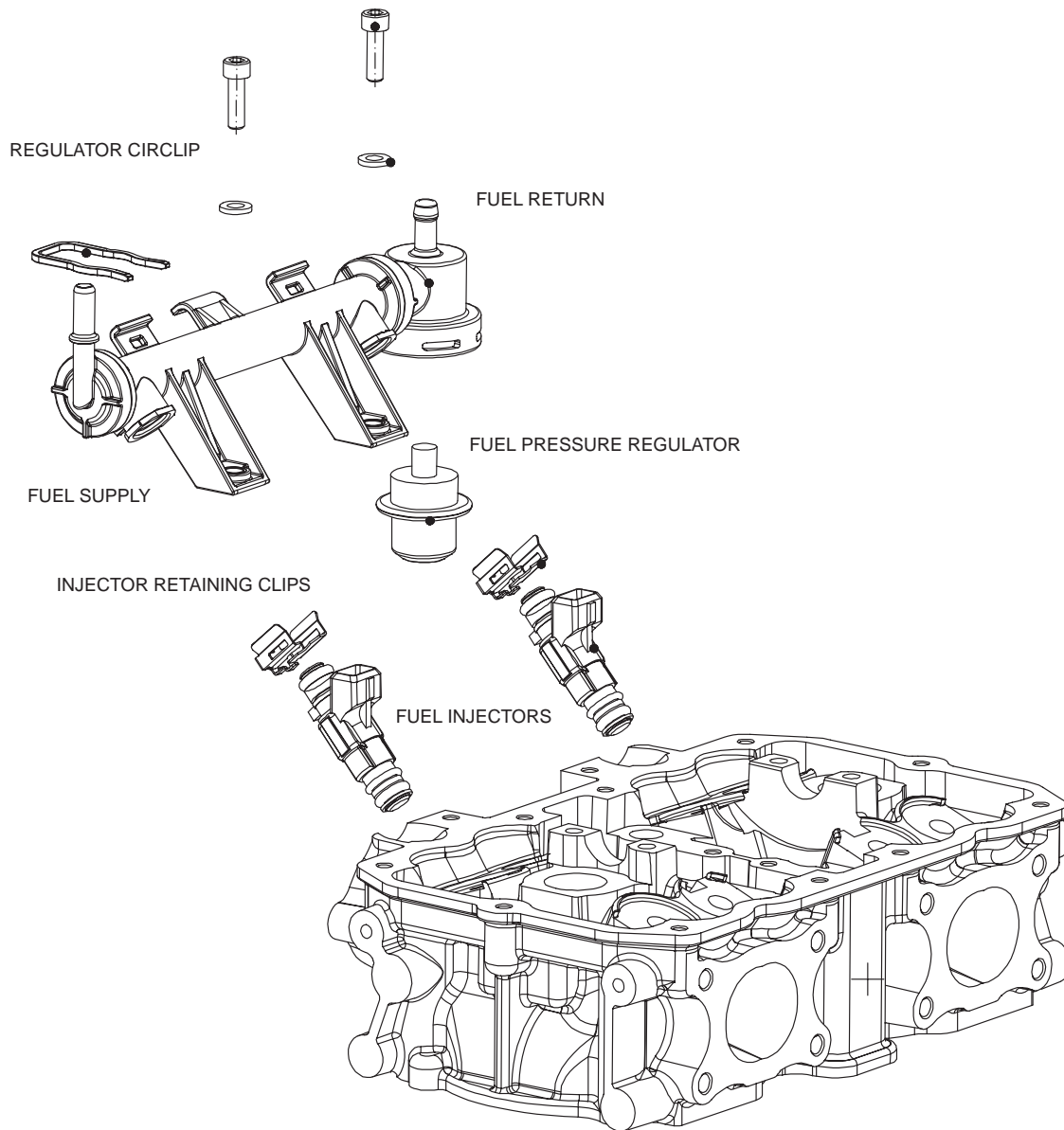

ASSEMBLY NOTES

Fuel Rail Fastener Torque: 7 ft.lbs. (10 Nm) DO NOT OVERTIGHTEN!

Use extreme care when removing fuel injectors from fuel rail.

Store removed fuel injectors in clean, dry place. Never allow foreign material to enter fuel injector screens.

Clean fuel injector nozzles and screens with clean fuel.

FUEL INJECTION / IGNITION / EXHAUST SYSTEMS

Electronic Throttle Body / Intake Manifold

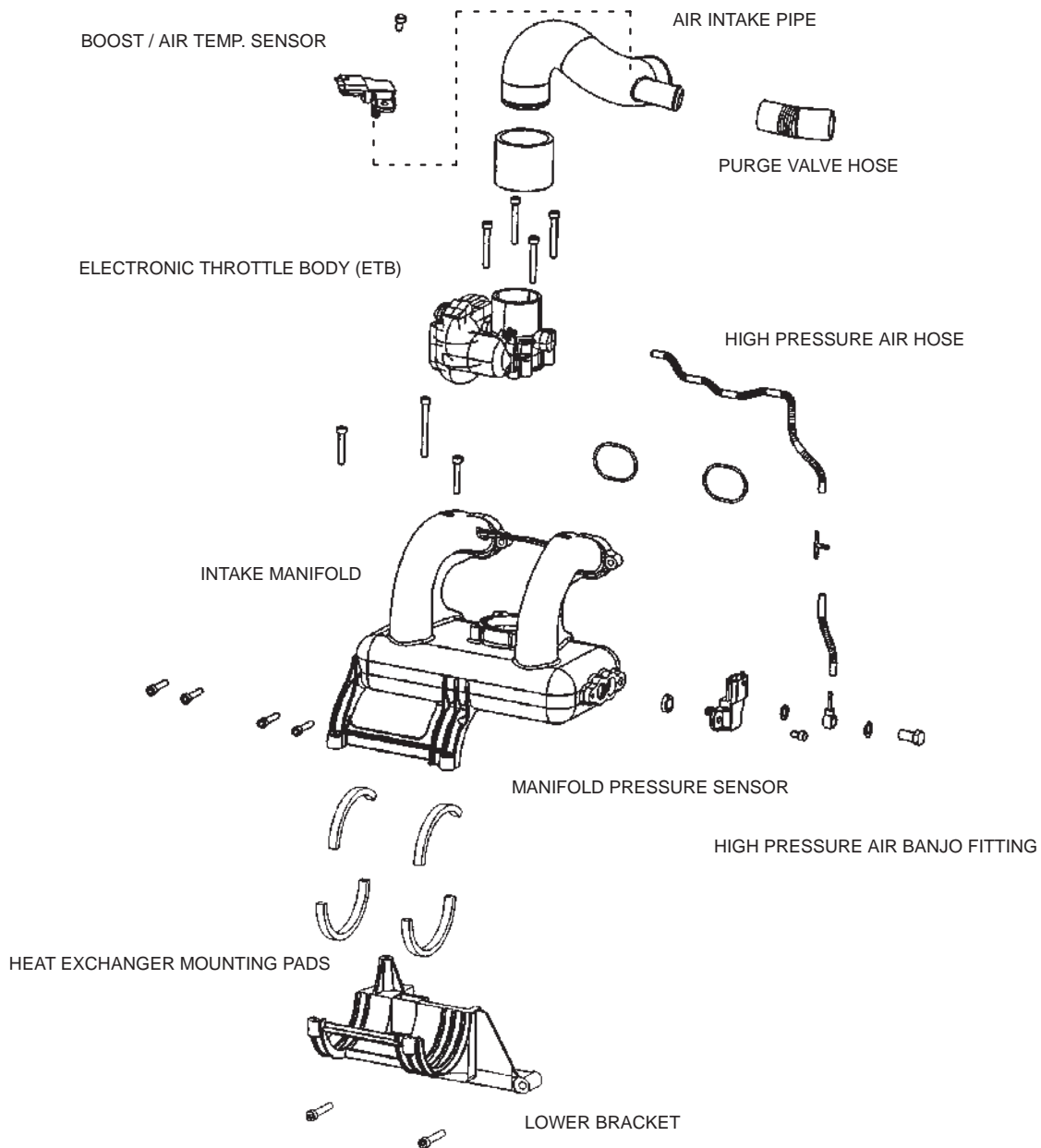

ASSEMBLY NOTES

Electronic Throttle Body Fasteners: 7 ft.lbs. (10 Nm)

Intake Manifold - To - Cylinder Head Fasteners: 7 ft.lbs. (10 Nm)

Manifold Pressure Sensor Fastener Torque: 5 ft.lbs. (7 Nm)

Manifold - To - Lower Bracket Fastener Torque: (M6 x 25): 7 ft.lbs. (10 Nm) / M8 x 60 17 ft.lbs. (24Nm) Apply Loctite™ 242 to threads.

Lower Bracket - To - Crankcase Fastener Torque: 22 ft.lbs. (30 Nm)

High Pressure Air Banjo Fitting Torque: 7 ft.lbs. (10 Nm)

Never re-use o-rings or gaskets.

Verify heat exchanger mount pads are installed.

FUEL INJECTION / IGNITION / EXHAUST SYSTEMS

Spark Plugs / Ignition Coils

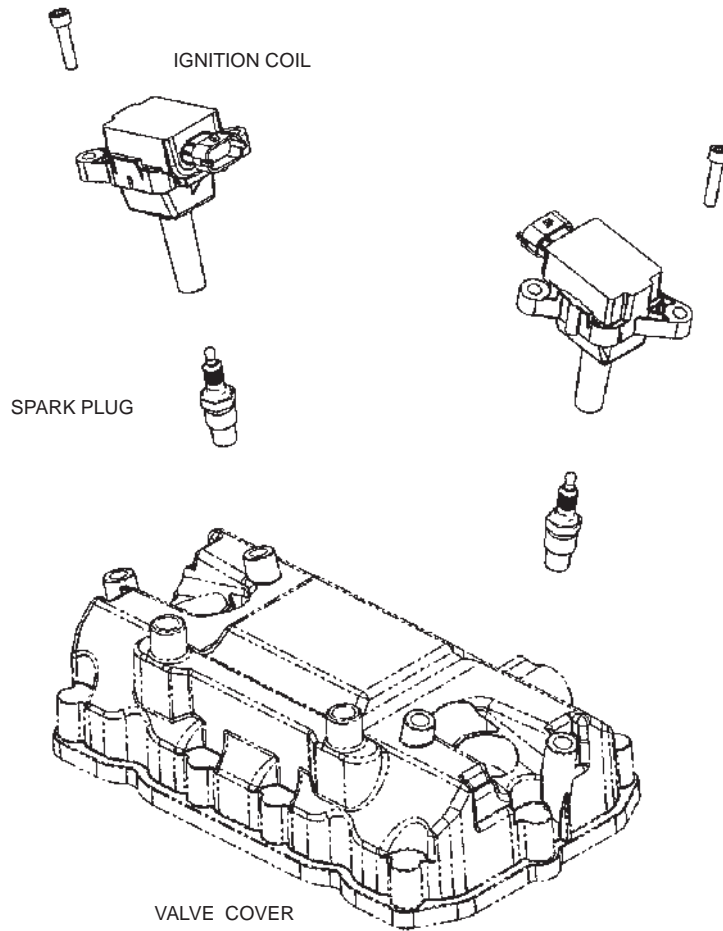

ASSEMBLY NOTES

Spark Plug Torque: 20 ft.lbs. (27 Nm) 7 ft.lbs. (10 Nm)

Ignition Coil Fastener Torque: 7 ft.lbs. (10 Nm)

Apply Nyogel™ to inside of spark plug cap during installation.

FUEL INJECTION / IGNITION / EXHAUST SYSTEMS

ECU Mounting

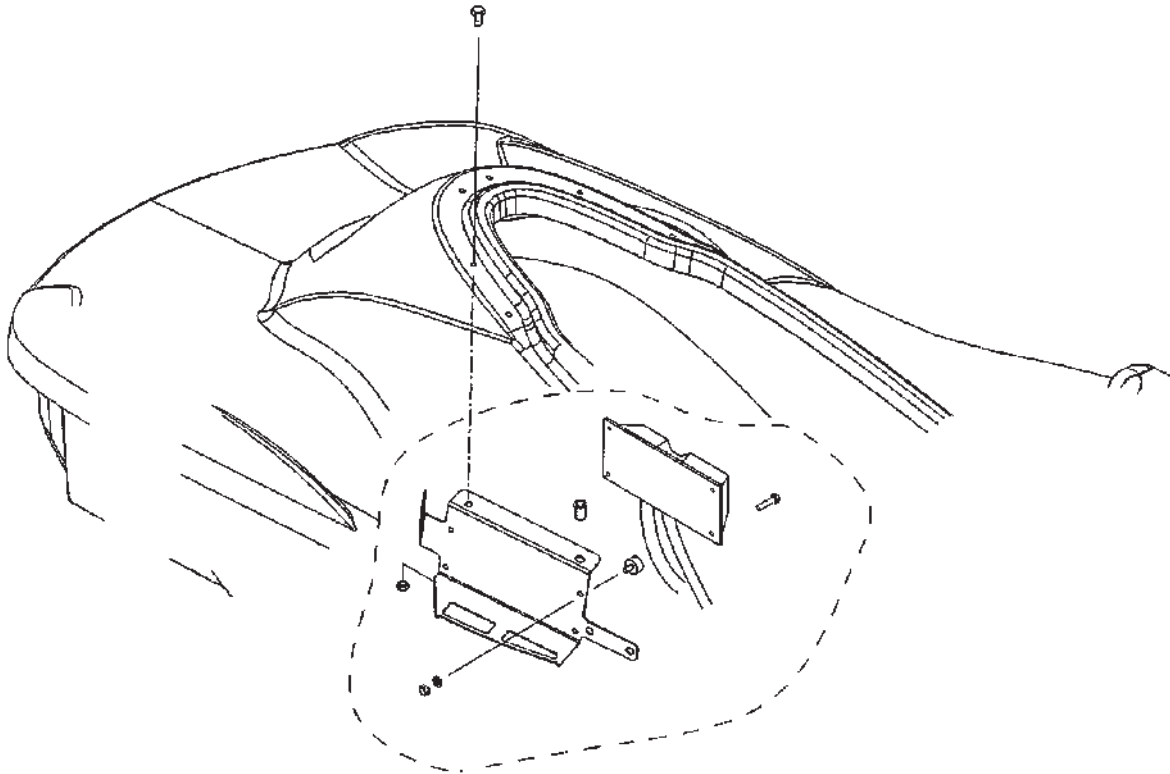

ASSEMBLY NOTES

ECU Mounting Bracket Fastener Torque: 10 ft.lbs. (13Nm)

ECU-To-Rubber Insulators: 24 in.lbs. (3 Nm)

ECU w/insulators-To-Mounting Bracket: 6 ft.lbs. (8Nm)

Starter Solenoid / Relay Fastener Torque: 6 ft.lbs. (8 Nm)

DO NOT APPLY NYOGEL™ TO THE STARTER SOLENOID CONNECTOR OR INSIDE OF CONNECTOR HOUSING.

FUEL INJECTION / IGNITION / EXHAUST SYSTEMS

ECU C100 Harness Connector (Grey Color Code)

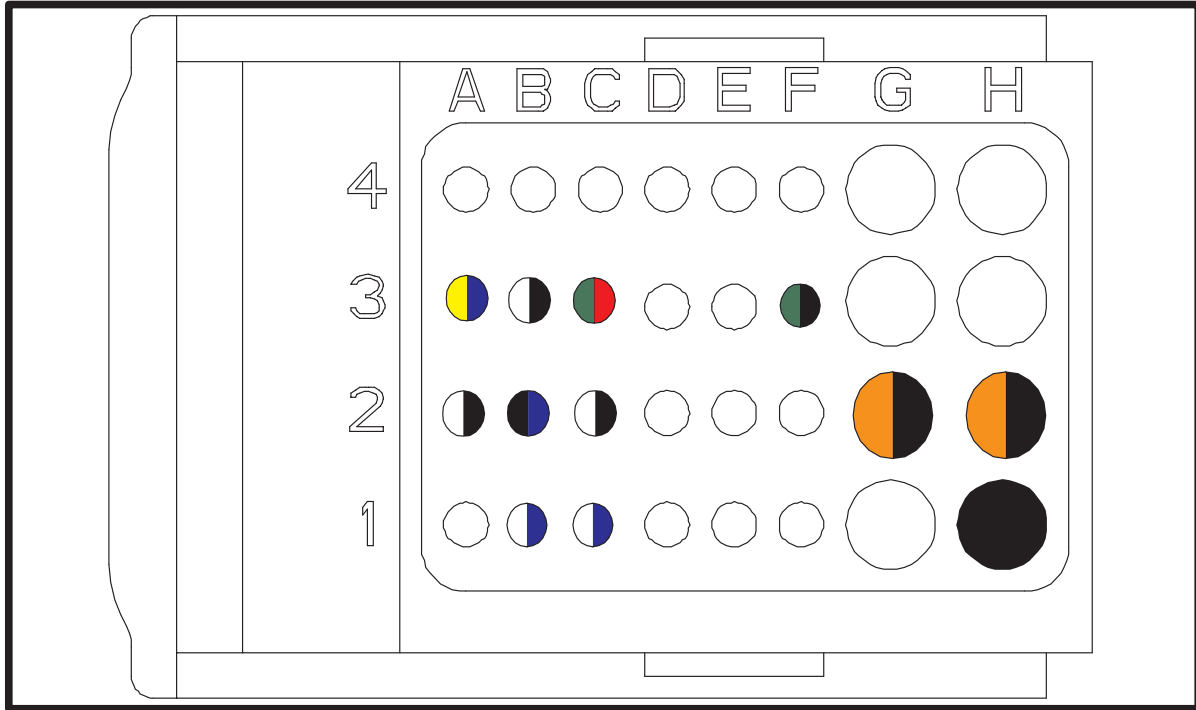

ECU C100 Harness Connector Interface Description (As viewed from terminal side.)

PIN	WIRE COLOR	PIN FUNCTION	SENSOR / SENSOR PIN #
H1	BLACK	Electronic Ground	Splice 8
C1	BLUE/WHT	Manifold Pressure Signal	Manifold Pressure Sensor / 4
B1	BLUE/WHT	Engine Speed Sensor Signal	Engine Speed Sensor / 1
H2	BLK/OR	Fuel Injector Output Signal	PTO Fuel Injector / 2
G2	BLK/OR	Fuel Injector Output Signal	MAG Fuel Injector / 2
C2	BLK/WHT	Sensor Reference Ground	(Splice 4) Manifold Pressure Sensor / 1 Boost Pressure Intake Temp. Sensor / 1
B2	BLU/BLK	Engine Speed Sensor Signal	Engine Speed Sensor / 2
A2	BLK/WHT	Sensor Reference Ground	Cam Phase Sensor / 1
F3	BLK/GRN	Fuel Pump Relay Signal	Main Relay / 7
C3	RED/GRN	5 Volt Reference Output Signal	(Splice 5) Cam Phase Sensor / 3 Manifold Pressure Sensor / 3 Boost Pressure - Intake Temp. Sensor / 3
B3	BLK/WHT	O2 Reference Ground	Lambda Sensor / 3
A3	BLU/YEL	O2 Signal Input	Lambda Sensor / 4

FUEL INJECTION / IGNITION / EXHAUST SYSTEMS

ECU C200 Harness Connector (Brown Color Code)

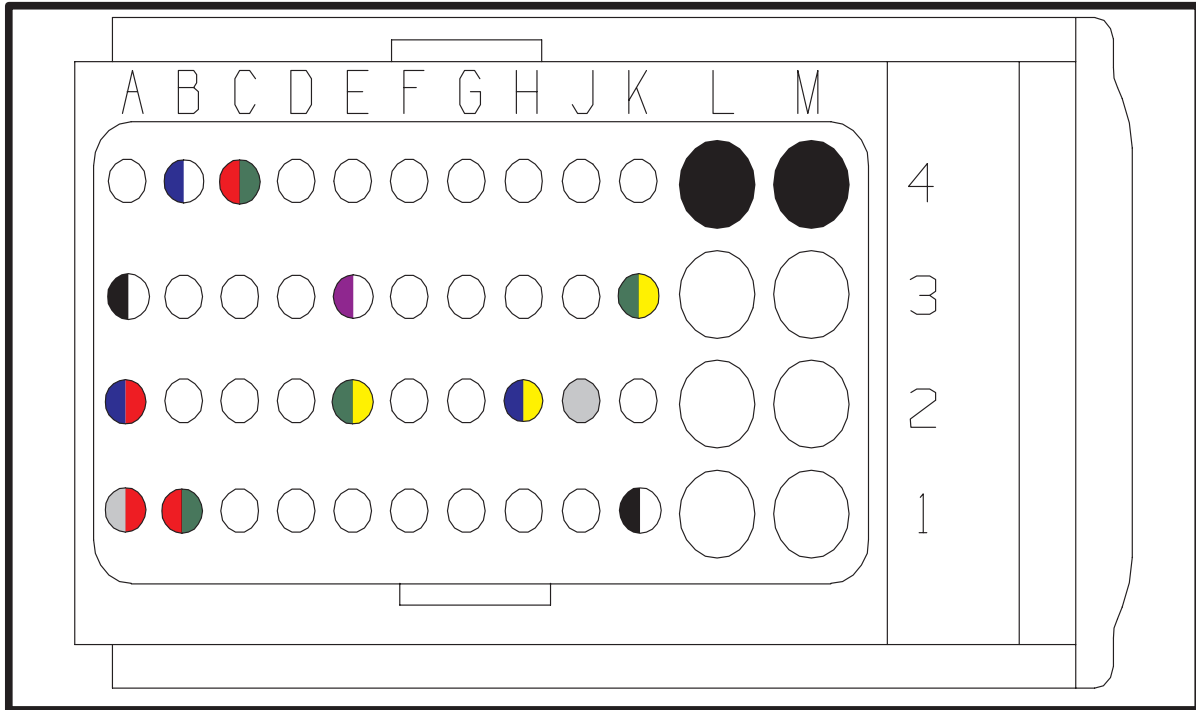

ECU C200 Harness Connector Interface Description (As viewed from terminal side.)

PIN	WIRE COLOR	PIN FUNCTION	SENSOR / SENSOR PIN #
B4	BLU/WHT	Ignition Switch Input	System Interface Box / C
C4	GRN/RED	Check Engine MIL Lamp	Engine - Chassis Connector / G
L4	BLACK	Electronic Ground	Splice 7
M4	BLACK	Fuel Injection Ground	Splice 8
A3	BLK/WHT	Engine Speed Sensor Ground	Engine Speed Sensor / 3
E3	PUR/WHT	ESP Signal Input	Engine - Chassis Connector / B
K3	GRN/YEL	Engine High Temp. MIL Output	Engine - Chassis Connector / H
A2	BLU/RED	Pedal Position 2 Input	PPU Interface Box / A
E2	GRN/YEL	Reverse Switch Signal Input	System Interface Box / B
H2	BLU/YEL	Diagnostic K-Line	Diagnostic Connector / A
J2	GREY	Engine Speed Signal (TACH.) Output	(Splice 12) System Interface Box / G Engine - Chassis Connector / K
A1	GRY/RED	Pedal Position 1 Input	PPU Interface Box / C
B1	RED/GRN	Pedal Position Supply Voltage	(Splice 11) Pedal Position Unit / 3, 6 PPU Interface Box / B
K1	BLK/WHT	Pedal Position Reference Ground	(Splice 10) Pedal Position Unit / 4, 5 PPU Interface Box / E

FUEL INJECTION / IGNITION / EXHAUST SYSTEMS

ECU C300 Harness Connector (Black Color Code)

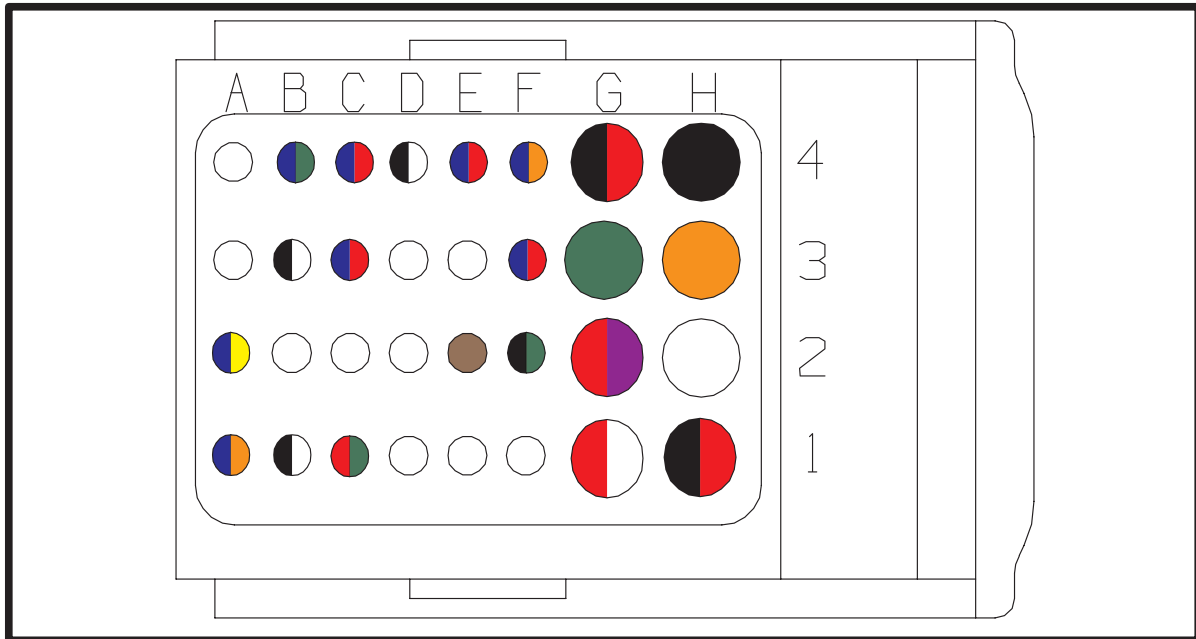

ECU C300 Harness Connector Interface Description (As viewed from terminal side.)

PIN	WIRE COLOR	PIN FUNCTION	SENSOR / SENSOR PIN #
B4	BLU/GRN	Throttle Position 2	Electronic Throttle Body / 5
C4	BLU/RED	Temp. Switch Input	Temp. Switch / A
D4	BLK/WHT	Sensor Reference Ground	Engine Temp. Sensor / 2
E4	BLU/RED	Engine Temp. Signal Input	Engine Temp. Sensor / 1
F4	BLU/OR	Boost Pressure Signal	Boost Pressure - Intake Temp. Sensor / 4
G4	BLK/RED	Sensor Reference Ground	Wastegate Solenoid / 1
H4	BLACK	Ignition Ground	(Splice 6) Ignition Coils / 2
B3	BLK/WHT	Knock Sensor Ground	Knock Sensor / 2
C3	BLU/RED	Knock Sensor Signal	Knock Sensor / 1
F3	BLU/RED	Cam Phase Sensor Signal	Cam Phase Sensor / 2
G3	GREEN	Ignition Driver 1	PTO Ignition Primary / 1
H3	ORANGE	Ignition Driver 2	MAG Ignition Primary / 1
A2	BLU/YEL	Intake Air Temp. Signal	Boost Pressure - Intake Temp. Sensor / 2
E2	BROWN	O2 Heating Supply	Lambda Sensor / 2
F2	BLK/GRN	Main Relay Output	Main Relay / 10
G2	RED/PUR	Switched Battery Supply Input	Main Relay / 2
A1	BLU/OR	Throttle Position 1 Input	Electronic Throttle Body / 6
B1	BLK/WHT	Throttle Position Ref. Ground	Electronic Throttle Body / 2
C1	RED/GRN	Throttle Position Supply Voltage	Electronic Throttle Body / 3
G1	RED/WHT	Throttle Plate Positive Voltage	Electronic Throttle Body / 4
H1	BLK/RED	Throttle Plate Negative Voltage	Electronic Throttle Body / 1

FUEL INJECTION / IGNITION / EXHAUST SYSTEMS

Electronic Throttle Body Circuit

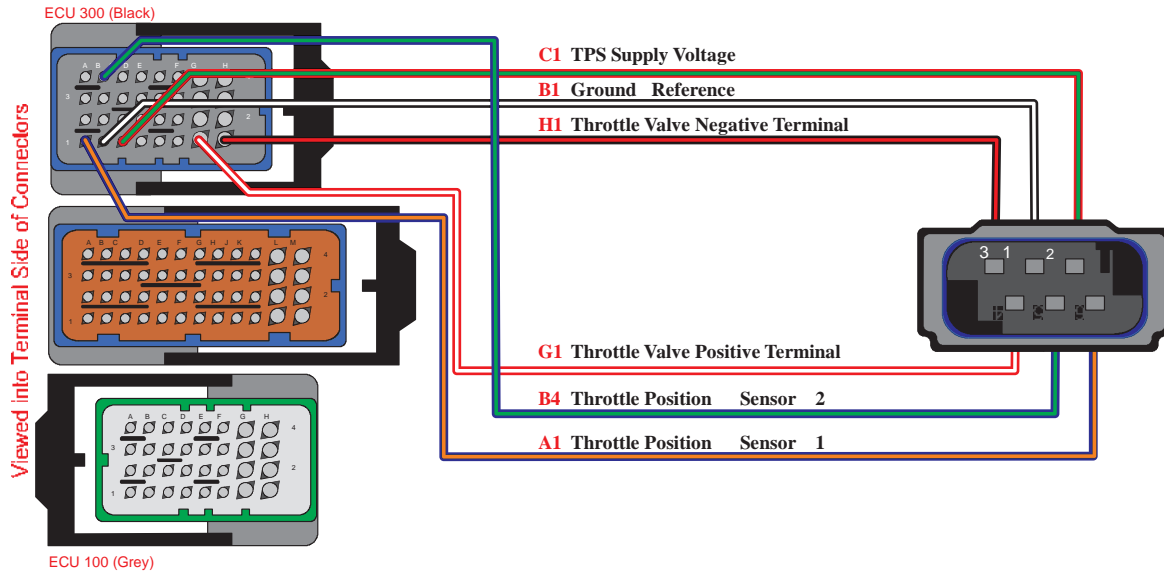

Circuit Trouble Codes

P - Code	Description	Summary
P0120	Throttle Position Sensor: Plausibility Error	Indicates the readings from the two TPS sensors do not agree.
P0122	Throttle Position Sensor: Open or Short to Ground	Indicates an open, or short to ground condition in one of the TPS signal circuits.
P0123	Throttle Position Sensor: Short to Battery	Indicates a short to battery voltage condition in one of the TPS signal circuits.
P1601	Throttle Valve Learning: Position Out of Range	Indicates the low mechanical position during learning was out of range.
P1602	Throttle Valve Learning: Conditions Not Met	Indicates environmental conditions during learning were out of range.
P1603	Throttle Valve Learning: Signal Error	Indicates the throttle valve was not able to move far enough to complete the learning process.
P1604	Throttle Valve Learning: Battery Voltage Too Low	Battery voltage was too low to complete the learning process.
P1900	Throttle Valve Servo: Plausibility Error	The throttle valve servo is unable to reach the desired throttle valve opening.
P1901	Throttle Valve Servo: Setting Out of Range (Low)	The throttle valve servo is unable to reach the desired throttle valve opening.
P1902	Throttle Valve Servo: Setting Out of Range (High)	The throttle valve servo is unable to reach the desired throttle valve opening.
P1903	Throttle Valve Servo: Signal Error	The throttle valve servo is unable to reach the desired throttle valve opening.

FUEL INJECTION / IGNITION / EXHAUST SYSTEMS

Pedal Position (PPU) Circuit

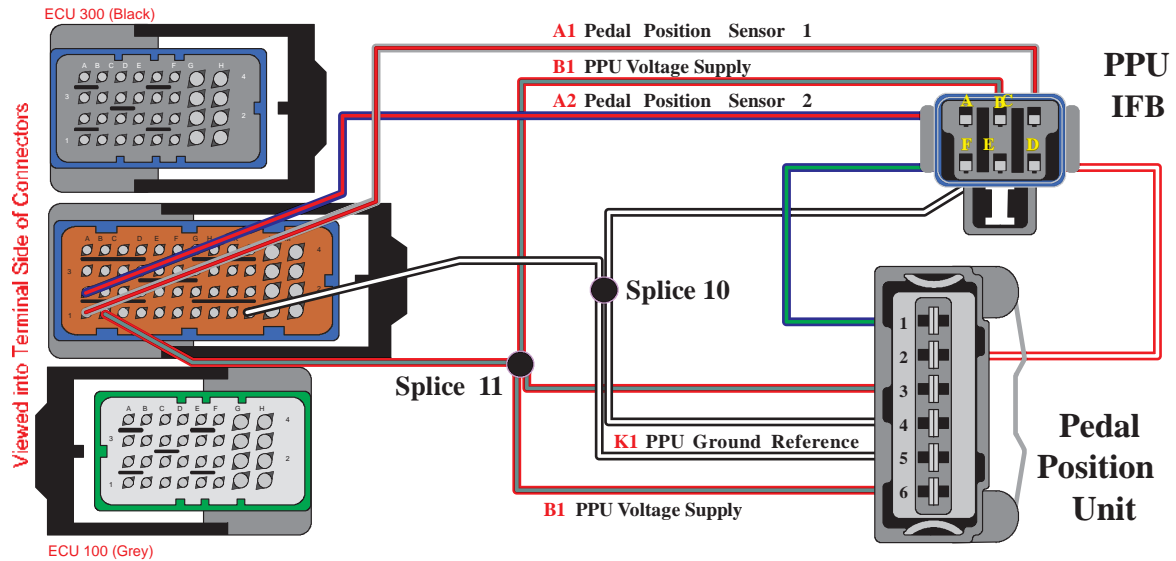

Circuit Trouble Codes

P - Code	Description	Summary
P0220	Pedal Position Sensor #1: Plausibility Error	Indicates the signals from the two pedal position sensors do not agree.
P0222	Pedal Position Sensor #1: Short to Ground	Pedal position sensor # 1 signal is too low. Can be caused by a short to ground in the pedal position sensor #1 circuit.
P0223	Pedal Position Sensor #1: Open or Short to Battery	Pedal position sensor #1 signal is too high. Can be caused by a open circuit or short to battery voltage.
P0225	Pedal Position Sensor #2: Plausibility Error	Indicates the signals from the two pedal position sensors do not agree.
P0227	Pedal Position Sensor #2: Short to Ground	Pedal position sensor #2 signal is too low. Can be caused by a short to ground in the pedal position sensor #2 circuit.
P0228	Pedal Position Sensor #2: Open or Short to Battery	Pedal position sensor #2 signal is too high. Can be caused by a open circuit or short to battery voltage.

FUEL INJECTION / IGNITION / EXHAUST SYSTEMS

Fuel Injection Circuit

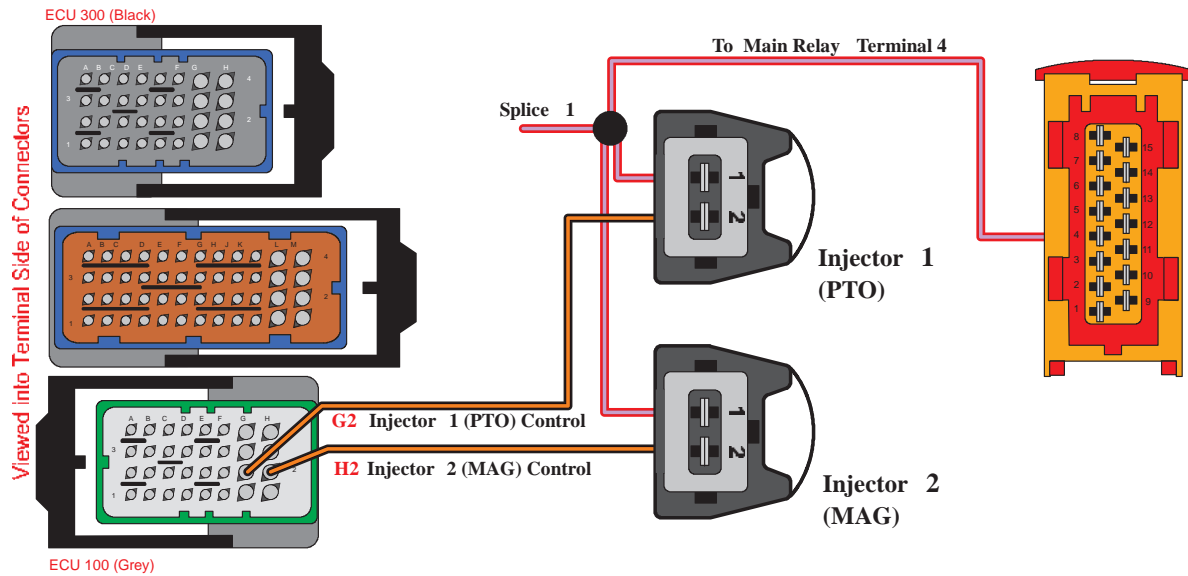

Circuit Trouble Codes

P - Code	Description	Summary
P0261	Injector #1: Short to Ground	Fuel injector #1 driver circuit is shorted to ground. Operating the engine with this code can cause serious engine damage.
P0262	Injector #1: Short to Battery	Fuel injector #1 circuit is shorted to battery voltage.
P0264	Injector #2: Short to Ground	Fuel injector #2 driver circuit is shorted to ground. Operating the engine with this code can cause serious engine damage.
P0265	Injector #2: Short to Battery	Fuel injector #2 circuit is shorted to battery voltage.
P1260	Injector #1: Open Load	The #1 fuel injector circuit is open.
P1263	Injector #2: Open Load	The #2 fuel injector circuit is open.

FUEL INJECTION / IGNITION / EXHAUST SYSTEMS

Ignition Coil Circuit

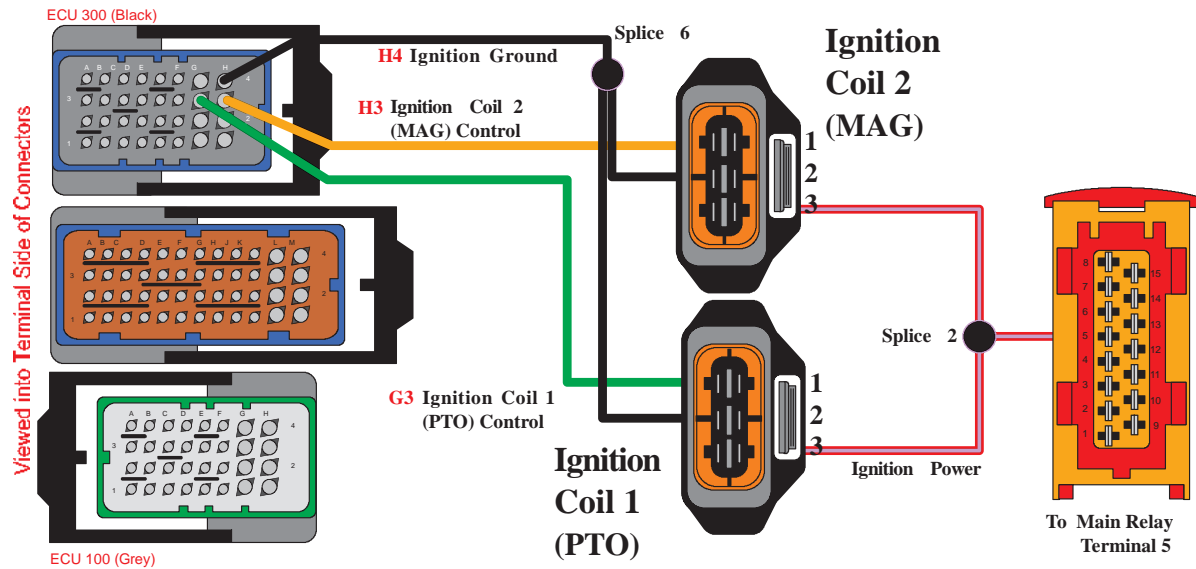

Circuit Trouble Codes

P - Code	Description	Summary
P0351	Ignition Coil #1: Plausibility Error	Both ignition coil circuits are shorted to ground.
P0352	Ignition Coil #2: Plausibility Error	Both ignition coil circuits are shorted to ground.
P1351	Ignition Coil #2: Short to Ground	Ignition coil #2 circuit is shorted to ground.
P1352	Ignition Coil #1: Short to Ground	Ignition coil #1 circuit is shorted to ground.
P1353	Ignition Coil #2: Short to Battery	Ignition coil #2 circuit is shorted to battery voltage.
P1354	Ignition Coil #1: Short to Battery	Ignition coil #1 circuit is shorted to battery voltage.

FUEL INJECTION / IGNITION / EXHAUST SYSTEMS

Lambda Sensor Circuit

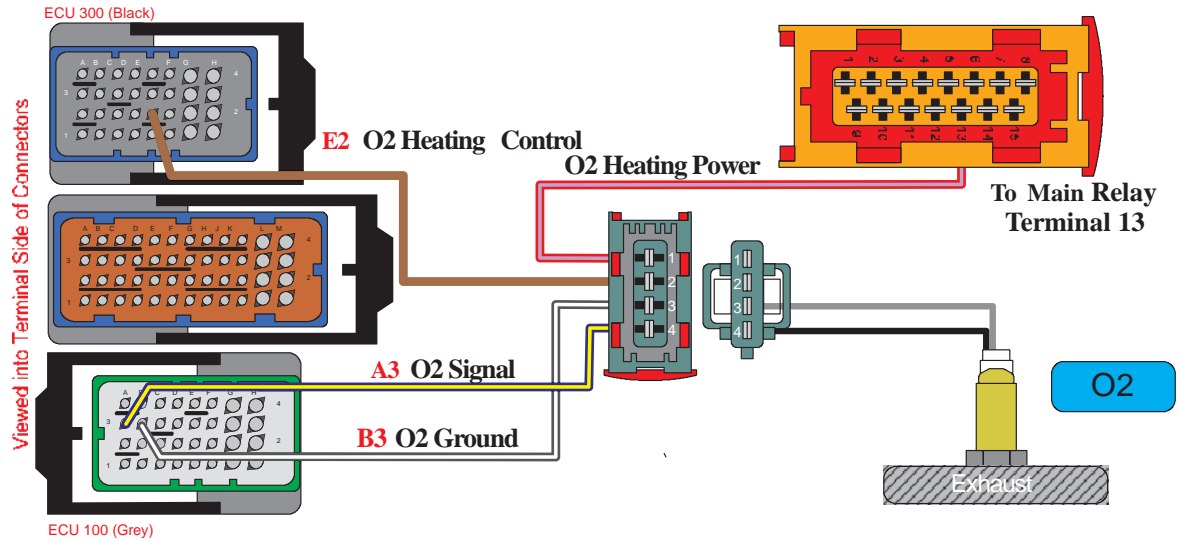

Circuit Trouble Codes

P - Code	Description	Summary
P0030	Heated Oxygen Sensor Circuit: Open Load	The O2 heater circuit is open.
P0031	Heated Oxygen Sensor Circuit: Short to Ground	The O2 heater circuit is shorted to ground.
P0032	Heated Oxygen Sensor Circuit: Short to Battery	The O2 heater circuit is shorted to battery voltage.
P0130	Oxygen Sensor Circuit: Signal Error	TBD
P0131	Oxygen Sensor Circuit: Plausibility Error	Indicates the O2 sensor signal is outside an acceptable range.
P0132	Oxygen Sensor Circuit: Short to Battery	Indicates the O2 sensor signal is too high.
P0133	Oxygen Sensor Circuit: Slow Response	The O2 sensor signal is slow to respond to fuel mixture changes.
P0134	Oxygen Sensor Circuit: Low Output	The O2 sensor signal has not changed for a long period of time.
P0135	Heated Oxygen Sensor Circuit: Plausibility Error	The O2 sensor signal is outside an acceptable range.

FUEL INJECTION / IGNITION / EXHAUST SYSTEMS

Boost / Air Temperature Circuit

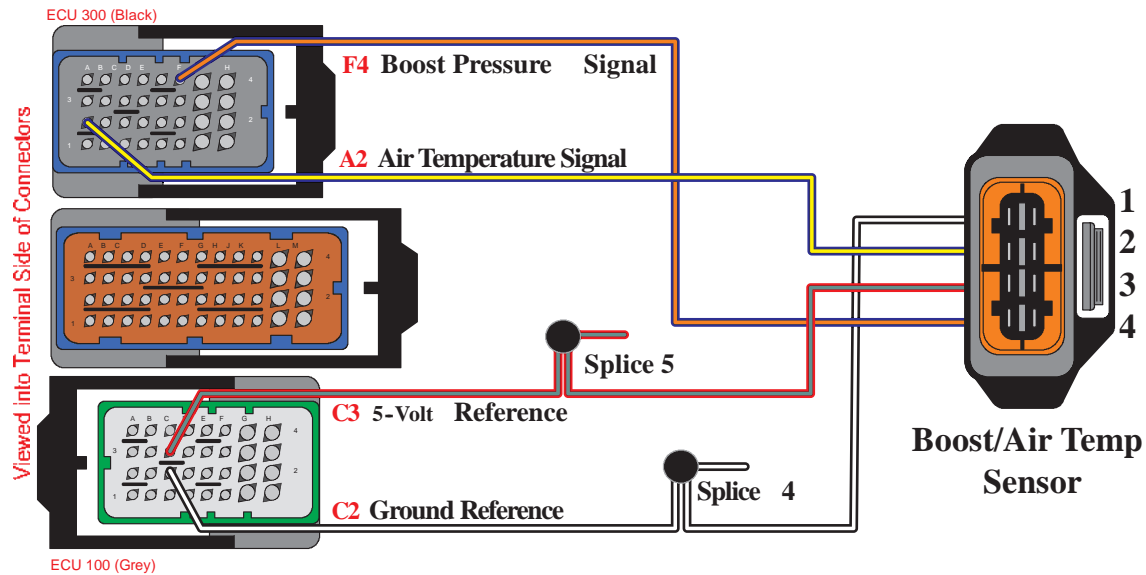

Circuit Trouble Codes

P - Code	Description	Summary
P0112	Intake Air Temperature: Short to Ground	The intake air temp. signal is shorted to ground or open.
P0113	Intake Air Temperature: Short to Battery	The intake air temp. signal is shorted to battery voltage.
P0237	Boost Pressure Sensor: Open or Short to Ground	The boost pressure signal is shorted to ground or open.
P0238	Boost Pressure Sensor: Short to Battery	The boost pressure signal is shorted to battery voltage.

FUEL INJECTION / IGNITION / EXHAUST SYSTEMS

Manifold Pressure Circuit

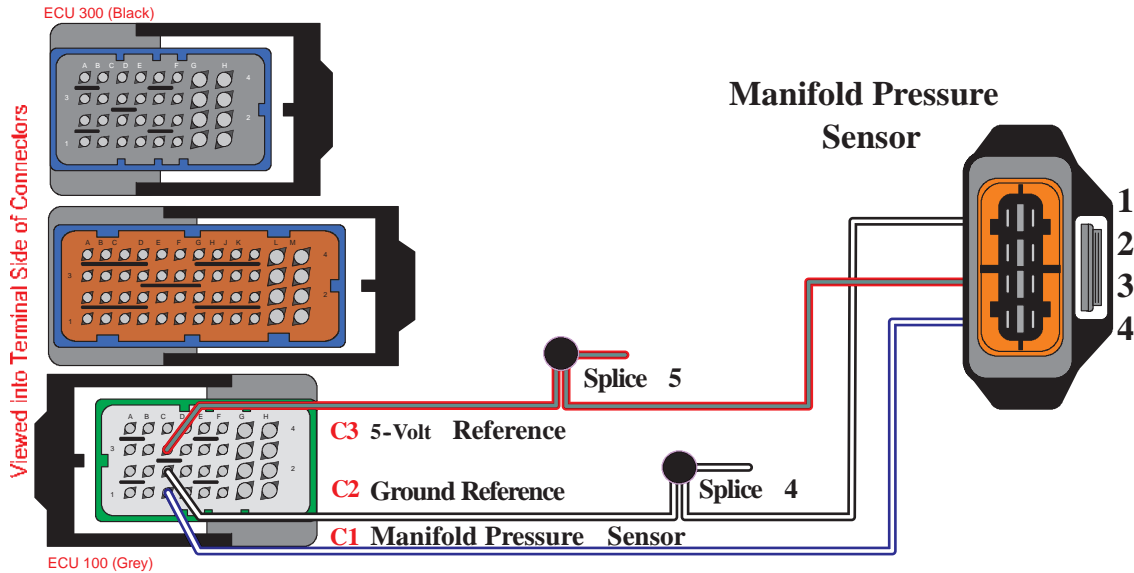

Circuit Trouble Codes

P - Code	Description	Summary
P0105	Intake Manifold Pressure: Plausibility Error	The measured intake manifold pressure is outside an acceptable range.
P0106	Intake Manifold Pressure: Signal Error	the intake manifold pressure is outside an acceptable range, but not shorted to ground or battery voltage.
P0107	Intake Manifold Pressure: Short to Ground	The intake manifold pressure signal is shorted to ground.
P0108	Intake Manifold Pressure: Short to Battery	The intake manifold pressure signal is shorted to battery voltage.

FUEL INJECTION / IGNITION / EXHAUST SYSTEMS

Engine Coolant Temperature Sensor Circuit

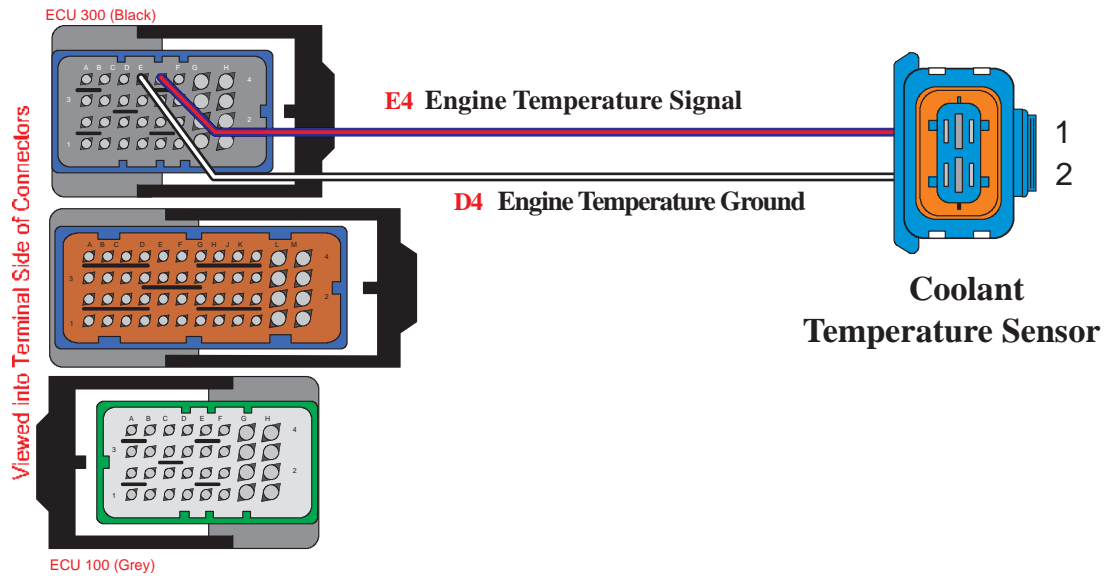

Circuit Trouble Codes

P - Code	Description	Summary
P0116	Engine Temperature: Signal Error	Indicates the engine temp. signal is outside an acceptable range, but not shorted to ground or battery voltage.
P0117	Engine Temperature: Short to Ground	The engine temp. signal is shorted to ground.
P0118	Engine Temperature: Open or Short to Battery	The engine temp. signal is shorted to battery voltage.

FUEL INJECTION / IGNITION / EXHAUST SYSTEMS

Engine Crankshaft Position (Engine Speed) Sensor Circuit

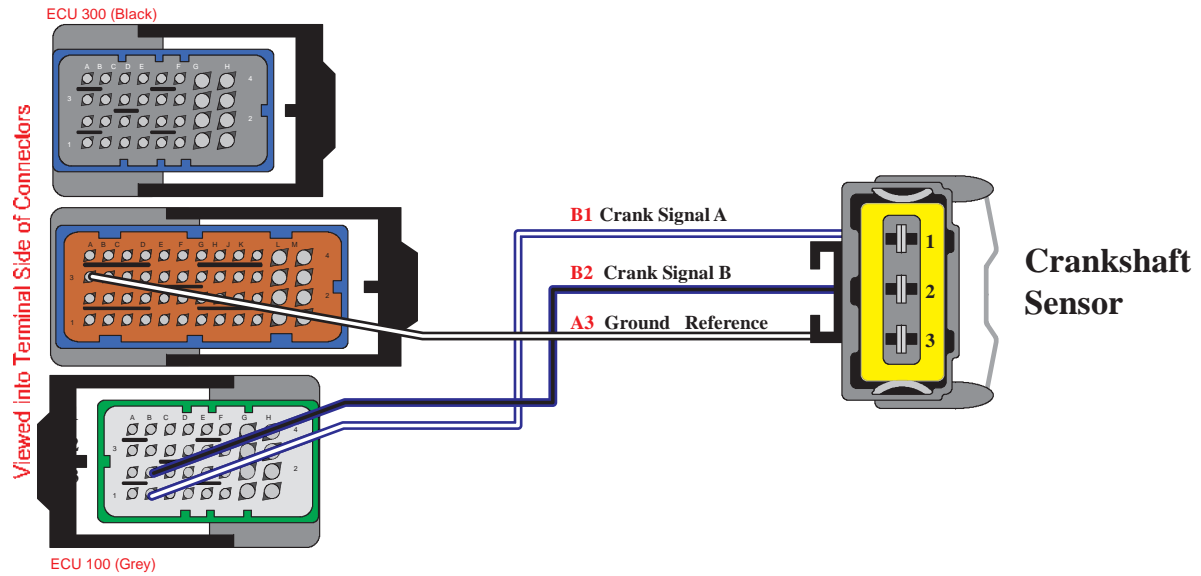

Circuit Trouble Codes

P - Code	Description	Summary
P0335	Loss of Synchronization	The number of pulses, or teeth on the timing rotor are not correct.
P0336	Engine Speed Sensor: Signal Error	The engine speed sensor signal is not valid.
P0337	Engine Speed Sensor: Low Limit	The engine speed signal voltage is outside the acceptable range.
P0338	Engine Speed Sensor: High Limit	The engine speed signal voltage is outside the acceptable range.

FUEL INJECTION / IGNITION / EXHAUST SYSTEMS

Camshaft Position Circuit

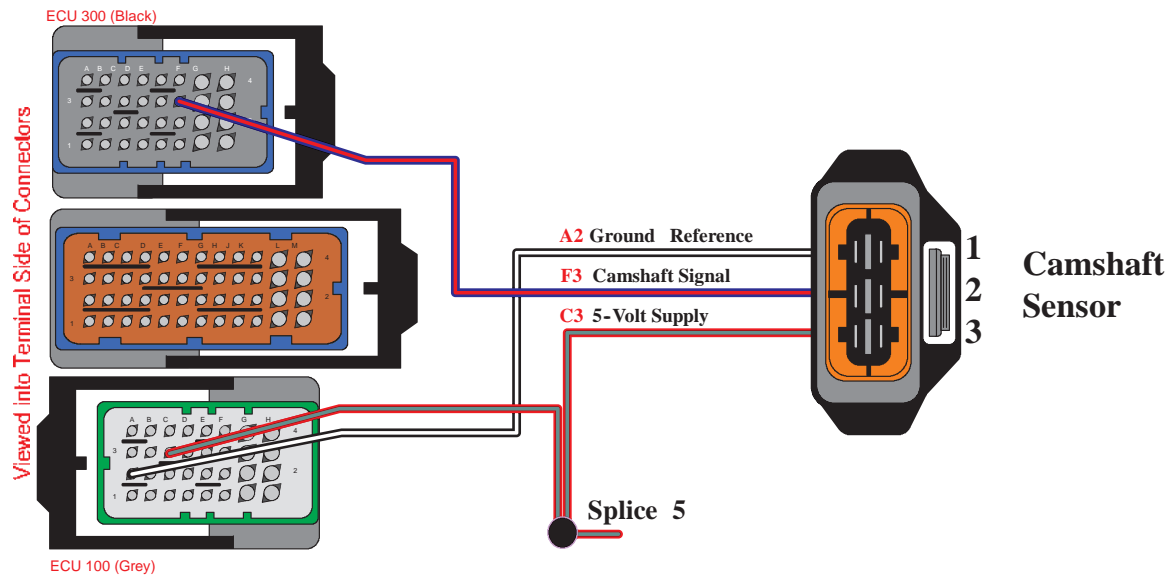

Circuit Trouble Codes

P - Code	Description	Summary
P0340	Camshaft Sensor Circuit: Plausibility Error	The camshaft sensor signal level is outside an acceptable range.
P0341	Camshaft Sensor Circuit: Signal Error	Indicates a problem with the camshaft sensor signal switch from high to low.
P0342	Camshaft Sensor Circuit: Short to Ground	The camshaft sensor signal is shorted to ground.
P0343	Camshaft Sensor Circuit: Open or Short to Battery	The camshaft sensor signal is shorted to open or battery voltage.

FUEL INJECTION / IGNITION / EXHAUST SYSTEMS

Knock Sensor Circuit

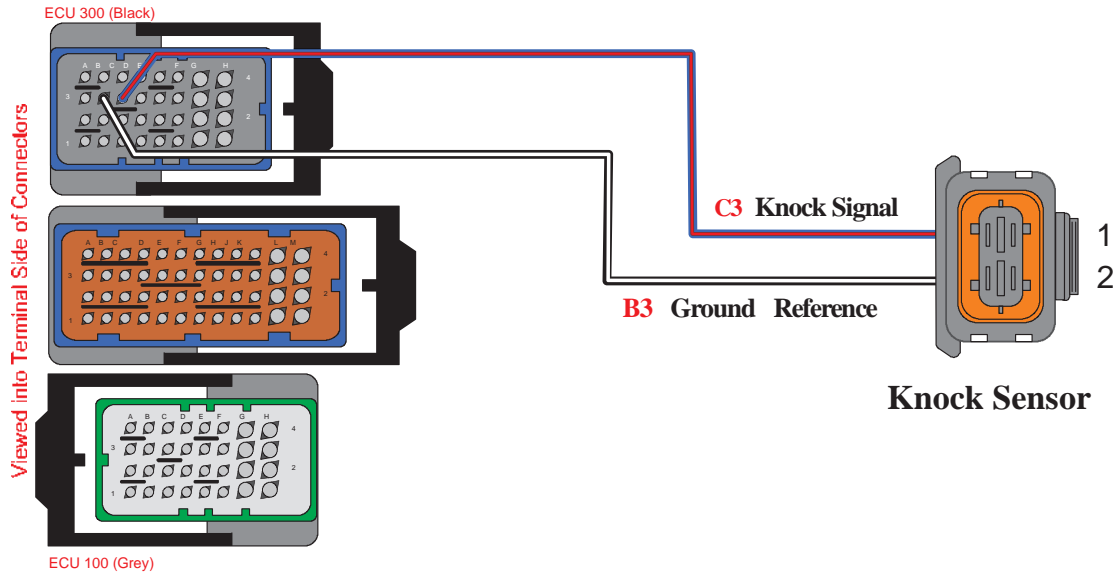

Circuit Trouble Codes

P - Code	Description	Summary
P0324	Knock Control Signal Failure	Indicates a failure with the knock control sensor.
P0327	Knock Sensor Signal Low	The knock sensor signal is too low.
P0328	Knock Sensor Signal High	The knock sensor signal is too high.

FUEL INJECTION / IGNITION / EXHAUST SYSTEMS

Wastegate Solenoid Circuit

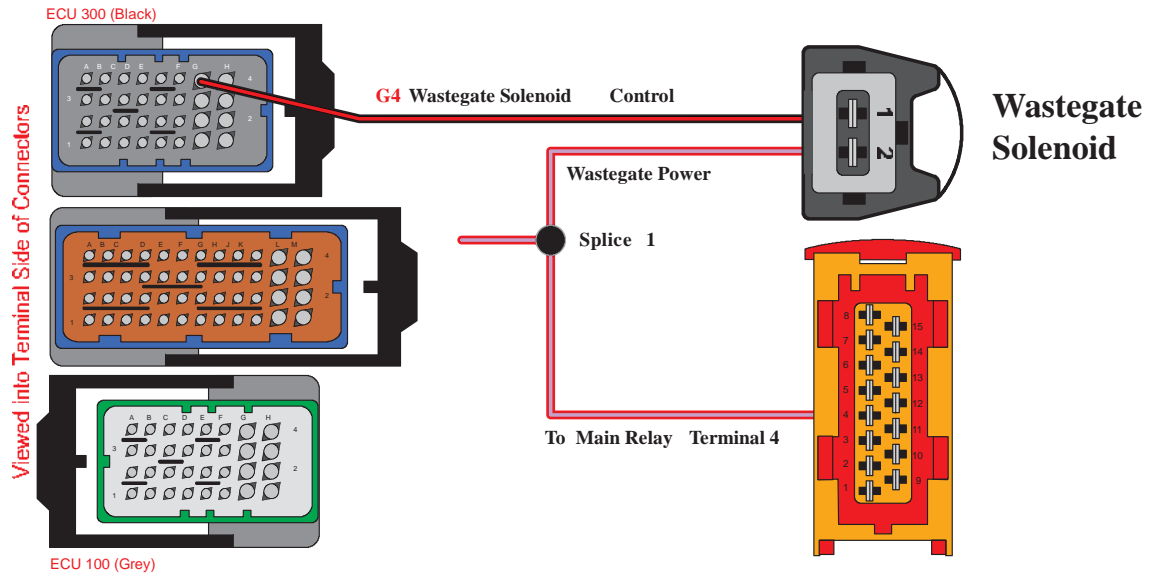

Circuit Trouble Codes

P - Code	Description	Summary
P0243	Wastegate Solenoid: Open Circuit	Indicates an open circuit within the control circuit.
P0245	Wastegate Solenoid: Short to Ground	Indicates the control circuit is shorted to ground.
P0246	Wastegate Solenoid: Short to Battery	Indicates the control circuit is shorted to battery voltage.

FUEL INJECTION / IGNITION / EXHAUST SYSTEMS

Fuel Pump / Main Relay Circuit

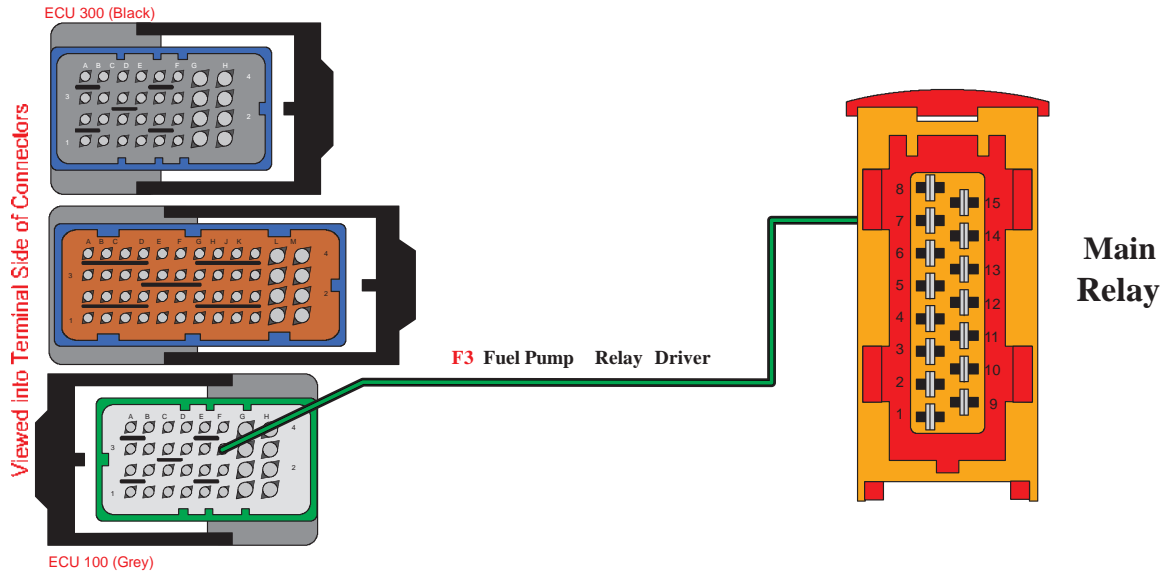

Circuit Trouble Codes

P - Code	Description	Summary
P0230	Fuel Pump: Open Load	Indicates the fuel pump relay circuit is open. Can be caused by a faulty relay, damaged wiring, damaged fuel pump, or ECU failure.
P0231	Fuel Pump: Short to Ground	Indicates the fuel pump relay is shorted to ground. Can be caused by a faulty relay, damaged wiring, damaged fuel pump, or ECU failure.
P0232	Fuel Pump: Short to Battery	Indicates the fuel pump relay circuit is shorted to battery voltage. Can be caused by a faulty relay, damaged wiring, damaged fuel pump, or ECU failure.

FUEL INJECTION / IGNITION / EXHAUST SYSTEMS

ECU / ECU Connections

The wiring harness connections at the ECU are a latching type. Extreme care must be taken when handling the connectors.

1. Remove connectors from front to back.
Re-install from back to front.

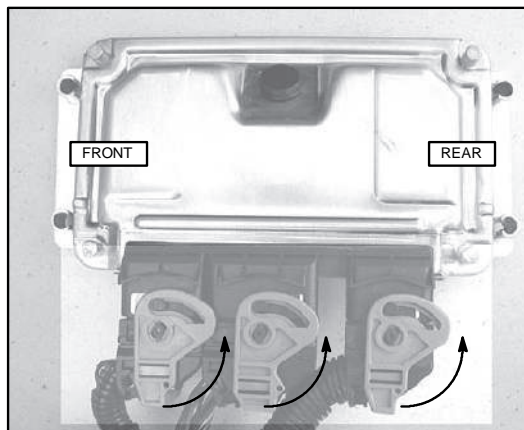

2. Unlock connector by pushing tab in, then rotate connector upwards. Re-install by pressing connector into ECU, then rotate connector down until audible "click" is heard.

Adaptation

The ECU runs in a closed-loop configuration between idle speed and 4000 RPM when not under acceleration. During the closed-loop configuration, the lambda sensor relays the amount of oxygen within the exhaust stream to the ECU. The ECU adjusts the fuel supply to achieve "lambda 1".

The ECU operates in the open-loop mode whenever the engine is accelerating or engine RPM exceeds 4000 RPM. In this mode, the ECU delivers the exact amount of fuel the engine requires to satisfy the torque demands of the operator for maximum performance.

Over time, normal wear and tear will occur to internal engine components. The ECU will constantly learn and adapt to the changing combustion characteristics and maintain optimum engine performance.



FUEL INJECTION / IGNITION / EXHAUST SYSTEMS

General Engine Management Trouble Codes

P - Code	Description	Summary
P0171	Fuel System: Maximum Adaption Limit Reached	Indicates the air/fuel mixture is too lean and the ECU has reached the maximum amount of fuel it can possibly deliver. Can be caused by a faulty O2 sensor, air leak, faulty injector or any other failure that would cause a lean-running condition.
P0172	Fuel System: Minimum Adaption Level Reached	Occurs when the engine is running at part-load and the O2 sensor indicates a constant RICH fuel condition for an extended period of time. Can be caused by a faulty O2 sensor, plugged air intake, leaky injector, or other mechanical failure.
P0234	Turbocharger Overboost Condition	Boost pressure has exceeded 33 psi (2.3 BAR) of more than 400 milliseconds.
P0560	Battery Voltage Plausibility Error	Battery voltage drops below 10.5 Vdc during operation.
P0562	Battery Voltage: Low	Battery voltage drops below 10.5 Vdc during operation.
P0563	Battery Voltage: High	Battery voltage exceeds regulated limit.
P0601	Main Microcontroller Reset	Replace ECU
P0604	Ram Memory Failure	
P0605	ROM Memory Failure	
P0606	ECU: EEPROM Memory or Checksum Error	

Electronic Throttle Body (ETB) / Pedal Position Unit (PPU)

A unique function of the Bosch ME- Motronic 7.4.4 Engine Management System is its use of a "Fly-By-Wire" or Electronic Throttle Control (ETC) system. In this system, the throttle flipper is not directly connected to the the throttle plate, but rather a pedal position unit or PPU.

Four components make up the ETC system:

- Pedal Position Unit (PPU)
- Engine Control Unit (ECU)
- Electronic Throttle Body (ETB)
- PPU Interface Box (IFB)

The PPU and ETB use two position sensors each to relay and verify the exact position of each component to the ECU. The ECU continuously monitors all four position sensors. In the event that any one sensor fails, the ECU will go into the LIMP-HOME mode, illuminate the CHECK ENGINE MIL light, and store the applicable trouble code.

ETB Learning Procedure

The ECU must perform the ECU / ETB learning procedure when ever the ECU or ETB is replaced with a new part. During the procedure, the ECU sweeps the throttle plate from full open to full close and "learns" the unique characteristics of the ETB.

1. Engine must be OFF, and lanyard removed from stop switch.
2. The PPU must be at absolute 0. (Increase the throttle flipper cable freeplay to ensure PPU is set to absolute zero and that cable is not kinked.)
3. Verify the battery voltage is at or above 10.1 Vdc, and that the engine temp. is between 42 and 176°F. The outside ambient temp. must be at least 42°F.
4. Install the new ETB or ECU.
5. Insert the lanyard into the stop switch for AT LEAST 30 seconds.
6. Remove lanyard and wait for AT LEAST 2 minutes.
7. Insert lanyard and re-start engine. Re-set the throttle flipper cable freeplay to what it was prior to performing process.

FUEL INJECTION / IGNITION / EXHAUST SYSTEMS

Electronic Throttle Body (ETB) / Pedal Position Unit (PPU) - Troubleshooting

The ETB and PPU components are integral to the engine management system. To perform any troubleshooting procedures, the ECU must be connected to the Digital Wrench™ diagnostic software.

VERIFY BATTERY IS FULLY CHARGED	
INSERT LANYARD INTO STOP SWITCH. DOES THE ELECTRICAL SYSTEM POWER UP? YES ↓ NO →	TROUBLESHOOT START/STOP SWITCH, MAIN RELAY, ECU, AND ASSOCIATED WIRING HARNESSSES AND CONNECTIONS. VERIFY SIFB IS NOT IN "SLEEP" MODE."
MOVE THROTTLE FLIPPER FROM CLOSED TO OPEN. DOES ETB THROTTLE PLATE MOVE WITH FLIPPER? YES ↓ NO →	PERFORM ETB LEARNING PROCEDURE PROCESS. CHECK ALL PPU AND ETB WIRING HARNESSSES AND CONNECTIONS. CONNECT DIGITAL WRENCH™ SOFTWARE TO ECU. VERIFY ETB LEARNING PROCEDURE DISPLAYS "TRUE". VERIFY ETB THROTTLE PLATE IS NOT OBSTRUCTED BY FOREIGN MATERIAL.
CONNECT DIGITAL WRENCH™ SOFTWARE TO ECU. ARE THE FOLLOWING SPECIFICATIONS TRUE? PPU POSITION SENSOR 1 & 2 OPERATING VOLTAGES ETB THROTTLE POSITION SENSOR 1 & 2 OPERATING VOLTAGES YES ↓ NO →	REPAIR ANY BROKEN CONNECTION VERIFY COMPONENTS ARE RECEIVING 5 Vdc REFERENCE SIGNAL FROM ECU REPLACE COMPONENT THAT IS OUT OF SPECIFICATION.
MONITOR OPERATING VOLTAGES AS THROTTLE FLIPPER IS MOVED FROM CLOSED TO OPEN POSITIONS. DO THE VOLTAGES MOVE SMOOTHLY WITHOUT DIPPING OR JUMPING AHEAD? YES ↓ NO →	VERIFY COMPONENTS ARE RECEIVING 5 Vdc REFERENCE SIGNAL FROM ECU. REPLACE COMPONENT THAT IS OUT OF SPECIFICATION.
LOCATE PPU AND ETB WIRING HARNESSSES. VISUALLY INSPECT ALL WIRES AND CONNECTIONS. "WIGGLE" HARNESS CONNECTIONS. PROBLEM(S) FOUND? YES ↓ NO →	REPAIR OR REPLACE AFFECTED WIRING HARNESS OR CONNECTOR.
VISUALLY INSPECT THE ETB AND PPU COMPONENTS FOR PHYSICAL DAMAGE. INSPECT ETB MOUNTING SURFACE FOR GASKET INTEGRITY. DAMAGE FOUND? YES ↓ NO →	REPLACE ETB GASKET IF DAMAGED. REPLACE ANY COMPONENT THAT IS MECHANICALLY DAMAGED.
POOR PERFORMANCE OR RUNABILITY ISSUE CANNOT BE ATTRIBUTED TO PPU OR ETB COMPONENTS OR FUNCTIONS. TROUBLESHOOTING ENDED.	

FUEL INJECTION / IGNITION / EXHAUST SYSTEMS

Exhaust System

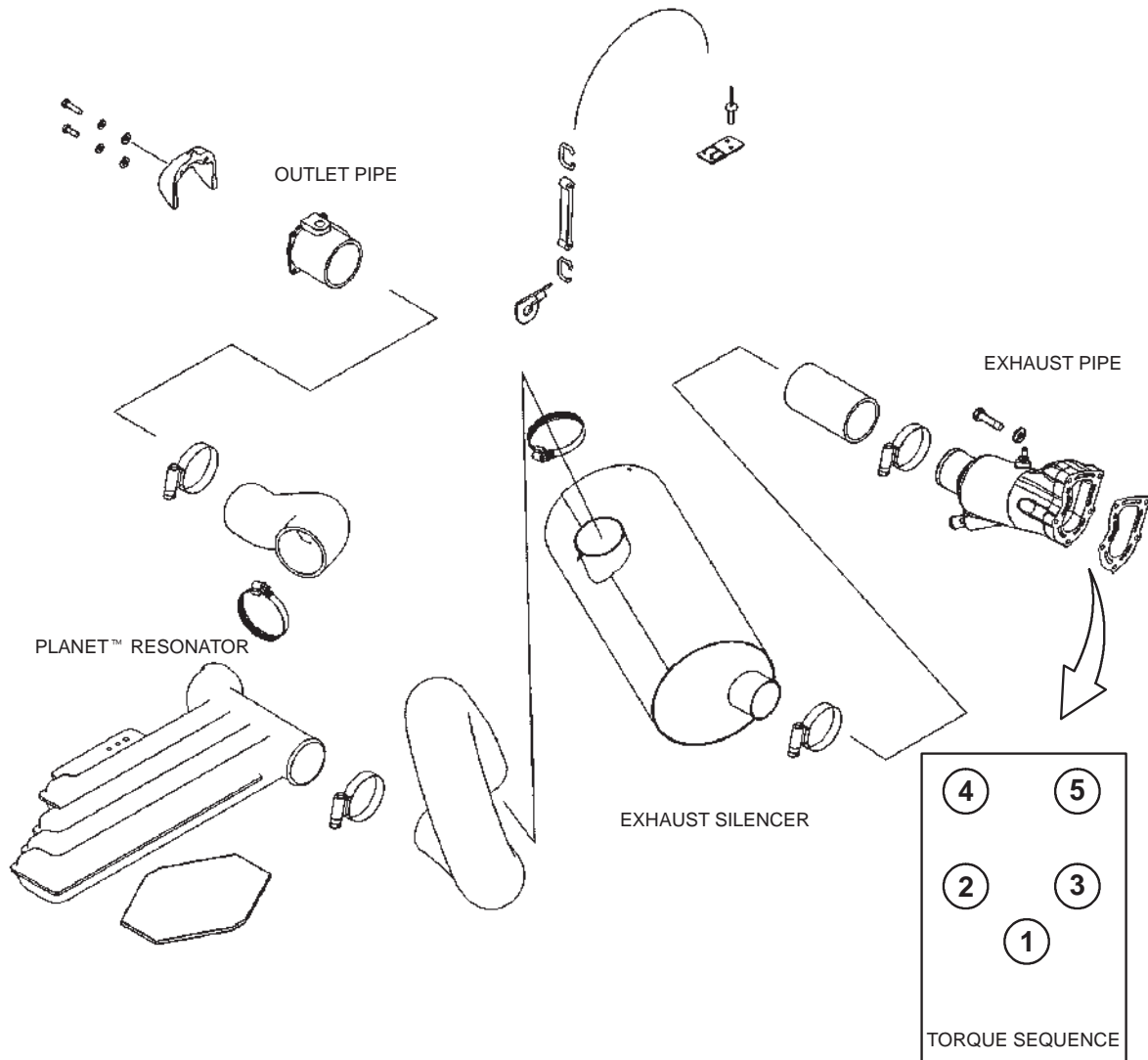

ASSEMBLY NOTES

Outlet Pipe Fastener Torque 6 ft.lbs. (8 Nm) Apply marine grade silicone to threads, and outlet pipe mating surfaces.

Exhaust Pipe Fastener Torque 22 ft.lbs. (30 Nm) Apply anti-seize lubricant to threads.

Large Gear Clamp Torque: 35 in.lbs. (4 Nm)

Tighten exhaust pipe fasteners in sequence shown in illustration.

FUEL INJECTION / IGNITION / EXHAUST SYSTEMS

Turbocharger

WARNING!

The turbocharger generates excessive heat and houses rotating parts which can cause severe injury and burns. Never touch any part of the turbocharger assembly while the engine is running. Allow the engine to completely cool before working with any component. Do not allow objects such as clothing, hair or fingers to come into contact with, or enter the compressor impeller while the engine is running.

The turbocharger uses the energy of expanding exhaust gases to power a compressor. Intake air is drawn into the compressor impeller and pre-compressed before entering the combustion chamber.

Components of the turbocharger employed on the MSX 110 and 150 watercraft are:

- Turbine
- Compressor (Impeller)
- Bearing House
- Wastegate Solenoid
- Wastegate Actuator

The turbine is directly exposed to exiting exhaust gases. The exhaust gases from each cylinder increase in speed as engine RPM increases and expand inside of the turbine housing. These gases are forced around the turbine housing and out into the exhaust pipe, thus rotating the turbine.

A compressor impeller is connected to the turbine via a shaft. The shaft's bearings are lubricated with engine oil and the bearing house is cooled by engine coolant. The compressor impeller draws fresh air into the compressor housing. The fresh air is compressed, then routed on to the intake system. At WOT, the turbine / impeller shaft can reach speeds in excess of 130,000 RPM.

The turbocharger bearing house is lubricated by the engine oil circuit and cooled by the engine coolant circuit. The exhaust manifold and turbine housing are cooled by the freshwater cooling circuit. A loss or failure in any one of the circuits will cause severe turbocharger and engine damage.

Wastegate

The amount of pre-compressed intake air generated by the compressor impeller is called boost pressure. Intake boost pressure rises and falls in direct relation to turbine / impeller speed. Excessive boost pressure is a destructive force and therefore is constantly monitored and adjusted by the ECU.

The wastegate solenoid and wastegate actuator are two critical components responsible for allowing the ECU to control boost pressure.

During operation, a small amount of pre-compressed air is routed to the wastegate solenoid. The wastegate solenoid is electronically controlled by the ECU. Once opened by the ECU, the wastegate solenoid routes pre-compressed air to the wastegate actuator.

The wastegate actuator houses a bellows, spring, and actuator arm. The actuator arm is connected to a small door located inside of the turbine housing. The actuator arm is held in the closed position by the spring. The bellows is exposed to boost pressure whenever the wastegate solenoid is opened. The actuator arm is pushed open when the boost pressure acting upon the bellows overcomes the spring pre-load. This action opens the small door inside the turbine housing allowing the exhaust gases to bypass the turbine blades.

Allowing the exhaust gasses to bypass the turbine blades decreases the turbine / impeller shaft RPM, and lowers boost pressure.

FUEL INJECTION / IGNITION / EXHAUST SYSTEMS

Turbocharger

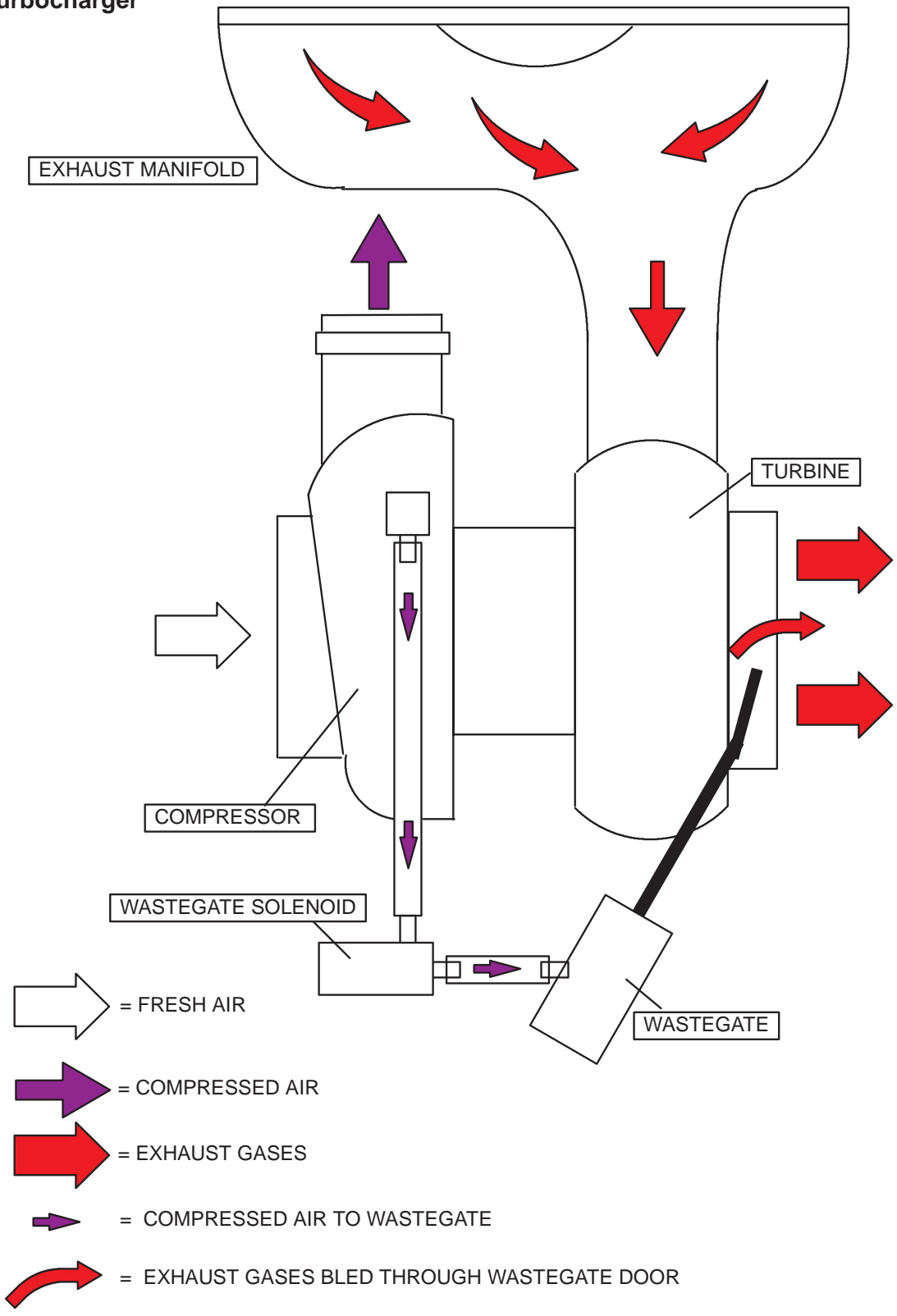

FUEL INJECTION / IGNITION / EXHAUST SYSTEMS

Charge Air Cooler (Intercooler)

Whenever air is compressed, the air molecules within the air are packed tightly together and create friction between each other. The increased friction between the air molecules generates heat. A charge air cooler removes most of the heat by transferring it to the freshwater cooling circuit.

The cooler the air, the more lbs./min of air the compressor will pump into the engine.

Turbocharger / Charge Air Cooler - Troubleshooting

A basic understanding of the turbocharger and charge air cooler must be obtained prior to troubleshooting each component.

It is important to realize the engine WILL NOT achieve maximum RPM, and thus maximum performance if either component is not working correctly.

Important Facts:

- The 110 and 150 engine platforms utilize the same turbocharger assembly.
- The 110 engine's charge air cooler is smaller and thus, less efficient than the 150's larger charge air cooler. The incoming air in a 150 engine will be denser and contain more oxygen than that in a 110 engine.
- The 110 engine does not utilize the air intake purge valve. The purge valve prevents boost spiking. Boost spiking occurs when boost pressure rises abruptly when the throttle plate is closed by the operator.
- The turbocharger is responsible for using spent exhaust gas energy to pre-compress incoming fresh air.
- The charge air cooler is responsible for lowering the pre-compressed fresh air's ambient temperature.
- During operation, carbon build up will occur on the turbocharger's turbine blades. This is normal. Never attempt to clean the turbine blades. Doing so will affect the balance and heat absorption characteristics of each blade and may cause turbocharger failure.

Turbocharger / Charge Air Cooler Troubleshooting

USE THE DIGITAL WRENCH™ SOFTWARE TO VERIFY WOT BOOST PRESSURE. DOES THE TURBOCHARGER GENERATE THE SPECIFIED AMOUNT? <p style="text-align: center; font-weight: bold;">NO →</p>	VISUALLY INSPECT ALL AIR INTAKE HOSES FOR LEAKS. INSPECT PURGE VALVE (150 ENGINE) FOR CRACKING OR LEAKING. PROBLEM SOLVED? NO →	INSPECT TURBINE AND COMPRESSOR BLADES FOR MECHANICAL / PHYSICAL DAMAGE. REPLACE TURBOCHARGER ASSEMBLY IF ANY DAMAGE IS FOUND. INSPECT THE CHARGE AIR COOLER FOR PROPER OPERATION. FRESHWATER INLET PRESSURE SHOULD BE AT LEAST 4 PSI. REPLACE CHARGE AIR COOLER IF OUTLET AIR TEMP. @ WOT IS > THAN THE FRESHWATER TEMP. + 59° F (15° C.) INSPECT THE WASTEGATE SOLENOID AND WASTEGATE FOR PROPER OPERATION. VERIFY THE BOOST REFERENCE HOSE LOCATED BETWEEN THE COMPRESSOR HOUSING AND WASTEGATE SOLENOID AND BETWEEN THE SOLENOID AND WASTEGATE IS NOT BLOCKED WITH OIL OR FOREIGN MATERIAL.
DOES THE TURBOCHARGER MAKE A "WHINING" OR "HOWLING" SOUND AS IT SPINS UP OR SPINS DOWN? <p style="text-align: center; font-weight: bold;">YES →</p>	REPLACE THE TURBOCHARGER ASSEMBLY. CHANGE THE ENGINE OIL AND FILTER VERIFY THE QUALITY OF THE ENGINE COOLANT.	

FUEL INJECTION / IGNITION / EXHAUST SYSTEMS

RPM Limiting Modes

The engine management software will limit engine RPM in several different scenarios. Engine RPM is limited to protect either the operator or engine from injury of damage.

RPM will be limited when the following occurs:

Limit Mode	Approximate RPM	Trigger
Idle RPM	1550 ± 50	Normal Operation
Maximum Engine RPM	7800 - 8400	Rev Limiter Function
Limp-Home Mode	1750	Failure with either the ECU, ETB, or PPU components.
Reverse Mode Anti-Submerge Protection	3400	Operator moves reverse handle from forward to position to either neutral or reverse positions.
Overboost Protection Mode*	4700 - 4800	110: Boost exceeded .8 - .9 BAR for more than 400ms. 150: Boost exceeded 1.3 BAR for more than 400ms.
Engine Temperature Overheat Protection*	1600 - 1800	The engine coolant temperature exceeds safe operating range.
Exhaust Manifold Temperature Overheat Protection	1800	The exhaust manifold freshwater cooling temperature exceeds safe operating range.

* = Indicates a TORQUE REDUCTION running mode. The ECU limits engine RPM by limiting the amount of torque generated by the engine. Stated RPM limit is an approximation and changes with current engine operating conditions.

The throttle plate opening (aperture), ignition timing, and fuel supply are controlled by the ECU to limit engine RPM in all modes except in the LIMP-HOME MODE.

Ignition timing is gradually retarded as the engine RPM reaches the established RPM limiter specification. If RPM exceeds 7600 RPM, ignition timing is retarded and fuel supply to one or both cylinders is reduced.

The limp-home mode occurs whenever a problem is detected as a safety issue in the Electronic Throttle Circuit. The ECU will cut power to the ETB in the event of a PPU, TPS, or wiring failure. When in the limp-home mode, the throttle plate returns to its default, non-power position. This position represents 6% open or approximately 1750 RPM.

Cold-Start Protection

The ECU will limit engine RPM to idle speed during a cold startup. Full power will return when the engine coolant temperature exceeds 140°F (60°C). The cold-start protection will last approximately 30 seconds after initial startup depending on current conditions.

FUEL INJECTION / IGNITION / EXHAUST SYSTEMS

Troubleshooting - Engine Will Not Turnover

System / Component	Inspection Procedure	Suspected Problem
Battery	Condition of Battery	Static battery voltage must be at least 12 Vdc. Voltage drop cannot drop below 10.5 Vdc while pushing START button. Clean battery of any foreign material or corrosion in or around battery terminals. Verify battery connections are clean and tight.
Fuses	Verify 15AMP ignition fuse located in chassis harness pod is not blown.	Loose or blown fuse.
Mechanical failure within drive system, impeller jammed or locked.	Inspect the propulsion driveline. Verify impeller, driveshaft, and drive couplers rotate freely without binding.	Mechanical driveline failure or propulsion system jammed by foreign material.
Start Button Circuit	Inspect: Tether attachment Battery and harness connection and LH control assembly. Solenoid Connections Solenoid Operation Engine electrical grounding Start switch function Electrical harness between LH control assembly and engine wiring harness / ECU.	No power to start switch No power to solenoid No power from solenoid to starter
Starter Motor Function	Inspect Starter motor for electrical or mechanical functions. Starter drive gears for proper operation.	Starter motor requires excessive voltage to rotate Starter motor is mechanically jammed either by foreign material or gears. Sprague clutch is broken or jammed.

FUEL INJECTION / IGNITION / EXHAUST SYSTEMS

Troubleshooting - Engine Turns-Over; Will Not Start

System / Component	Inspection Procedure	Suspected Problem
Battery	Condition of Battery	Static battery voltage must be at least 12 Vdc. Voltage drop cannot drop below 10.5 Vdc while pushing START button. Clean battery of any foreign material or corrosion in or around battery terminals. Verify battery connections are clean and tight.
Ignition System	Insert lanyard into STOP switch. An audible series of relay switching and clicking should be heard. Move the throttle flipper from closed to open several times. The throttle plate must move in conjunction with each throttle flipper movement. Verify that no 15AMP fuses are blown in the engine fuse block.	Inserting the lanyard into the STOP switch provides battery voltage to the START button and to the ECU. If the starter motor turns when the START button is pushed, then the START/STOP switch is OK should be providing battery voltage to the ECU via the PURPLE circuit.
Main Relay	Provide battery voltage to PIN 3 and ground PIN 10. Continuity should be seen between PINS 11 and 2. Provide battery voltage to PIN 3 and ground PINS 10 and 7. Continuity should be seen between PINS 15 / 8 and 13, 6, 5, 4, and 7.	Defective relay. During normal operation, the ECU grounds PINS 7 and 10 to close the main ECU power relay and fuel pump driver relay. The fuel pump driver relay also supplies battery voltage to the lambda sensor, ignition coils, fuel injectors and wastegate solenoid.
ECU (Engine Management System)	Use the Digital Wrench™ diagnostic software to review current data values and download any trouble codes. Repair any problems that are triggering trouble codes.	Failed ECU or EMS components preventing engine from starting.
Fuel System	Verify fresh fuel is in the fuel tank. Verify fuel rail pressure is meeting specification. Test each fuel injector for correct resistance. Check 10AMP fuel pump fuse located in the chassis harness fuse block. Check condition of fuel filter. If foreign material is found in tank, clean tank and replace fuel filter.	Low or no fuel in tank. Damaged fuel injectors. Damaged fuel delivery system of fuel pump.
Propulsion System	Verify there are no damaged parts in the inlet pump or impeller housing.	Mechanical failure causing high friction load on starting system.
Starting System	Verify condition of starter motor. Check voltage drop when START button is pressed.	Voltage drop cannot exceed 10.5 vDC while pushing START button.
Mechanical Condition of Engine	Check spark plug for correct plug and proper gap. Check cylinder compression and compare against specification.	Incorrect spark plug usage can cause serious engine damage. Cylinders with low compression will cause hard starting issues and poor performance.

FUEL INJECTION / IGNITION / EXHAUST SYSTEMS

Troubleshooting - Engine Stalls; Will Re-Start

System / Component	Inspection Procedure	Suspected Problem
Battery	Condition of Battery	Static battery voltage must be at least 12 Vdc. Voltage drop cannot drop below 10.5 Vdc while pushing START button. Clean battery of any foreign material or corrosion in or around battery terminals. Verify battery connections are clean and tight.
Alternator / Charging System	Connect multimeter to positive and negative battery terminals. Start engine. Voltage at battery terminals should be at least 14 vDC.	Faulty alternator or voltage regulator. Poor battery condition. (Battery cannot take or hold charge.)
Air Intake System	Inspect for blockage in intake hoses. Look for signs of water intrusion.	
Fuel System	Inspect: Fuel Filter Fuel Level Fuel Pump Fuel Pressure Fuel Hoses Fuel Tank Vent Hose Fuel Pump Wiring Connections and Connectors.	
ECU (Engine Management System)	Use the Digital Wrench™ diagnostic software to check for trouble codes and operating data.	
Oil Lubrication System	Verify the oil level is not over the MAXIMUM mark on the dipstick. Remove any excess oil from the oil tank. Clean or replace the boost / air temp. and manifold pressure sensors if oil level exceeded the MAXIMUM mark.	

FUEL INJECTION / IGNITION / EXHAUST SYSTEMS

Troubleshooting - Engine Stalls; Will Not Re-Start

System / Component	Inspection Procedure	Suspected Problem
Battery	Condition of Battery	Static battery voltage must be at least 12 Vdc. Voltage drop cannot drop below 10.5 Vdc while pushing START button. Clean battery of any foreign material or corrosion in or around battery terminals. Verify battery connections are clean and tight.
Cooling System	Inspect coolant level. Inspect cooling hoses for kinks, leaks, or loose clamps. Inspect water-to-water heat exchanger. Look for oil in the engine coolant, or engine coolant in the engine oil.	Engine overheat - seizure.
Oil Lubrication System	Inspect oil level. Inspect oil hoses for kinks, leaks, or loose clamps. Inspect oil cooler. Look for engine coolant in oil or freshwater in the engine oil.	Lack of lubrication engine seizure.
Main Relay	Check function of relay when lanyard is installed in STOP switch.	
Air Intake System	Check intake hoses for blockage. Check for signs of water intrusion.	
Fuel Management and Ignition System (ECU)	Check all components and connectors. use the digital Wrench™ diagnostic software to download any trouble codes and view current engine data.	
Exhaust System	Check all exhaust hoses for blockage. Check Planet™ resonator for blockage.	
Engine Condition	Check cylinder compression. Verify correct spark plug is being used.	
Fuel System	Check condition of fuel in fuel tank. Fill with fresh fuel. Check operation of fuel pump, and fuel injectors. Check fuel rail pressure. Check all fuel hoses and vent lines for kinks, leaks, or incorrect routings.	

FUEL INJECTION / IGNITION / EXHAUST SYSTEMS

Troubleshooting - Engine Lacks Performance, RPM Limits

Indicated Problem	Suspected Problem	Solution
Engine RPM will not rise with throttle flipper movement.	No reaction to throttle input. PPU not working or connected. ETB not learned.	<p>Check ETB and PPU wiring harness connections.</p> <p>Perform ECU reset procedure by inserting lanyard, then disconnecting main relay. Reconnect main relay and wait at least one minute. ECU will re-learn ETB.</p> <p>Use diagnostic software to inspect throttle position function and accuracy.</p> <p>Replace PPU or ETB.</p>
Engine idle RPM above 1600 RPM.	Air leak at manifold or after ETB assembly.	<p>Verify all hose connections at throttle body and air intake manifold.</p> <p>Verify ETB is mounted securely to manifold.</p> <p>Verify drain plug, sensors, and banjo fittings are installed securely on intake manifold.</p>
Engine RPM limited to 1800 ± 50 AND CHECK ENGINE MIL light is ON.	ECU is in LIMP HOME MODE.	<p>Use diagnostic software to find any trouble codes associated with ETB, or PPU components.</p> <p>Check ETB and PPU wiring harness connections.</p> <p>Replace PPU or ETB.</p>
Engine RPM limited to 2000 ± 50 and WATER TEMPERATURE WARNING indicator is ON.	Exhaust manifold thermoswitch is detecting a water temperature of 60°C or higher.	<p>DO NOT RUN WATERCRAFT FOR MORE THAN 30 SECONDS!</p> <p>Check all freshwater hose connections. Verify there are no kinks or cuts on any of the hoses.</p> <p>Check pump assembly for weeds or foreign material.</p> <p>Flush the freshwater cooling circuit using flush kit.</p>
Engine RPM limited to 2000 ± 200 and WATER TEMPERATURE WARNING indicator is ON after watercraft has re-started after sitting off of five to ten minutes. <i>(Will only occur on models with ECUs using Level 5 software.)</i>	Exhaust manifold thermoswitch is detecting a water temperature of 60°C or higher.	<p>Condition caused by heat soak within exhaust manifold.</p> <p>Full power will return once freshwater circuit fills and cools exhaust manifold.</p>
Engine RPM limited to 3000 ± 50 and the WATER TEMPERATURE WARNING indicator is ON.	Engine cooling circuit is too hot. Internal engine temperature at or above 87°C.	<p>DO NOT RUN WATERCRAFT FOR MORE THAN 30 SECONDS!</p> <p>Check the engine coolant level and test condition of coolant boil over protection using coolant hydrometer.</p> <p>check the engine cooling system circuit for leaks, plugs, etc.</p> <p>Perform a cooling system pressure-leak test.</p> <p>Perform a cylinder compression test.</p> <p>Verify there is no oil in the coolant, or coolant in the oil.</p>
Engine RPM is limited to 3400 ± 50 RPM with NO WARNING INDICATORS ON.	Reverse or ESP mode RPM limit. Engine runs fine between idle speed and 3400 RPM.	<p>Verify reverse gate is in the UP position.</p> <p>Check reverse switch wiring harness connections.</p> <p>Test reverse switch for proper operation.</p> <p>Test the ESP system.</p> <p>Check ESP wiring harness connections.</p>

FUEL INJECTION / IGNITION / EXHAUST SYSTEMS

Troubleshooting - Engine Lacks Performance / RPM Limits - Continued

Indicated Problem	Suspected Problem	Solution
Engine RPM limited to 4700 ± 200 and the CHECK ENGINE MIL LIGHT is on.	ECU has detected an overboost condition.	<p>Stop engine, pull lanyard and then re-insert lanyard.</p> <p>If problem persists, check air intake system hoses for leaks.</p> <p>Use diagnostic software and check for trouble codes.</p> <p>Check all boost control hoses.</p> <p>Check operation of wastegate solenoid.</p> <p>Check wastegate linkage and wastegate operation.</p> <p>Verify oil level is not over MAXIMUM.</p> <p>Clean boost control hose banjo bolt fitting.</p>
Engine RPM is limited to 4500 - 5500 after initially starting engine.	ECU will limit engine RPM in the event that the internal engine temperature is below 60C. This is a protection feature.	Full power will return once engine warms up.
Engine RPM is limited to 6000 to 6500.	Air leak within air intake system or boost control system.	<p>Check all hoses associated with air intake system and boost control system.</p> <p>Check for air leaks.</p> <p>Use diagnostic software to check for trouble codes and operating parameters.</p>
Engine RPM is limited to 6800 to 7000.	<p>ECU is detecting either a knock sensor failure or a auto-ignition condition exists. (Piston Knock)</p> <p>ECU will retard engine timing up to 9 degrees BTDC when knock sensor fails or detects auto-ignition. If condition persists, ECU will open wastegate solenoid and drop boost pressure.</p>	<p>Use PREMIUM GRADE fuel to obtain maximum engine performance. 91, 92, or 93 octane recommended.</p> <p>Check for foreign material or water within fuel system.</p> <p>Check boost control hose connected to fuel pressure regulator.</p> <p>Use diagnostic software to check for trouble codes.</p> <p>Verify correct impeller is installed.</p>
Boat fails to reach top speed.	<p>All of the above +</p> <p>Turbocharger not making enough boost pressure.</p> <p>Mechanical failure with engine, engine subsystem, or pump assembly.</p> <p>Environmental Conditions.</p>	<p>Use diagnostic software to download trouble codes.</p> <p>Check the spark plugs for proper gap, etc..</p> <p>Check ignition coils.</p> <p>Check the engine and chassis wiring harnesses for damage.</p> <p>Check and perform all maintenance-related issues.</p> <p>Perform the boost pressure check by connecting a pressure gauge to the air intake manifold drain fitting.</p> <p>If boost pressure is lower than specification, check the following:</p> <p>Check air intake system for leaks.</p> <p>Check or replace Boost sensor</p> <p>Check boost control hoses.</p> <p>Check or replace wastegate solenoid.</p> <p>Visually inspect the turbocharger turbine and compressor wheels and blades. Replace turbocharger if blades are damaged or worn.</p> <p>Use PREMIUM GRADE fuel to obtain maximum engine performance. 91, 92, 93 octane recommended.</p>

FUEL INJECTION / IGNITION / EXHAUST SYSTEMS

Troubleshooting - Engine Lacks Performance / RPM Limits - Continued

Indicated Problem	Inspection Procedure	Suspected Problem
Air Intake System	Inspect condition of hoses and clamps. Inspect condition of intake screen. Inspect the intake system purge valve.	
Alternator / Charging System	Verify at least 14 vDC present at battery terminals at idle speed.	
ECU	Use Digital Wrench™ diagnostic software to download any trouble codes and monitor engine performance data.	
Electrical Wiring Harness	Inspect engine and chassis electrical harnesses. Verify all connectors are clean and tight.	
PPU and ETB Operation	Follow troubleshooting procedures outlined within this chapter.	
Exhaust System	Inspect system of blockage. Inspect system for exhaust leaks.	
Fuel Delivery System	Inspect fuel level and fuel quality. Verify fuel pressure meets specification. Inspect all fuel and vent hose connections and routings. Inspect for leaks.	
ECU - Engine Management System	Inspect all sensors for proper operation and correct data values using Digital Wrench diagnostic software.	
Mechanical Condition of Engine	Verify correct spark plug is use with correct gap. Check cylinder compression.	
Propulsion System	Verify impeller is not worn. Check for driveline obstruction or worn/broken parts.	
Turbocharger / Charge Air Cooler	Follow troubleshooting procedures outlined within this chapter.	

FUEL INJECTION / IGNITION / EXHAUST SYSTEMS

Troubleshooting

Indicated Problem	Inspection Procedure	Suspected Problem
Idle Speed Too High	Adjust throttle flipper freeplay to zero. (0) Check for air leaks around ETB assembly. Re-Torque ETB fasteners. Verify correct ESP system operation. (ESP circuit grounded.)	
Inconsistent Performance	Inspect: Condition of wastegate control hoses. Condition of wastegate solenoid and wastegate. Perform electrical diagnostics on wastegate solenoid using Digital Wrench™ diagnostic software. Check for oil intrusion into wastegate control hoses.	Wastegate / Boost Control
No Diagnostic Communication	Verify system “wakes up” after inserting the lanyard into the STOP switch. Push START button to re-set SIFB box. Check condition of main relay. Check condition of START / STOP switch assembly. Inspect communication cables.	



POLARIS[®] **WATERCRAFT**

MSX 110 / 150 Service Manual

Propulsion

Pump Specifications / Quick Reference Guide	6.1
Fastener Guide	6.2
Ventilation / Cavitation Troubleshooting	6.3
Pump Assembly Illustration	6.4
Stator Assembly Illustration	6.5
Driveshaft Assembly Illustration	6.6
Pump Induction Assembly Illustration	6.7
Pump Removal and Assembly	6.8
Bearing Carrier Removal and Installation	6.9
Driveshaft Shim Procedure	6.10
Driveline Inspections	6.11
Stator Disassembly and Assembly	6.12 - 6.14
Driveshaft Alignment Procedure	6.15 - 6.19
Sacrificial Anode	6.20
Intake Scoop / Ride Plate Removal and Installation	6.21 - 6.22

PROPULSION

WARNING

Before working on the drive system, be sure the lanyard cord and lock plate are removed from the engine stop switch to kill the ignition or severe injury could result.

Pump Specifications

	MSX 110	MSX 150
Pump Extension	YES 4"	YES 4"
Pump Wedge	5432841 (4°)	5432841 (4°)
Stationary Nozzle	1350013	1350013
Impeller (# of blades)*	TBA	12 - 18 3 Blade
Drive Coupler**	Three-Piece Coupler	Three-Piece Coupler
Bearing Carrier	Sealed Bearings	Sealed Bearings
Driveshaft	1590349 22.247" ± 0.15"	1590349 22.247" ± 0.15"
Ride Plate	5631257-329 MSX	5631257-329 MSX
Inlet Grate	5631328-067 4-Bar	5631328-067 4-Bar
Driveshaft Bumper	5410663 (Between Impeller and Shaft)	5410663 (Between Impeller and Shaft)

*Impeller torque for ALL Polaris impellers: 100ft.lbs. (138Nm) Apply Loctite™ 242 to threads.

Final Drive / Propulsion Quick Reference Guide

Topic	Service Recommendations
Drive Couplers	Inspect at preseason and at year end.
Driveshaft Bearing Carrier	Inspect at preseason and at year end.
Impeller Wear	Inspect at preseason, every six months, and at year end. Inspect stator cone at preseason and at year end.
Steering / Reverse / Trim Pivot Bushings	Service Limit: .335in. Inspect at 100 hour intervals.
Sacrificial Anode	Service Limit: Replace when 50 % worn. Inspect at pre-ride.
Pump Housing Seals / O-rings	Replace all seals and o-rings whenever pump assembly is removed from watercraft. Apply grease and/or silicone to applicable parts as outlined in this chapter.
Inlet Screen	Inspect at pre-ride, preseason, and at end of year.
Siphon Bilge / Bilge System	Inspect screens / pump mounting at pre-ride, preseason and at end of year.
Drive Coupler Shroud	Inspect at pre-ride, preseason and at end of year.
Pump Assembly Fasteners	Inspect at preseason and at end of year.

PROPULSION

Fastener Guide - Final Drive / Propulsion

Component(s)	Torque		Remarks
	FT.LBS.	Nm	
Driveshaft / Bearing Carrier			
Bearing Carrier - To - Hull	14	19	Tighten in criss-cross pattern.
Coupler Guard	35 (In. Lbs.)	3.9	Apply Loctite™ 242
Pump Assembly			
Zinc Anode	25 (In. Lbs.)	2.8	Apply Loctite™ 242
Impeller Torque	100	138	Apply Loctite™ 242 Verify impeller rotates freely three times.
Tail Cone	40 (In. Lbs.)	4.5	
Steering Nozzle	14	19	Apply Loctite™ 242
Reverse Nozzle	14	19	Apply Loctite™ 242
Pump Assembly - To - Pump Housing Bolts	1st Step: 2ft.lbs. 2nd Step: 14ft.lbs.	1st Step: 2.7 2nd Step: 19	Apply Loctite™ 242. Tighten in criss-cross pattern.
Pump Housing Bolts	28	38	Tighten in correct order: Top Right / Bottom Left / Bottom Right / Top Left
Ride Plate / Inlet Grate			
Inlet Grate / Ride Plate	8	11	Apply light amount of marine silicone to threads.
Paddle Wheel	30 (In. Lbs.)	3	
Paddle Wheel Thru-Hull Nut	25 (in. Lbs.)	2.8	Apply light amount of marine silicone to threads.

PROPULSION

Ventilation Troubleshooting

Ventilation results when air enters the pump inlet tract and is compressed by the impeller, causing a reduction in thrust and an increase in engine RPM. Small leaks are often difficult to diagnose.

Some possible sources of air are:

1. An improperly sealed intake scoop is the most common cause of ventilation. Make sure the scoop has a complete bead of Marine Grade silicone sealer all the way around without any gaps or pin holes.
2. Ride plate - The ride plate must be completely sealed in the area around the intake scoop, and also in the area where the hull meets the pump cavity.
3. Driveshaft bearing housing or through hull fitting - If the drive shaft bearing carrier seals are worn or damaged, air may be drawn into the pump from the engine compartment. Also inspect the through-hull fitting. The entire circumference of the fitting must be sealed to prevent water from entering the hull, and air from entering the pump.
4. Incorrectly mounted pump. This can be caused by an improperly installed intake scoop or a misaligned pump (there should be no detectable gap between pump housing and hull).

Cavitation Troubleshooting

Cavitation results when a low pressure area is created in the vicinity of the impeller blades, causing the surrounding water to boil or more accurately, the gas bubbles within the water implode with a destructive force. Cavitation may be caused by cracked, damaged, bent or broken impeller blades, or an excessively worn impeller or housing (check impeller clearance).

Ventilation or cavitation can drastically reduce the amount of output thrust produced by the pump. Evidence of either problem may appear as burn marks on the impeller and stator vanes in the pump.

PROPULSION

Pump Assembly

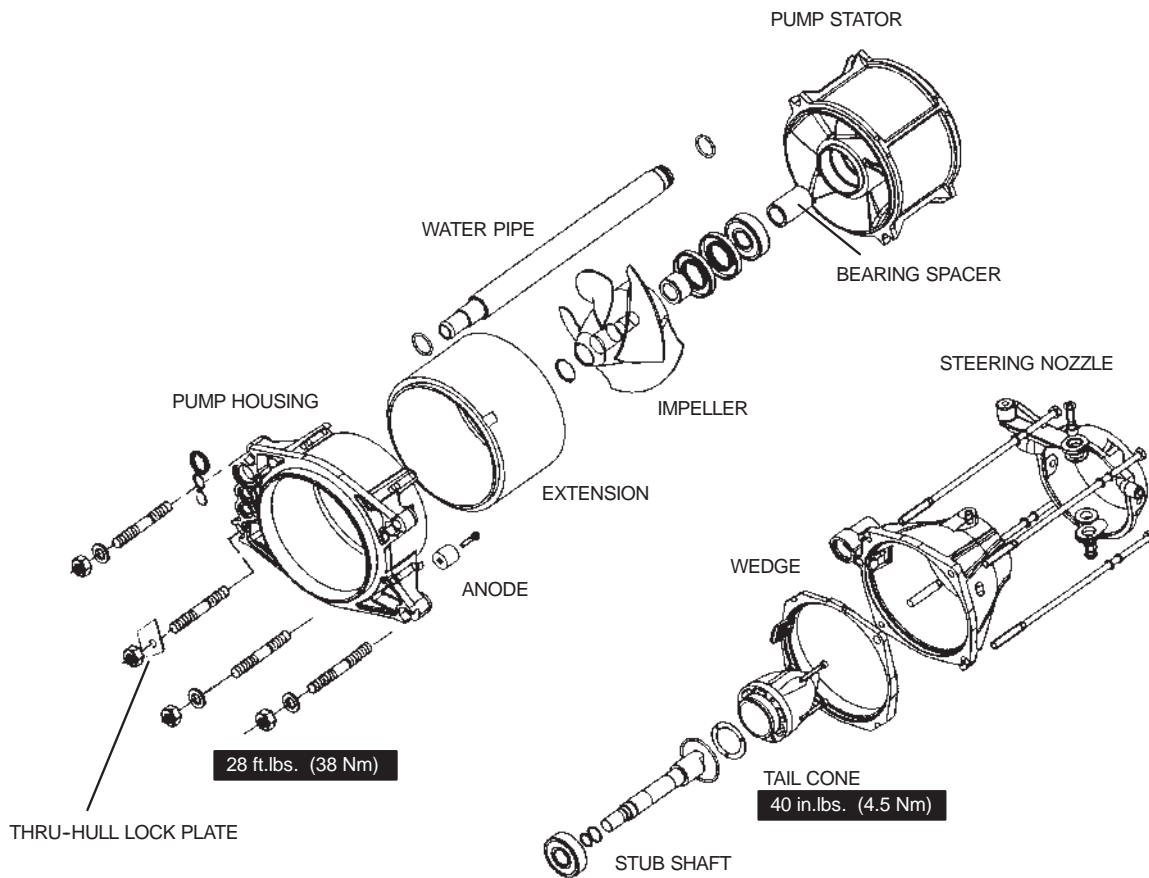

ASSEMBLY NOTES

Pump Housing - To- Hull Fasteners Torque: 28 ft.lbs. (38 Nm) Follow sequence listed on page 5.2.

Anode Fastener Torque: 25 in.lbs. (2.8 Nm)

Impeller Torque: 100 ft.lbs. (138 Nm) Apply Loctite™ 242 to threads.

Tail Cone Fastener Torque: 40 in.lbs. (4.5 Nm)

Pump Mounting Bolts Torque: 1st Step: 2 ft.lbs. / 2nd Step: 14 ft.lbs. (2.7 / 19 Nm)

Steering Nozzle Fastener Torque: 14 ft.lbs. (19 Nm) Apply Loctite™ 242.

Reverse Nozzle Fastener Torque: 14 ft.lbs. (19 Nm) Apply Loctite™ 242.

Thru-hull lock plate must be installed with flat against steering cable thru-hull nut.

Apply anti-seize to pump component mating surfaces.

Apply premium grease to o-rings prior to assembly.

Pump assembly must be flush against hull to prevent leakage or ventilation. Apply liberal amount of marine-grade silicone to mating surfaces.

Verify presence of o-ring between pump stator and tail cone.

CAUTION: DO NOT ALLOW SILICONE TO ENTER WATER HOSE OR PIPE ORIFICES. SERIOUS ENGINE DAMAGE MAY OCCUR!

PROPULSION

Stator Assembly

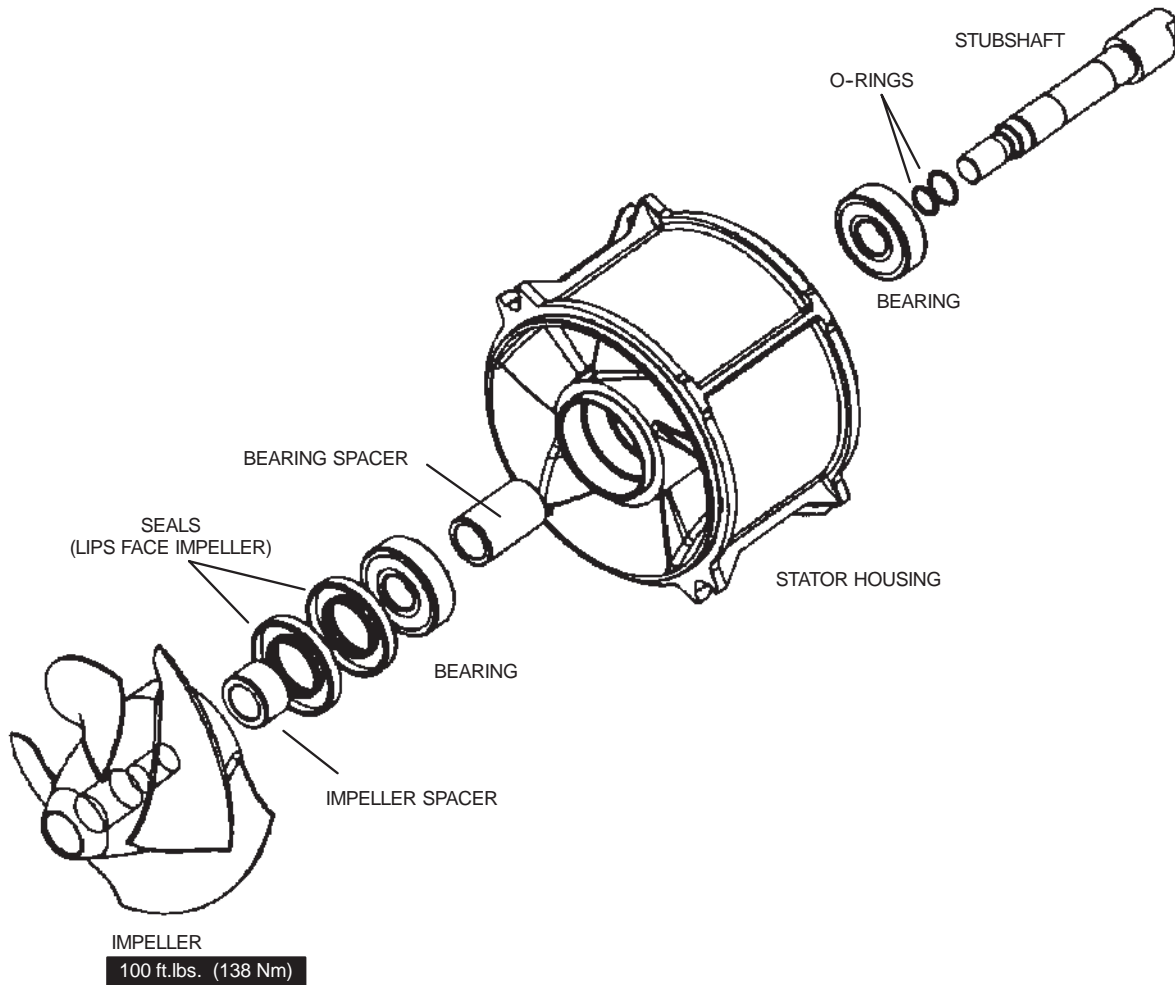

ASSEMBLY NOTES

Impeller Torque: 100 ft.lbs. (138 Nm) Apply Loctite 242 to threads.
Bearing Spacer Length: 1.730 in. 43.94mm (Service Limit)

Apply light film of Premium grease to seal lips, o-rings, and stubshaft during installation.
Bearing spacer length is critical to driveline operation. Replace if length is smaller than service limit.
Seal springs and / or seal lips must not be folded over, stretched, torn, etc. by impeller spacer during stubshaft installation.

PROPULSION

Driveshaft / Bearing Carrier Assembly

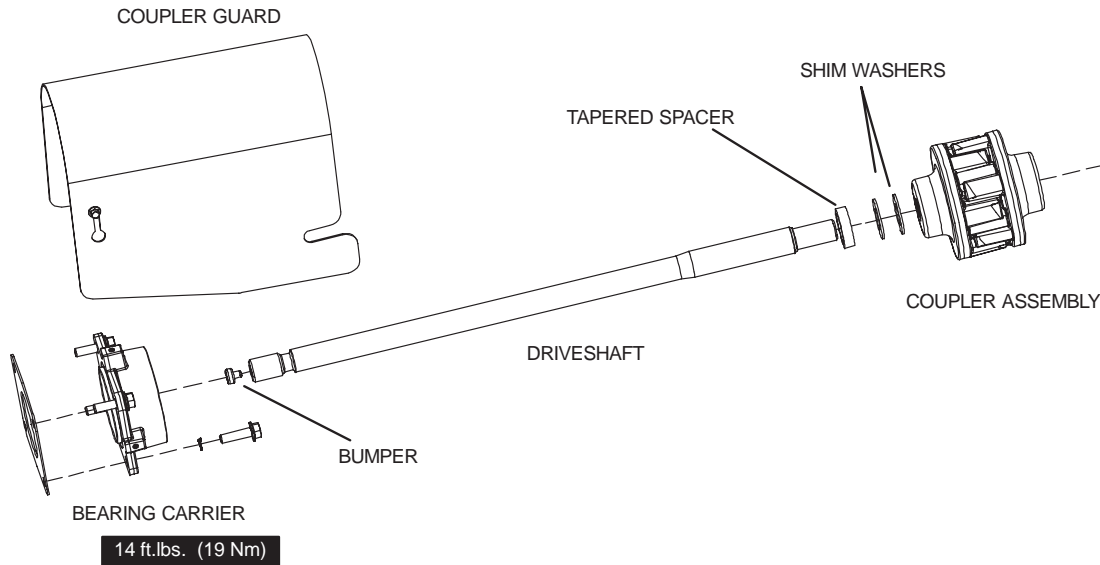

ASSEMBLY NOTES

Bearing Carrier Fastener Torque: 14 ft.lbs. (19 Nm) Tighten in criss-cross pattern.
Driveshaft Run Out Service Limit: .005" (.13mm)

Fit tapered end of spacer over driveshaft taper.
Bumper **MUST** be installed between impeller and driveshaft.
Use light film of premium grease on carrier seals and shaft to assist in driveshaft installation.
Apply small amount of Premium grease to tapered spacer inside diameter.

During assembly, perform the driveshaft shim procedure as outlined on page 6.10.

PROPULSION

Pump Induction Assembly

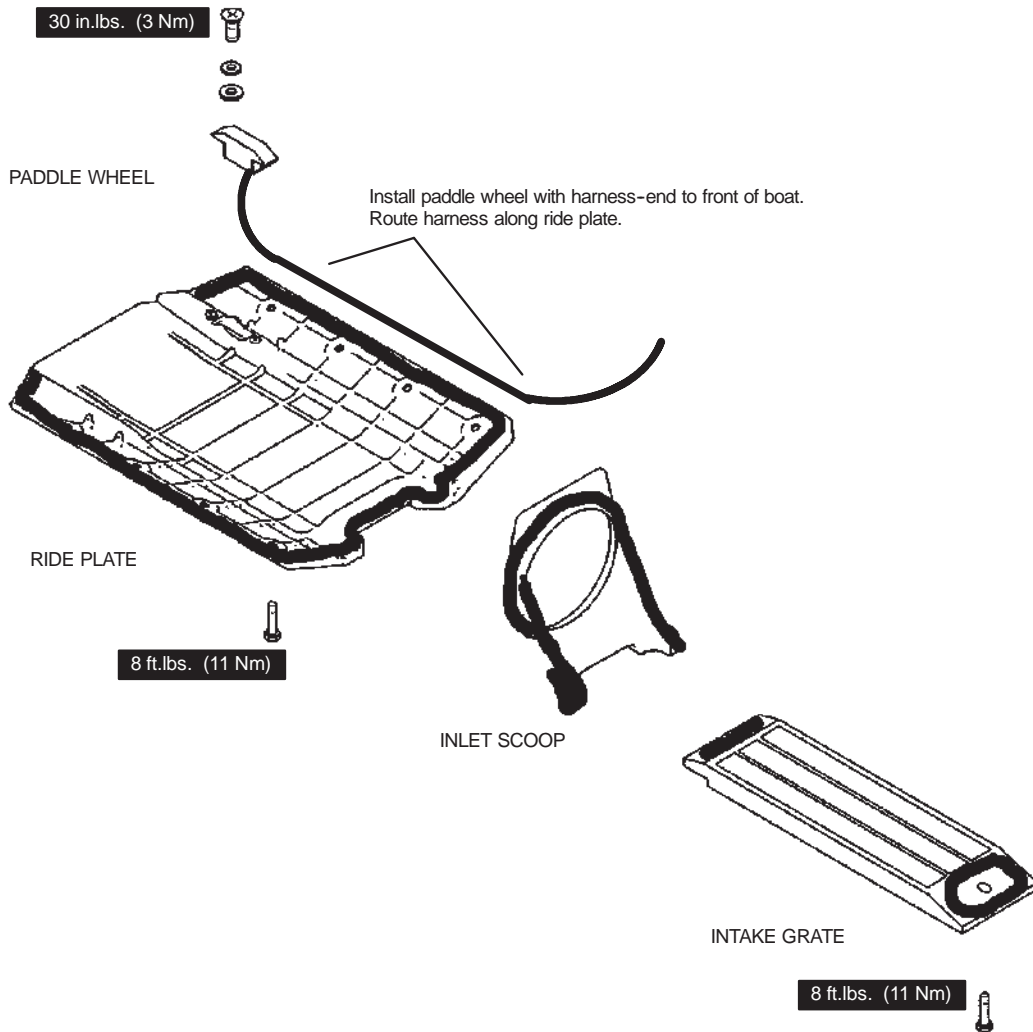

ASSEMBLY NOTES

Paddle Wheel Fastener Torque: 30 in.lbs. (3 Nm)
Paddle Wheel Thru-Hull Nut Torque: 25in.lbs. (2.8 Nm)
Ride Plate Fastener Torque: 8 ft.lbs. (11 Nm)
Intake Grate Fastener Torque: 8ft.lbs. (11Nm)

Apply continuous bead of marine-grade silicone to all mating surfaces of the hull, inlet scoop, front and sides of ride plate, and front and rear sections of inlet grate. Ventilation will occur if gaps are present at mating surfaces.

CAUTION: DO NOT ALLOW SILICONE TO ENTER WATER HOSE OR PIPE ORIFICES. SERIOUS ENGINE DAMAGE MAY OCCUR!

PROPULSION

▲ WARNING

Before working on the drive system, be sure the lanyard cord and lock plate are removed from the engine stop switch to kill the ignition or severe injury could result.

Pump Removal

1. Remove lanyard cord. Proceed with disconnecting the battery by removing negative(-) cable.
2. Disconnect reverse and steering linkage from nozzles. Discard cotter pin and nylock nuts.
3. Using a criss-cross pattern, remove the four (4) pump mounting bolts.
4. With the mounting bolts removed, each component can be removed from the assembly. These components are:
 - Steering nozzle w/reverse gate.
 - Stator assembly w/impeller.
 - Extension housing.

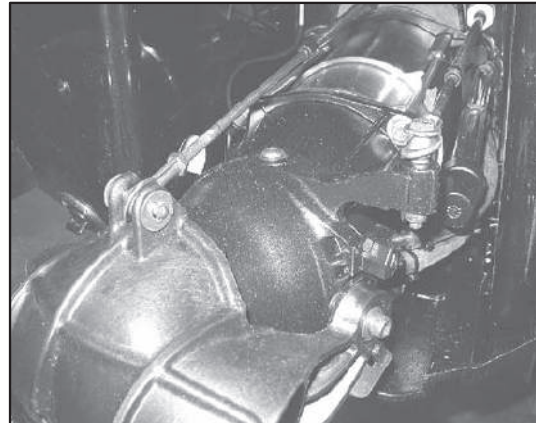

Pump Assembly

Pump assembly is the reversal of disassembly. Polaris recommends applying dielectric grease to all nozzle-to-nozzle mating surfaces to prevent corrosion.

Follow torque specifications listed on page 6.2.

NOTE: Always install new Nylock nuts and cotter pins.

Pump Housing Removal

1. Remove the pump components as described above.
2. Access the pump housing mounting bolts from inside the engine compartment. Remove the nuts, washers, and steering cable locking plate.
3. Attempt to remove the housing from the hull using a small prybar. Do not damage the pump housing or hull mating surfaces. If the housing will not come loose without excessive force, the ride plate and inlet grate must be removed from the hull.
4. Follow ride plate and inlet grate removal procedures outlined in this chapter if components require removal.
5. With components removed, re-attempt removing the housing.
6. Always use light force when using a prybar against the hull and housing mating surfaces.

Pump Housing Installation

The mating surfaces between the hull and pump housing must be cleaned prior to installing the housing. Clean surfaces with alcohol.

To install the housing, follow the procedures listed on page 5.15 and 5.16.

PROPULSION

Bearing Carrier Removal

The bearing carrier uses sealed bearings. Bearing maintenance or lubrication is not required.

1. From inside the engine compartment, remove the drive coupler guard.
2. Remove the pump assembly as outlined in the Pump Removal section.
3. Obtain strap wrench and driveshaft removal tool. Have an assistant secure the aft (Rear) drive coupler.
4. Using the driveshaft removal tool, PN PW-46593, carefully loosen the driveshaft from the coupler.
5. Carefully pull the driveshaft through the rear of the craft.
6. Loosen and remove the four (4) bearing carrier mounting bolts. Remove bearing carrier.

Bearing Carrier Installation

Installation is the reverse of removal with the following exceptions:

1. Begin the installation process by installing the aft (Rear) drive coupler. Press coupler firmly into rubber dampener.
2. Mount the bearing carrier to the hull loosely. DO NOT torque the mounting bolts at this time.
3. Carefully insert the driveshaft through the bearing carrier and engage the drive coupler.
4. Have an assistant hold the drive couplers.
5. Using the driveshaft removal tool, slowly install the driveshaft into the coupler. (A drill or air wrench can be used if set on lowest speed setting.)
6. Secure bearing carrier to hull. Follow torque specifications and sequence outlined on page 5.2.

PROPULSION

Driveshaft Shim Procedure

The driveshaft must be shimmed to prevent driveline damage.

NOTE: The NOMINAL number of shims = 2.

1. Install tapered spacer over driveshaft end. Verify beveled edge is flush with driveshaft bevel.
2. Install two shims, then hand thread coupler on to driveshaft.
3. Push couplers together with rubber dampener installed.
4. Measure "X" as outlined in illustration below.
5. Reference specification table and remove or add shims.

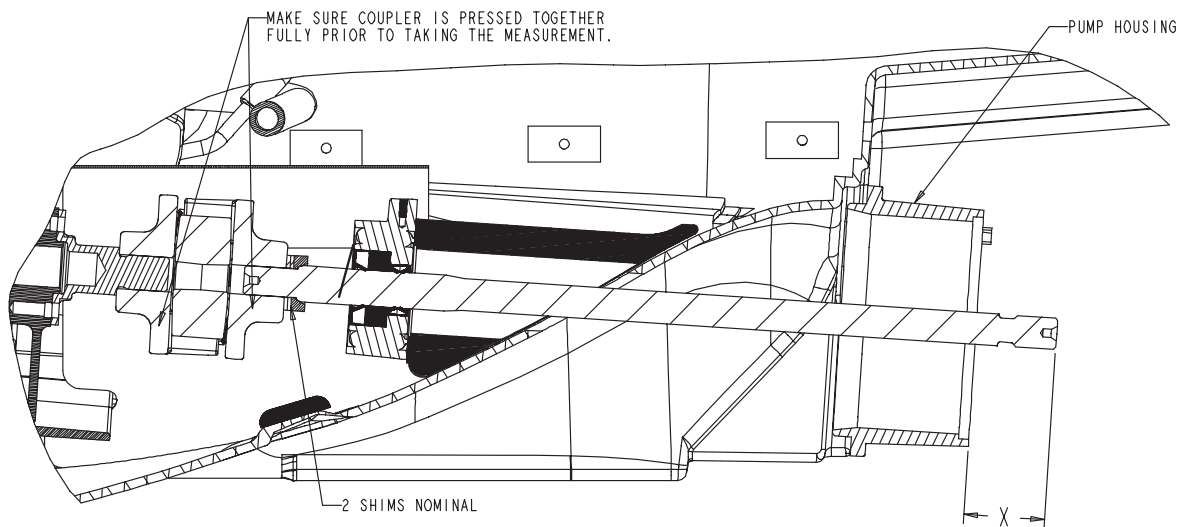

Pump Housing - To - End of Driveshaft (INCHES)	Number of Shims From NOMINAL	Total Number of Shims
$X < 2.110$	+2	4
$2.110 < X < 2.195$	+1	3
$2.195 < X < 2.280$	0	2
$2.280 < X < 2.365$	-1	1
$X > 2.365$	-2	0

PROPULSION

▲ WARNING

Before working on the drive system, be sure the lanyard cord and lock plate are removed from the engine stop switch to kill the ignition or severe injury could result.

Impeller Clearance

1. Remove lanyard cord and lock plate from engine stop switch. Disconnect battery ground (-) cable.
2. Remove intake grate and check impeller to housing clearance with a feeler gauge. Measure clearance at leading edge, middle, and trailing edge of each blade. Replace impeller if clearance exceeds service limit at any point. If clearance exceeds service limit with a new impeller, replace pump housing.

Impeller Clearance

Std: .002 - .008" (.05 - .20 mm)
Service Limit: .020" (.5 mm)

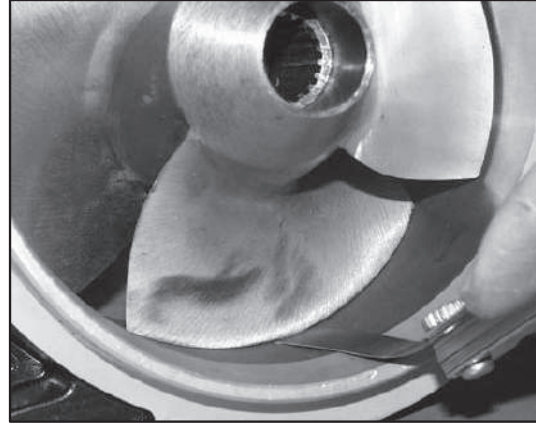

Drive Shaft Inspection

1. Clean driveshaft and support in V - blocks as shown (C). Measure runout by rotating shaft and observing dial indicator at point (B). Replace if runout exceeds the service limit.

NOTE: Excessive driveshaft runout can cause vibration, bearing, and spline failure. See Pump/Final Drive Troubleshooting at the end of chapter 2.

Drive Shaft Runout

Service Limit: .005" (.13mm)

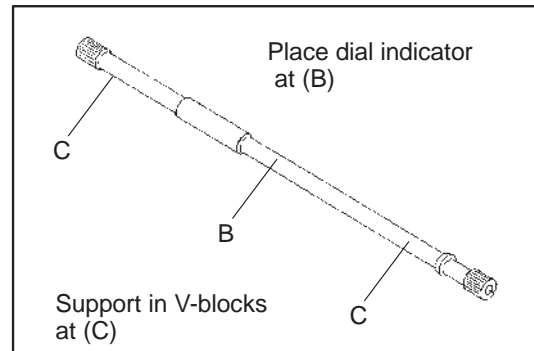

2. Inspect driveshaft splines and threads inside engine drive coupler and impeller carefully for wear or damage. Replace worn parts. Rubber bumpers control driveshaft end play. Replace if worn, cracked or damaged.

NOTE: If driveshaft, impeller, or coupler threads are worn or damaged, improper pump-to-hull, or pump-to-engine alignment should be suspected. Refer to Pump/Drive shaft Alignment on pages 5.13 - 5.14 for more information.

Drive Shaft End Play

.100-.200" (2.54-5.08mm)

PROPULSION

Stator Disassembly

1. Remove tail cone screws (3) and tail cone. Inspect O-ring seal located behind tail cone. Replace seal if damage is evident.

NOTE:

When removing tail cone, hold stator with cone pointed down. Twist cone off. This will allow any water from entering the impeller assembly. It is normal for a small amount of water to be inside the cone during operation.

2. Mount stub shaft flat surfaces in a vise to prevent the impeller and stator from rotating.

3. Install impeller removal tool and turn counterclockwise to remove. The impeller removal tool can be identified by (3) knurled sections on the shaft.

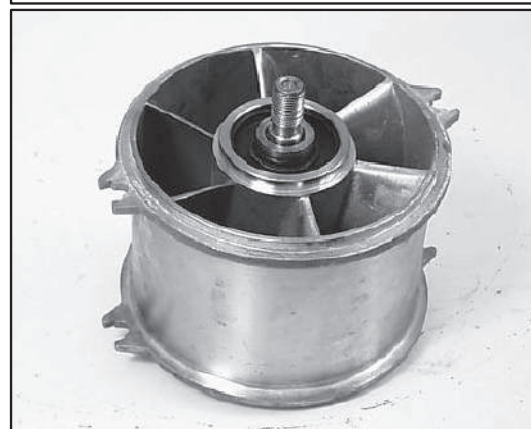
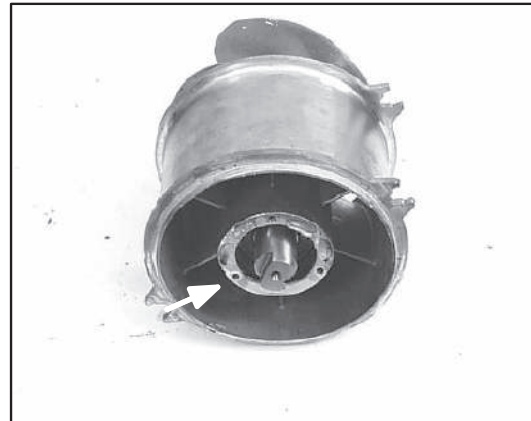

Impeller Removal Tool
PN 2871036



Impeller Removal Tool
has 3 knurled sections

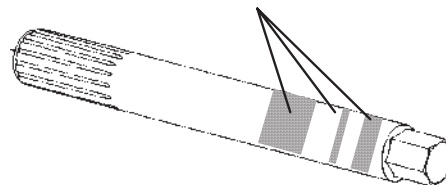

Impeller Tool Diameter:
.852" (21.65mm)

PROPULSION

Stator Disassembly - Continued

4. Remove stator assembly from vise. Using a soft-faced hammer, tap stub shaft out of housing.
5. Inspect shaft and collar for wear, scratches, or damage. Install new o-rings upon reassembly.

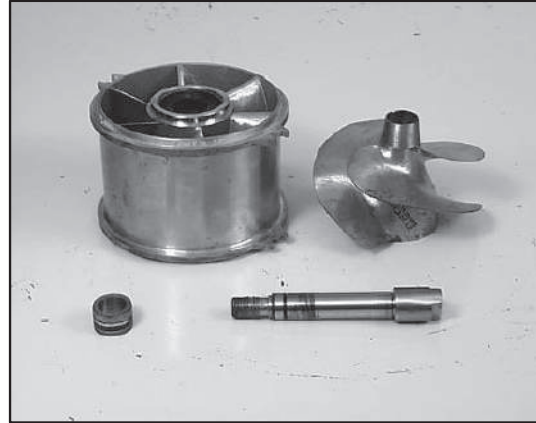

6. Using a brass hammer or aluminum drift, tap bearing spacer to one side of the stator housing. Drive out bearings by tapping on inner races.

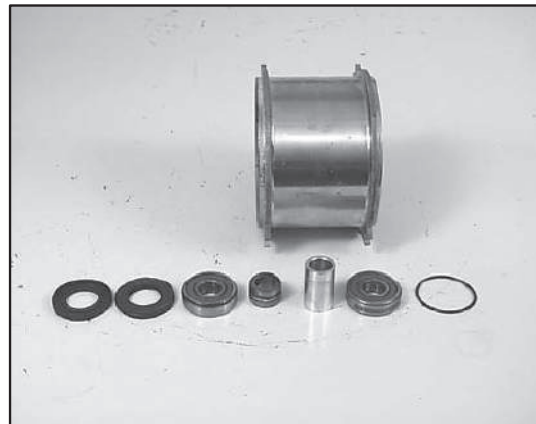

7. Measure spacer with a Vernier caliper. Replace if worn beyond service limit. If the spacer is too short, the bearings will be side-loaded and premature wear will result.

Bearing Spacer Length
Service Limit: 1.730" (43.94 mm)

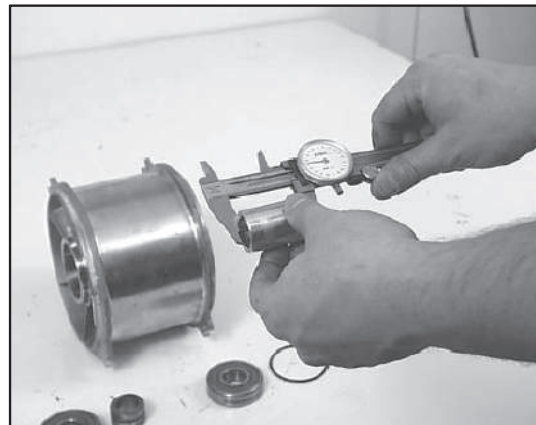

PROPULSION

Stator Assembly

NOTE: Seals, bearings, and o-rings should be replaced if removed. Heat the impeller housing evenly with a heat gun to ease removal of bearings in next step. Remove tail cone O-ring before applying heat. To ease installation, wrap bearings in wax paper and chill in a freezer for 30 minutes or longer. Warm the impeller housing evenly with a heat gun or a propane torch. **DO NOT OVERHEAT.**

1. Press or drive bottom bearing into place until it bottoms against the shoulder in the pump housing. Apply grease to center bearing spacer and install. Verify that bearing spacer is centered, and install second bearing.

CAUTION:

Do not drive on the inner race. Bearing damage will result. Drive on outer race only.

2. Place impeller spacer onto inner race of front bearing.



3. Apply marine grease to seal lips and also between the two seals. Install two new oil seals over impeller spacer with lips up and visible (toward impeller). Press seals to bottom of chamfer on seal bore (about 1/8" / .32 cm beyond end of bore).

WARNING: Never allow the impeller spacer to push up through the two seals when inserting the stub shaft. If spacer pushes through seals, the seal lips will be compromised and allow water into bearing housing.



4. Grease and install two new O-rings on stub shaft. Mount stub shaft flats in a vise. Grasp stator assembly with thumbs over impeller spacer. Carefully lower assembly over stub shaft. Verify that stub shaft has not pushed impeller spacer up through seals.

NOTE: If impeller spacer has pushed up through seals, push into place slowly and carefully to prevent dislodging seal springs.

5. Hand thread impeller onto stub shaft. Torque to specifications. Rotate impeller by hand to insure proper rotation.



Impeller Torque
100 ft. lbs. (138 Nm)
Apply Loctite™ 242 to threads.

PROPULSION

Driveshaft Alignment

1. Disconnect the NEGATIVE (-) first, then POSITIVE (+) battery cables from the battery. DO NOT PROCEED WITHOUT PERFORMING STEP 1!
2. Remove coupler guard.

(Illustration 1)

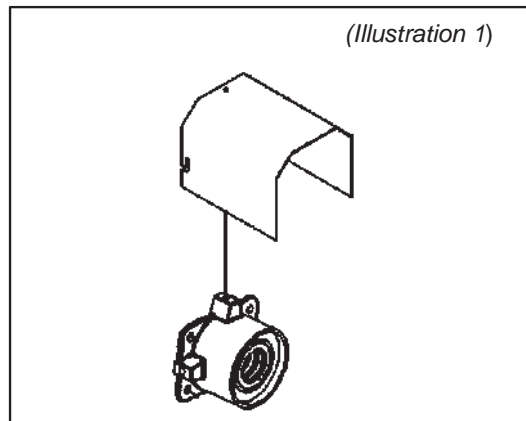

3. Remove the reverse cable and steering cable linkage from the pump. (Photo A) Discard all Nylok™ nuts. Remove the four pump mounting bolts that mount the pump sections to the pump housing. Remove the pump sections.
4. Back-up the drive couplers using a large pipe wrench or strap wrench and remove the driveshaft using the DRIVESHAFT REMOVAL / INSTALLATION TOOL, PN PW-46593. Remove the driveshaft from the watercraft.

NOTE: Do not damage the drive coupler fingers.

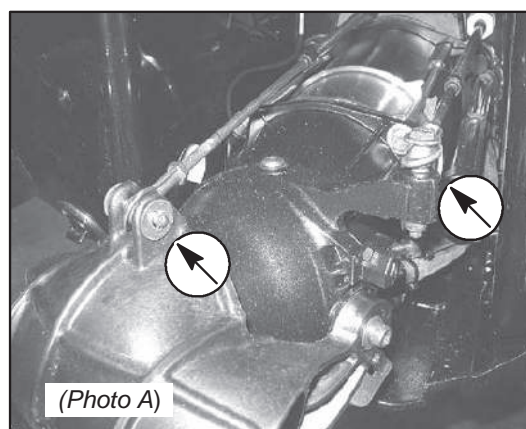

(Photo A)

5. Remove the bearing carrier from the pump box. (Illustration 2)
6. Install a small dowel or socket extension into the PTO balance plate hole.
7. Rotate engine until dowel or extension jams against crankcase mounts.

(Illustration 2)

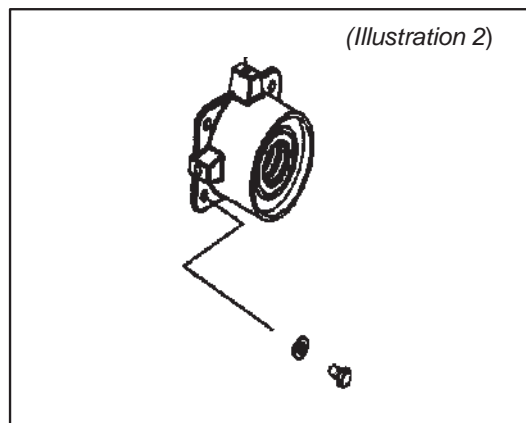

PROPULSION

Driveshaft Alignment

- Remove the pump-side drive coupler and rubber dampener. Using a pipe wrench or strap wrench, carefully remove the engine-side drive coupler. (*Illustration 3*)

NOTE: Do not damage the fingers on the drive coupler.

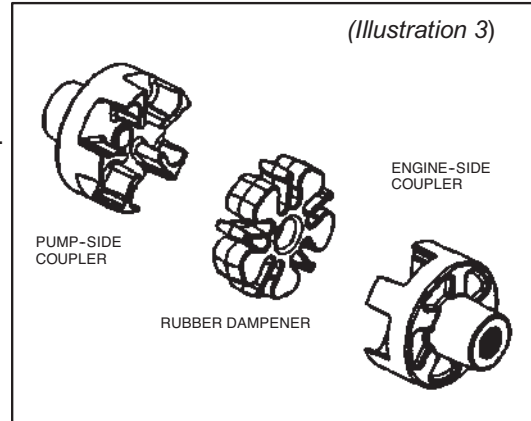

- Install the DRIVESHAFT ALIGNMENT COUPLER TOOL, PN PW-46592, on the PTO end of the crankshaft. Hand tighten tool.
- Locate the pump stator assembly. Remove the tail cone from the assembly. Discard the gasket and o-ring.

NOTE: Steps 11, 12, and 13 are only required if you do not have an "extra" Polaris pump stator already setup with bearings available.

If you already have a stator setup to perform alignment checks, proceed with STEP 15.

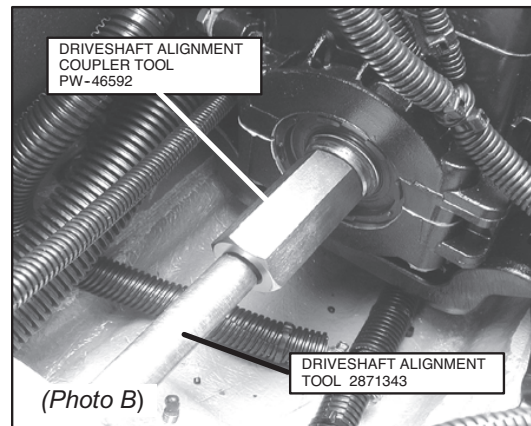

- Mount the stub shaft flats in a vice. Using the IMPELLER REMOVAL TOOL, PN 2871036, remove the impeller from the pump stator assembly. (*Photo C*)
- Carefully lift the pump stator assembly up and off of the stub shaft while the stub shaft is still secured in the vice.

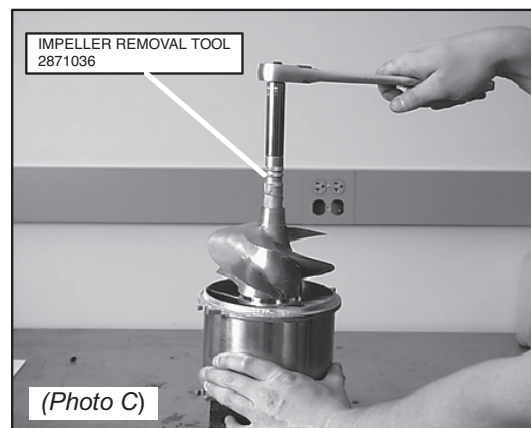

PROPULSION

Driveshaft Alignment - All Models

- Carefully insert the tapered-end of the PUMP ALIGNMENT TOOL, PN 2871343, through the pump stator. Securely mount the pump stator to the pump housing. (Photo D)

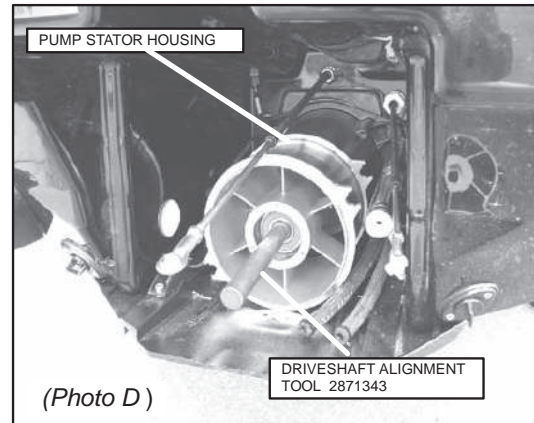

- THE TAPERED END MUST FIT EASILY INTO THE BORE USING LIGHT PUSHING FORCE. THE SHAFT MUST FULLY ENGAGE AND HIT THE CRANKSHAFT END. (Photo E)

If the Driveshaft Alignment Tool slides in and out of the Driveshaft Alignment Coupler Tool as outlined in STEP 16, adjustments to the engine strap mounting shims ARE NOT REQUIRED.

In this case, remove the tools and proceed with the REASSEMBLY PROCEDURES.

In the case where the Driveshaft Alignment Tool DOES NOT fit into the Driveshaft Alignment Coupler Tool as outlined in STEP 16; proceed with the ALIGNMENT PROCEDURE.

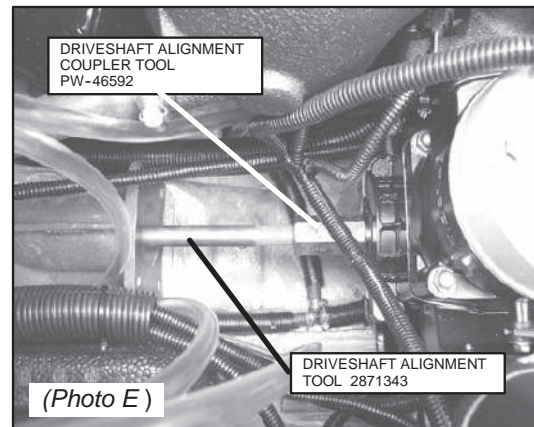

PROPULSION

Driveshaft Alignment Procedure

1. Reference the illustrations below. Loosen one engine mounting nut at a time, add or subtract shims, and re-check alignment.
2. Obtain new alignment shims, PN 5246894

NOTE: Always remember to torque mounting nuts to APPROXIMATELY 10 ft.lbs. to obtain an accurate alignment.

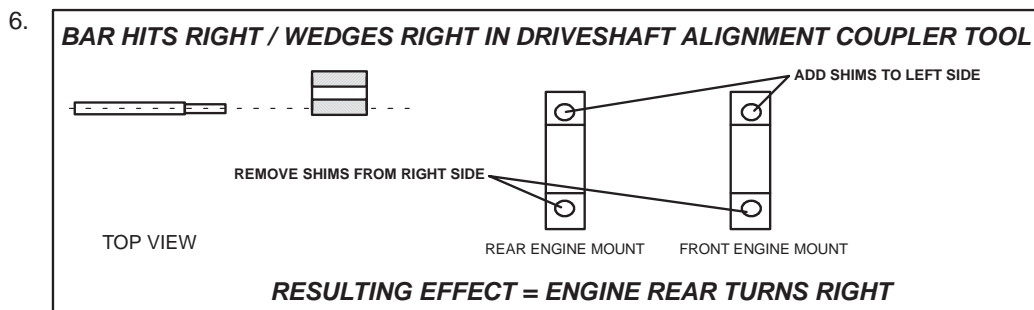
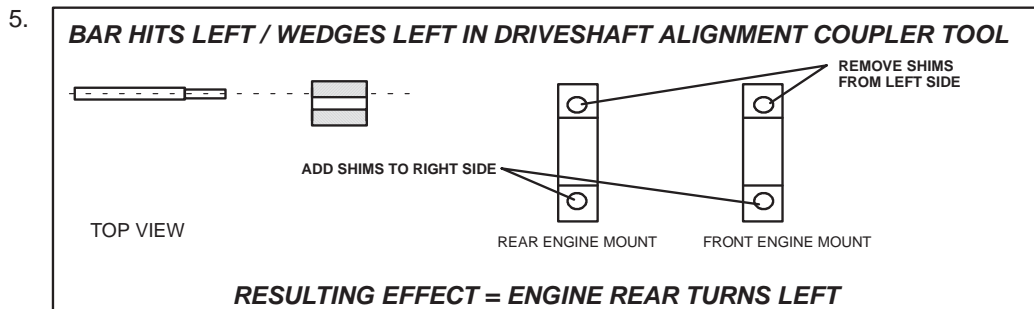
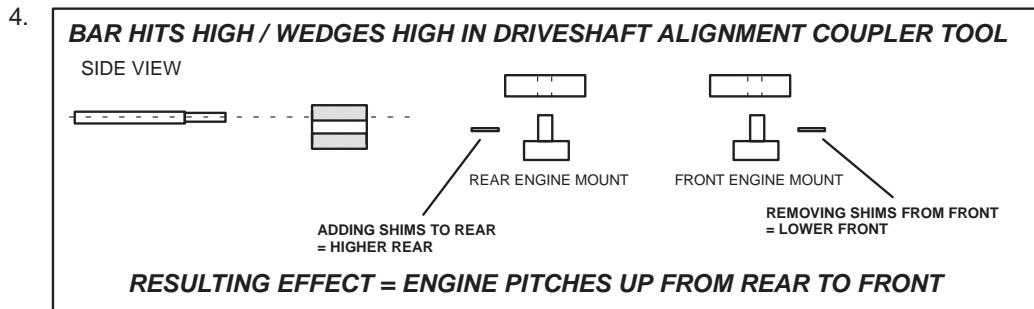
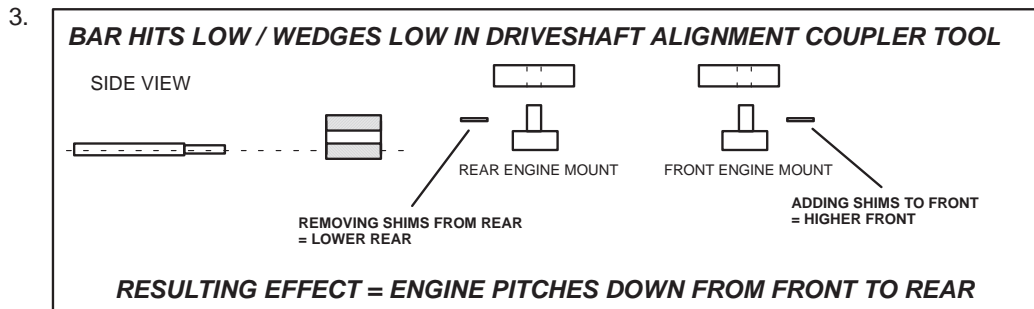

PROPULSION

REASSEMBLY PROCEDURE

1. Apply Loctite™ 262 to engine mount bolt threads. Torque engine mount nuts to 50 ft.lbs. (68 Nm)
2. Remove Driveshaft Alignment Tool and Driveshaft Alignment Coupler Tool.
3. Obtain the engine-side drive coupler. Apply a thin film of Premium Grease, PN 2871322, to the inner threads. Hand-tighten coupler on to crankshaft.
4. Insert rubber dampener into engine-side drive coupler.
5. Insert pump-side drive coupler into rubber dampener. Apply light film of Premium Grease to inner threads.
6. Have an assistant insert driveshaft through rear of boat. As driveshaft enters engine compartment, carefully fit bearing carrier on to front of shaft. (*A light film of grease will aid in installation.*)
7. Install thrust washer, and two shim washers over front of driveshaft after it has passed through the bearing carrier. (*The beveled side MUST fit flush with driveshaft bevel.*) (Illustration 4)
8. Guide the front of the driveshaft into the drive coupler end. Have an assistant insert and screw driveshaft into the drive coupler from the rear of the boat. Keep the beveled end of the thrust washer flush with the beveled end of the driveshaft as the shaft is being screwed into the coupler.
9. Perform the DRIVESHAFT SHIM PROCEDURE outlined on page 6.10.
10. Once driveshaft is screwed into coupler, push the bearing carrier back against the pump wall. Do not install the mounting screws at this time.
11. If the impeller was removed from the pump stator, the assembly will have to be re-built with new seals, and o-rings.
12. Reassemble the pump sections to the pump housing. Apply a light film of grease to the pump section mating surfaces.
13. Install the four pump mounting bolts. Tighten to 2 ft.lbs. (2.7 Nm) in a criss-cross pattern. Torque bolts to 14 ft.lbs. (19 Nm), following the same criss-cross pattern.
14. Mount the bearing carrier to the pump wall. Torque the bearing carrier screws to 14 ft.lbs. (19 Nm) using a criss-cross pattern.
15. Re-install the coupler guard. Apply Loctite™ 242 to screws and torque to 35 in.lbs. (3.9 Nm)
16. Re-install the two siphon hoses to the pump nozzle. Use new panduit straps to secure hoses.
17. Re-install the reverse linkage retaining pin using a new cotter pin.
18. Using a new Nylok™ nut, re-install the steering cable rod-end linkage. Apply Loctite™ 242 to screw threads and torque nut to 8 ft.lbs. (11 Nm)
19. Apply liberal amounts of Nyogel™ to battery terminals and re-install the POSITIVE (+) lead first, then NEGATIVE (-) lead to the battery.
20. Re-install the PTO spark plug. Torque plug to 18 ft.lbs. (24 Nm)

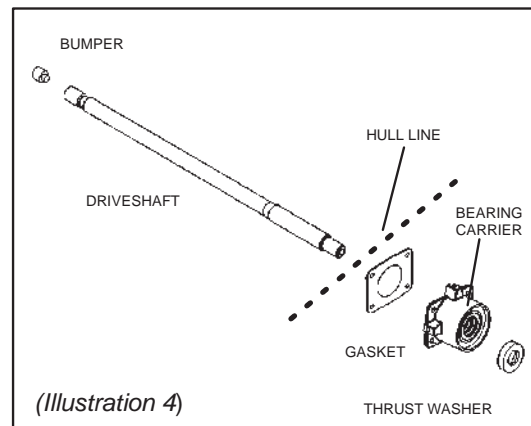

PROPULSION

Sacrificial Anode

A zinc sacrificial anode is in place on all models on the pump housing. The purpose of the anode is to prevent corrosion of metal parts due to electrolysis. The mounting surfaces must be clean and the mounting bolt tight to maintain a good connection between the pump and anode.

1. Periodically inspect anode for excessive wear.
2. Check bolt to be sure it is tight. If the bolt is loose, remove anode and clean mounting surfaces on pump and anode.
3. Apply dielectric grease to bolt threads and contact surfaces.
4. Tighten bolt securely.

NOTE: During preventative maintenance, verify that the anode is tightened securely to the pump housing. Replace sacrificial anode whenever anode shows signs of erosion.

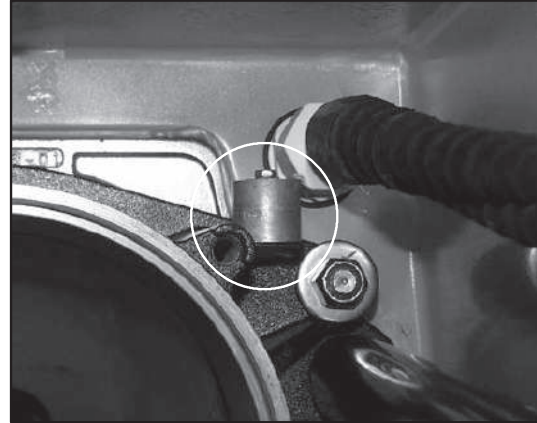

**Sacrificial Anode Bolt Torque
25in.lbs. (2.9Nm)**

PROPULSION

Intake Scoop / Ride Plate Removal and Installation

Removal

1. Remove pump assembly as outlined on pages 5.10 to 5.12.
1. Remove the inlet grate and ride plate mounting bolts.
2. Insert a length of 2x4 wood through the water inlet housing from the rear of the watercraft. Rest the 2x4 on top of the ride plate.
3. Using your foot, apply downward force to the 2x4. This will remove the ride plate from the hull along with the inlet grate.
4. Remove the pump mount assembly by removing the 4 mounting nuts from inside the hull. Gently pry the pump mount assembly from the hull.
5. Using the same method, remove the inlet scoop.

WARNING: Some inlet scoops are made of plastic. Use less force when removing.

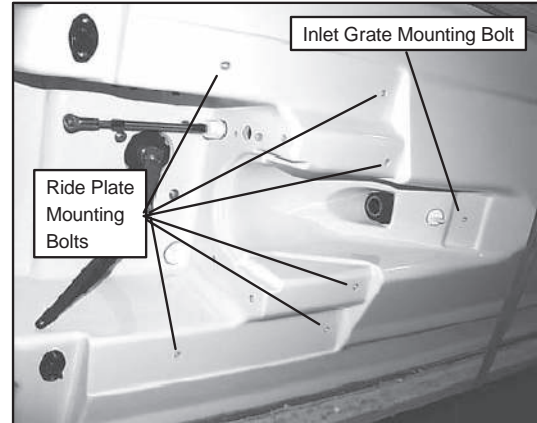

Installation

1. Begin the installation process by removing all silicone from the ride plate, inlet scoop, pump mount assembly, and inlet grate mating surfaces.
2. Prepare mating surfaces by wiping surfaces down with isopropyl alcohol or acetone.

WARNING: All silicone residue and must be removed prior to reassembly. All mating surfaces must be cleaned with isopropyl alcohol or acetone. One the installation has begun, it must be finished quickly due to the silicone curing time. Never leave your work during this process. Do not allow silicone to sit open for longer than 4 minutes with out attaching a component.

3. Apply continuous bead of marine grade silicone to all mating surfaces of the hull, scoop, front and side edges of ride plate, and front and rear sections of the inlet grate. PN 8560054. Cavitation may occur if silicone is not continuously applied.

**Marine Grade Silicone
PN 8560054**

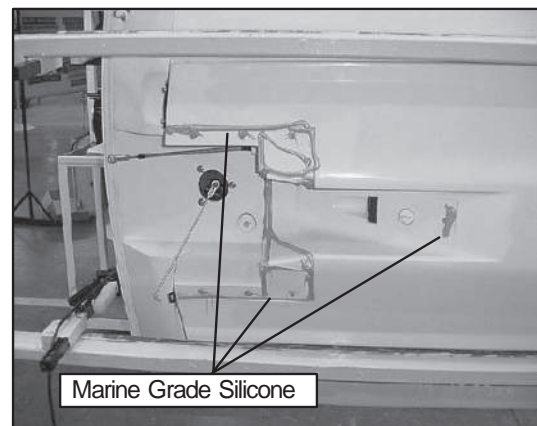

PROPULSION

Intake Scoop / Ride Plate Removal and Installation - Continued

1. Insert inlet scoop into pump cavity. Apply marine grade silicone to scoop / ride plate mating surface.

Marine Grade Silicone
PN 8560054

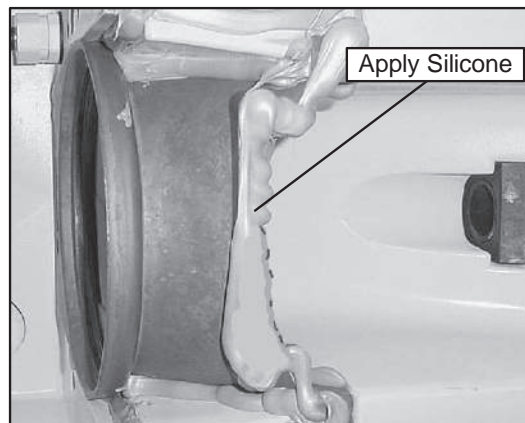

2. Apply marine grade silicone to pump mount assembly, and inlet scoop to pump mount mating surface.

WARNING: Do not allow silicone to enter the water inlet pipe or bilge siphon inlet. Severe engine damage may occur if the water inlet pipe is obstructed.

3. Attach pump mount to hull.

Pump Assembly Mounting Nuts
28ft.lbs. (39Nm)
Apply anti-seize lubricant to threads.
Use criss-cross pattern when fastening.

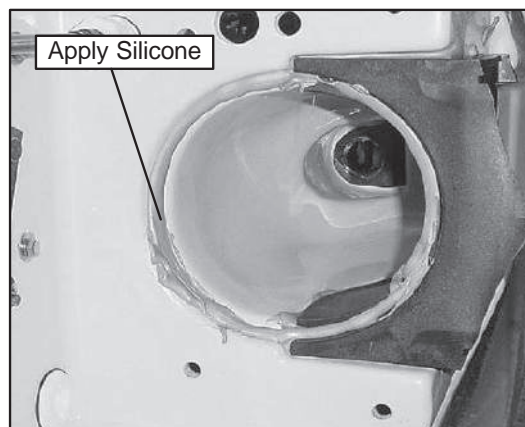

4. Attach inlet grate to hull. Loosely thread the inlet grate mounting bolt.
5. Apply a layer of silicone to the inlet grate tab that fits into the ride plate.
6. Attach the ride plate to the hull. Loosely thread mounting bolts from front to back in a criss-cross pattern.

Inlet Grate Mounting Bolt: 8ft.lbs. (11Nm)
Apply Loctite™ 242 to threads
Ride Plate Mounting Bolts: 8ft.lbs. (11Nm)
Apply Loctite™ 242 to threads.

NOTE: Wipe off all excess silicone away from components. Allow 24 hours before operating watercraft to allow silicone to cure.

Marine Grade Silicone
PN 8560054

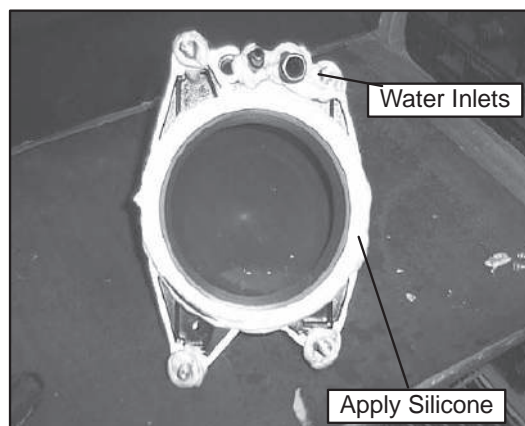



POLARIS[®] *WATERCRAFT*

MSX 110 / 150 Service Manual

Hull and Body

Hull Specifications / Paint Codes	7.1
Fastener Guide	7.2
Steering / Reverse Cable Routing	7.3
Siphon Hose Routing	7.4
Hull Assembly Illustration	7.5 - 7.6
Compartment Door Assembly	7.7
Shroud and Storage Assemblies	7.8
Seat Assembly	7.9
Steering Control Assembly	7.10
E.S.P. Switch Assembly	7.11
PPU Assembly	7.12
Reverse System Assembly	7.13
Handlebar / Steering Post Removal	7.14
Steering Cable Removal and Installation	7.15 - 7.16
Steering / Reverse Cable Adjustment	7.17
Top Deck / Hull Repair	7.18

HULL AND BODY

Hull Specifications

	MSX 110	MSX 150
Hull Design	Modified - V Progressive Dihedral Stepped	
Hull Material / Process	Fiberglass Reinforced Compound (FRC)	
Top Deck Material / Process		

Paint Codes / Colors

	Paint Numbers*	
	MSX 110	MSX 150
Hood / Shroud / Glove Box	A - P292 B - P443 C - P465	A - P441 B - P444 C - P445 D - P464
Top Deck	P207	P403
Hull		P070
Footwell Pads	P318	

* Polaris paints can only be ordered through the an authorized Polaris dealership.

- P070 BLACK
- P207 WHITE
- P292 HAVASU RED
- P318 CHARCOAL
- P403 MATRIX SILVER ALLOY
- P441 CATALINA BLUE C;EAR METALLIC
- P443 SARASOTA YELLOW CLEAR METALLIC
- P444 SOLAR RED CLEAR METALLIC
- P445 TURBO SILVER CLEAR METALLIC
- P464 STEALTH BLACK
- P465 BIONIC COPPER CLEAR METALLIC

CAUTION: Prior to reassembling certain parts of the hull and body, note whether the use of Loctite™ thread locking agent is authorized. Some hull and body parts cannot not come into contact with Loctite™ thread locking products.

HULL AND BODY

Fastener Guide - Hull / Control Systems

HULL / BODY			
Where Used	Torque		Remarks
	FT.LBS	Nm	
LH & RH / Upper Console Shrouds	23	31	
Console Shroud Assembly - To - Top Deck	5	7	
Mesh Screens	10 (In.Lbs.)	1	
Windscreen	22 (In.Lbs.)	2.5	
Splash Guard	40 (In.Lbs.)	4.5	
Compartment Door-To-Hinge	40 (In.Lbs.)	4.5	
Top Deck-To-Hinge Assembly	14	19	
Compartment Door Plunger Base	8	11	
Grab Rail	10	4	
Bilge Plugs	8 - 10 (In.Lbs.)	1	
Rub Rail Inserts	25 (In.Lbs.)	2.8	
Front Bumper	25 (In.Lbs.)	2.8	
Sponsons	70 (In.Lbs.)	6	Apply Marine-Grade Silicone to Holes.
Rub Rails	25 (In.Lbs.)	2.8	
Gauge-To-Door Fasteners	14 (In.Lbs.)	1.5	
Seat Post Latch	41 - 57 (In. Lbs.)	4.5 - 6	
Rear Seat Plunger Nut	18	11	Apply Loctite™ 262.
Seat U-Bolt Nuts	8	11	Apply Loctite™ 262.
Mirrors	22 (In.Lbs.)	2.5	
STEERING SYSTEM / HANDLEBAR ASSEMBLY			
Handlebar Cover / Pad	20 (In. Lbs.)	2	
Steering Housing -To- Top Deck	14	19	
Steering Cable Adjuster Clamp	8	11	Apply Loctite™ 242.
Steering Arm Clamp	8	11	Apply Loctite™ 242.
Throttle Block	20 (In.Lbs.)	2	
Rod End -To - Nozzle	8	11	Apply Loctite™ 242.
Handlebar Grab Handle	35 (In.Lbs.)	4	
Rod End - To - Steering Arm Clamp	8	11	
ESP Cam	5	7	Apply Loctite™ 242.
REVERSE MECHANISM ASSEMBLY			
Reverse Assembly -To - Top Deck	6	8	
Reverse Cable Retainer Plate	22 (In.lbs.)	2.5	
Reverse Arm	40 (In.lbs.)	4.5	
Reverse Cable Thru-Hull Lock Nut	16	21	Apply Loctite™ 242.
Reverse Cable Jam Nut	40 (In.Lbs.)	4.5	Apply Loctite™ 242.
Reverse Gate Pivot Fasteners	14	19	Apply Loctite™ 242.

HULL AND BODY

Steering Cable Routing

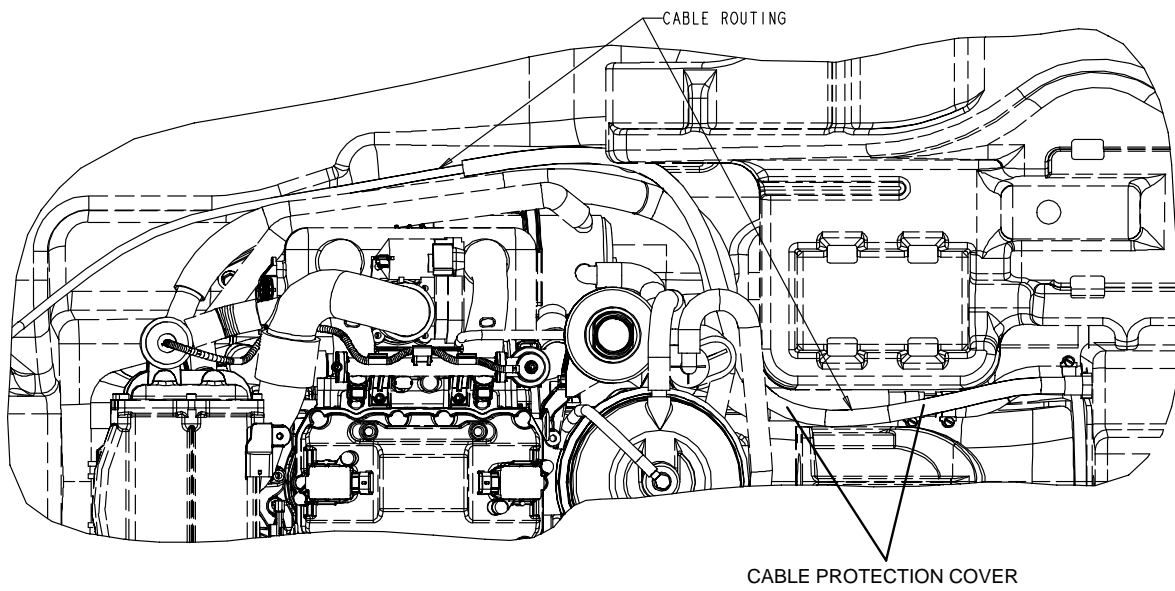

Reverse Cable Routing

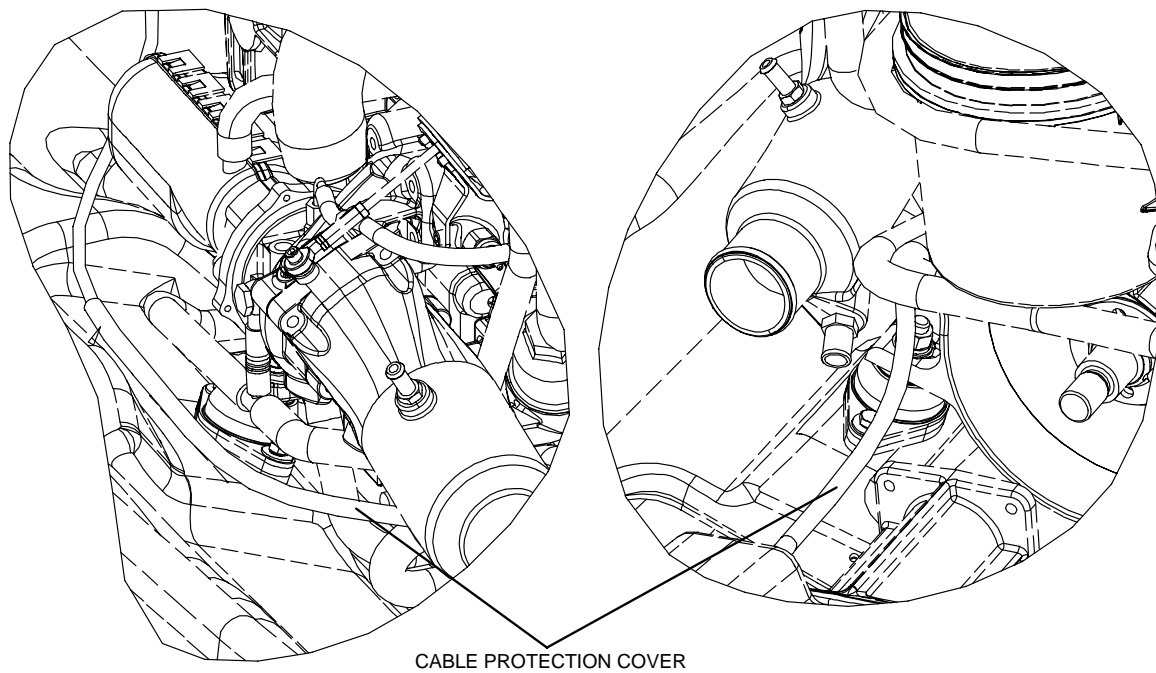

HULL AND BODY

Siphon Hose Routings

SECURE WITH ZIP TIES

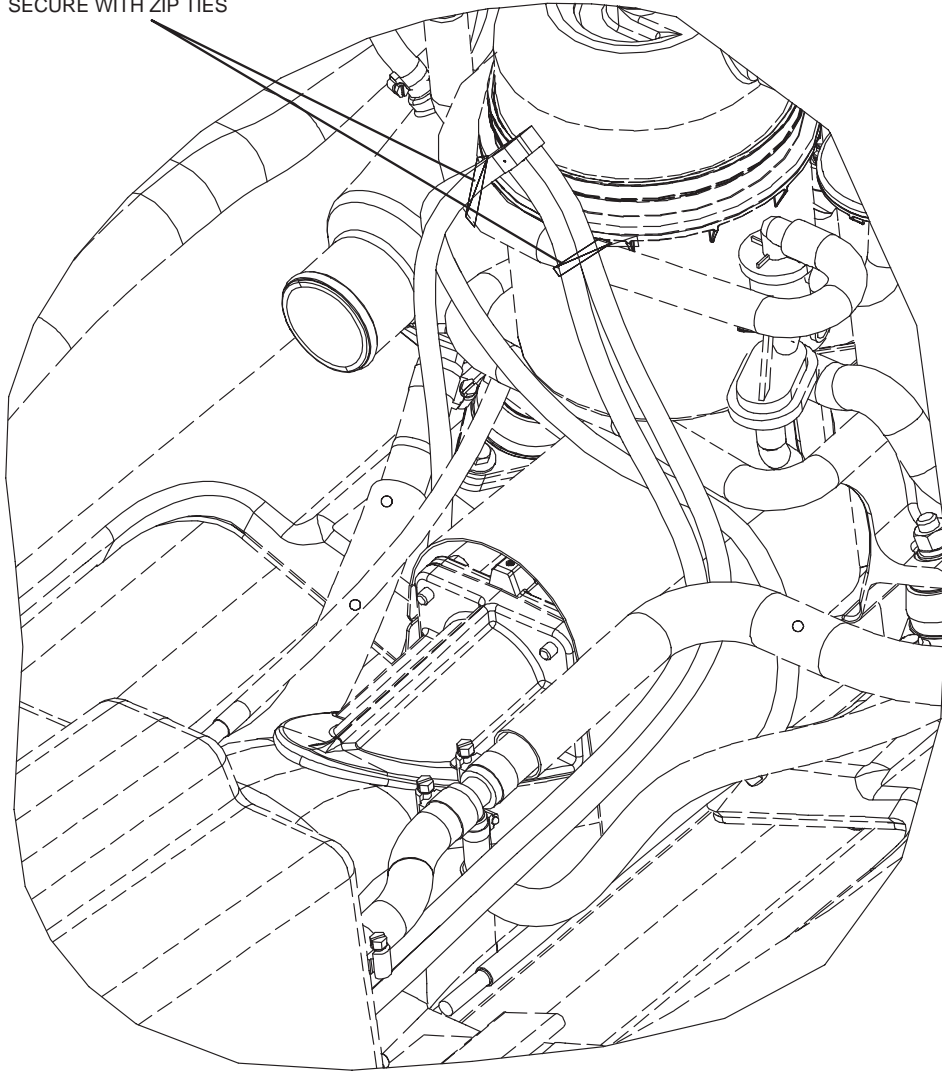

HULL AND BODY

Hull Assembly

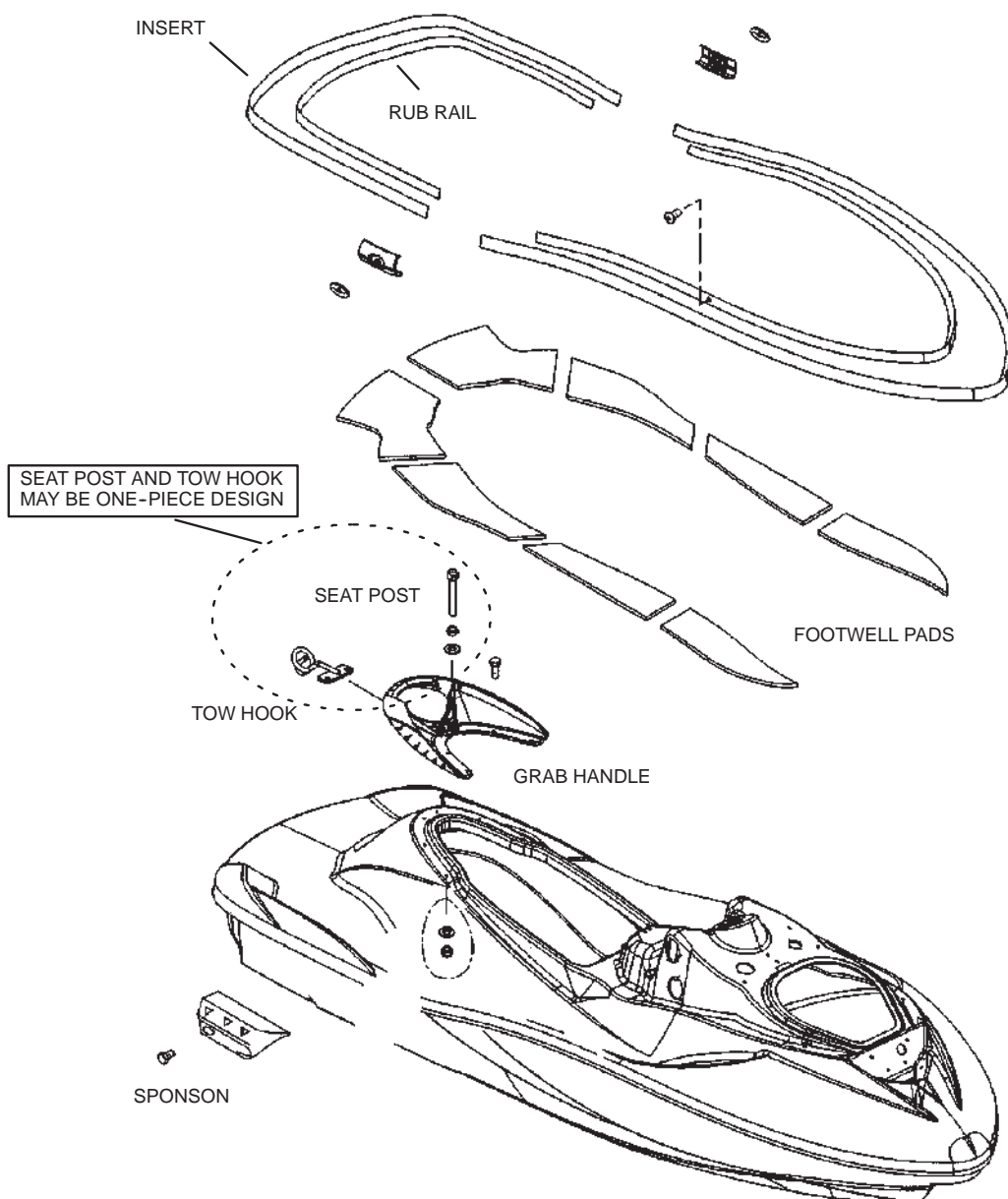

HULL ASSEMBLY NOTES

Rub Rail Fastener Torque: 25 in.lbs. (2.8 Nm)
Rub Rail Insert Fastener Torque: 25 in.lbs. (2.8 Nm)
Bumper Fastener Torque: 25 in.lbs. (2.8 Nm)
Grab Handle Bolt Torque: 10 ft.lbs. (4 Nm)
Seat Post Plunger Nut Torque: 18 ft.lbs. (25 Nm) .
Sponson Fastener Torque: 70 in.lbs. (6 Nm) Apply marine grade silicone to holes.

HULL AND BODY

Hull Assembly - Continued

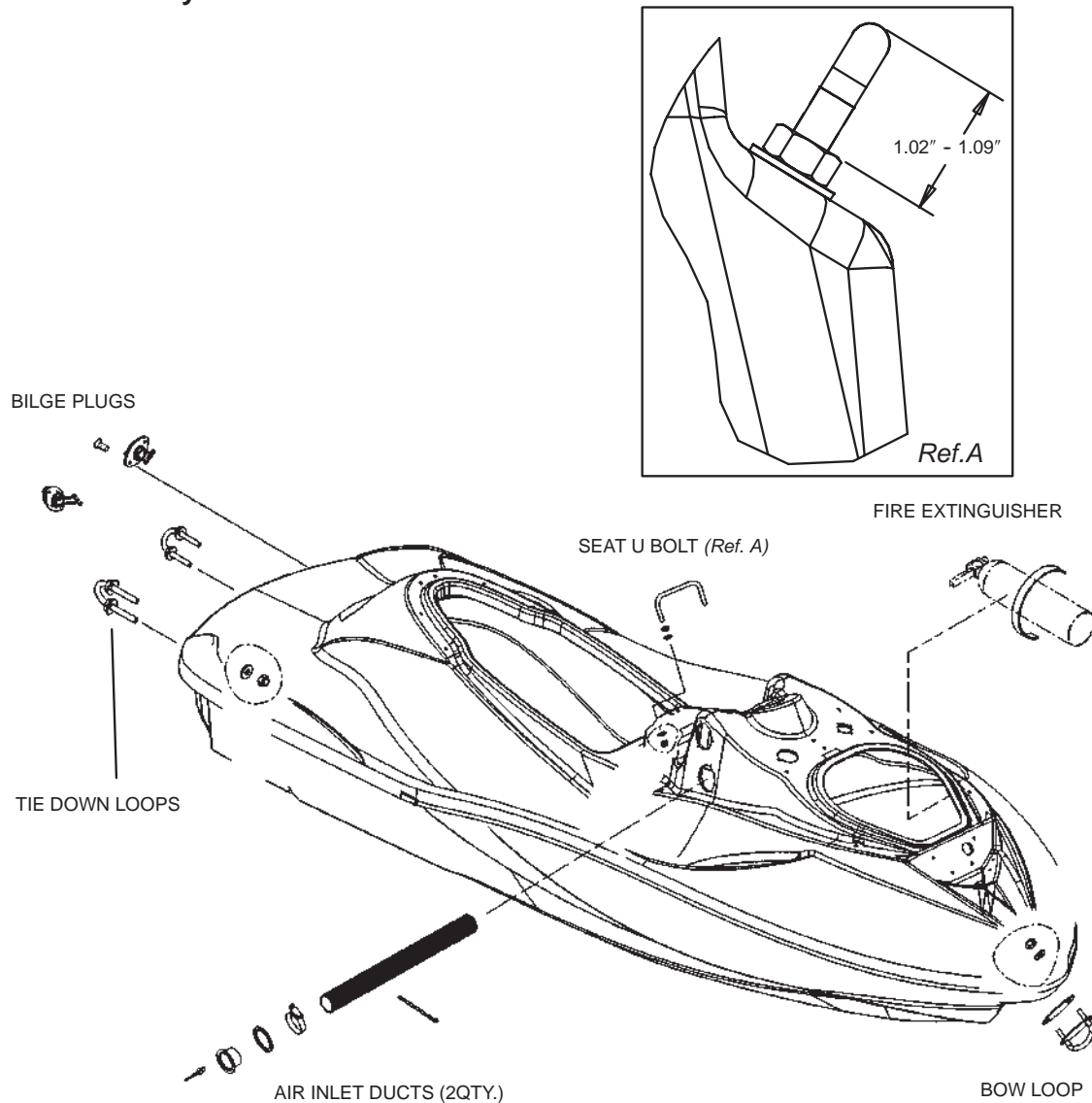

HULL ASSEMBLY NOTES

Bilge Plug Fastener Torque: 8 - 10 in.lbs. (1 Nm)
Tie Down Loop Torque: 8 ft.lbs. (11 Nm)
Bow Loop Nuts: 8 ft.lbs. (11 Nm)
Seat U Bolt Nuts: 8 ft.lbs. 11 Nm
Worm Gear Clamp Torque: 25 In.lbs. (2.8 Nm)
Apply Loctite 242™ to all threaded fasteners. (THIS PAGE ONLY)

HULL AND BODY

Compartment Door Assembly

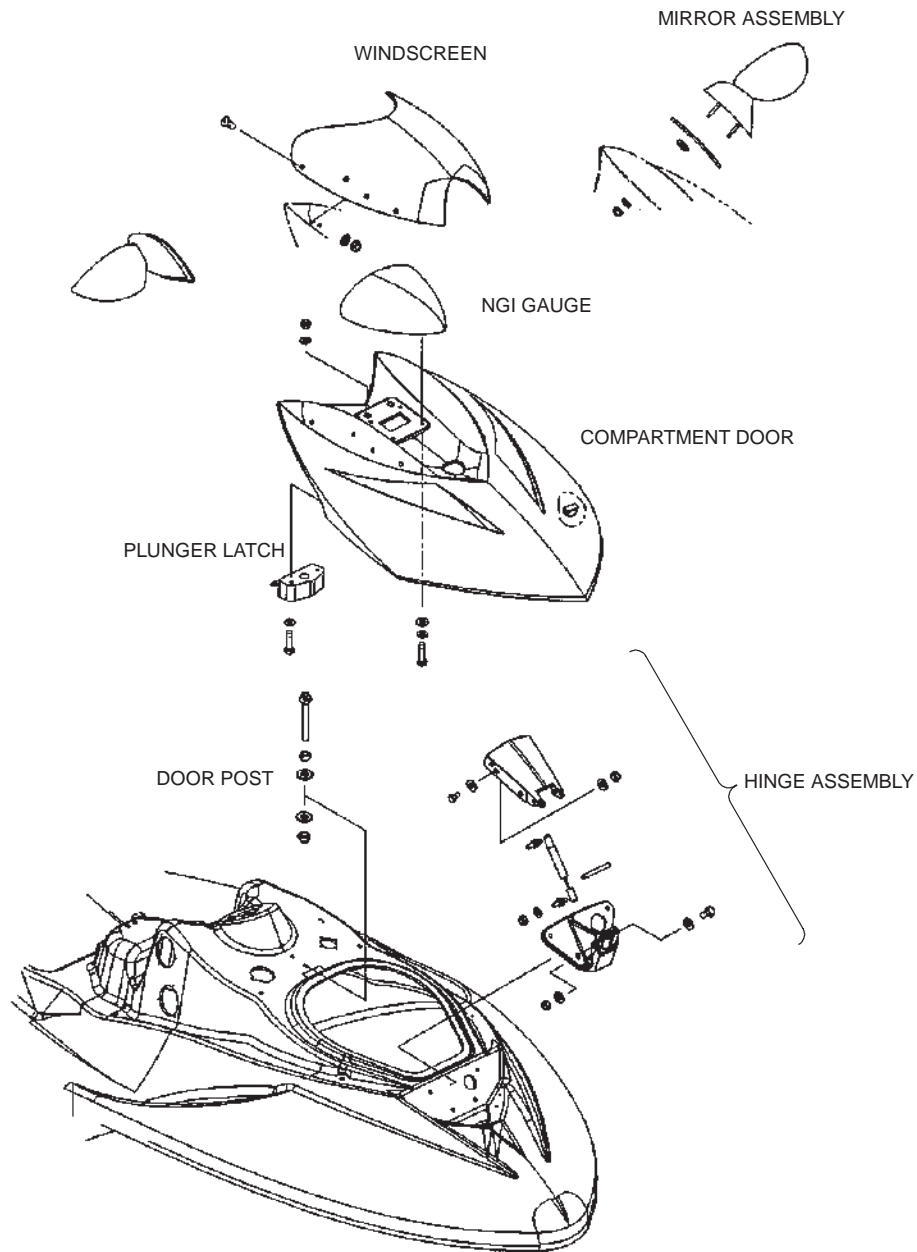

COMPARTMENT DOOR ASSEMBLY NOTES

Mirror Nut Torque: 22 in.lbs. (2.5 Nm)
Windscreen Bolt Torque: 22 in.lbs. (2.5 Nm)
NGI Gauge Bolt Torque: 14 in.lbs. (1.5 Nm)
Plunger Latch Fastener Torque: 8 ft.lbs. (11 Nm)
Compartment Door-To-Fasteners: 8 ft.lbs. (11 Nm)
Hinge Base-To-Top Deck Fasteners: 14 ft.lbs. (19 Nm)

HULL AND BODY

Shroud and Storage Assemblies

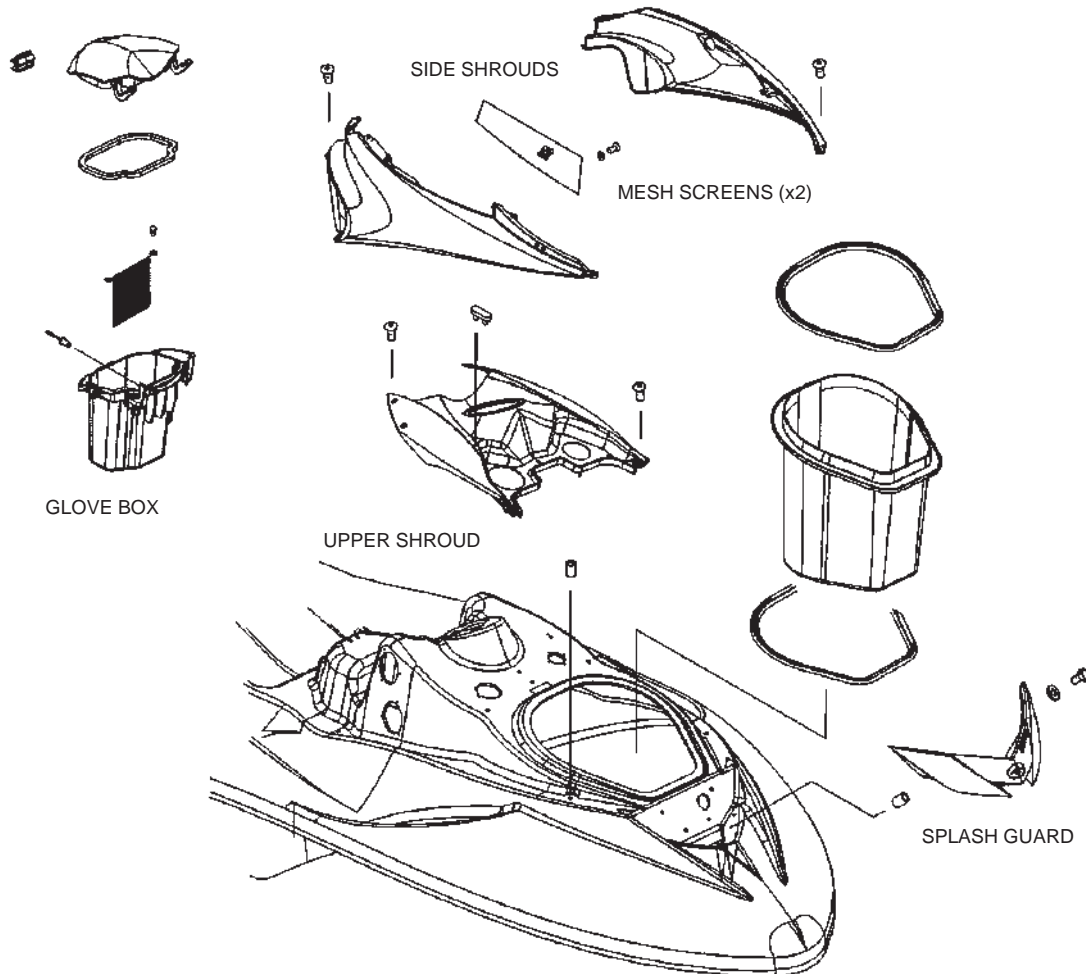

SHROUD AND STORAGE ASSEMBLY NOTES

Splash Guard Fastener Torque: 40 in.lbs. (4.5 Nm)
Side Shrouds - To - Upper Shroud Fasteners: 23 ft.lbs. (31 Nm)
Mesh Screen Fastener Torque: 10 in.lbs. (1 Nm)
Shroud Assembly - To - Deck Fastener Torque: 5 ft.lbs. (7 Nm)

HULL AND BODY

Seat Assembly

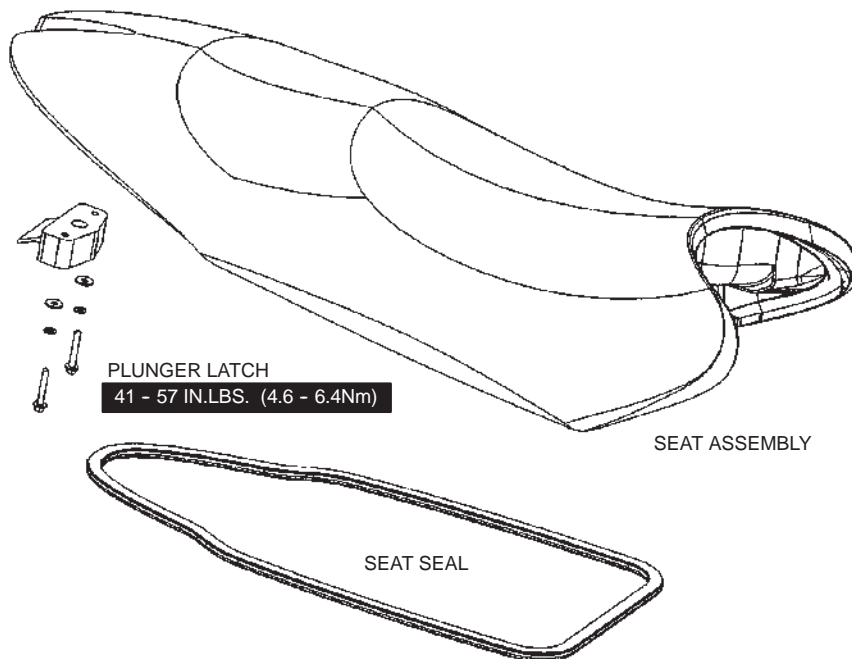

SEAT ASSEMBLY NOTES

Plunger Latch Fasteners 41 - 57 in.lbs. (4.6 - 6.4Nm)

Seat Post Nut Torque: 18 ft.lbs. (24Nm) Apply Loctite™ 262 to nut threads.

Seat post height is fixed.

HULL AND BODY

Steering Control Assembly

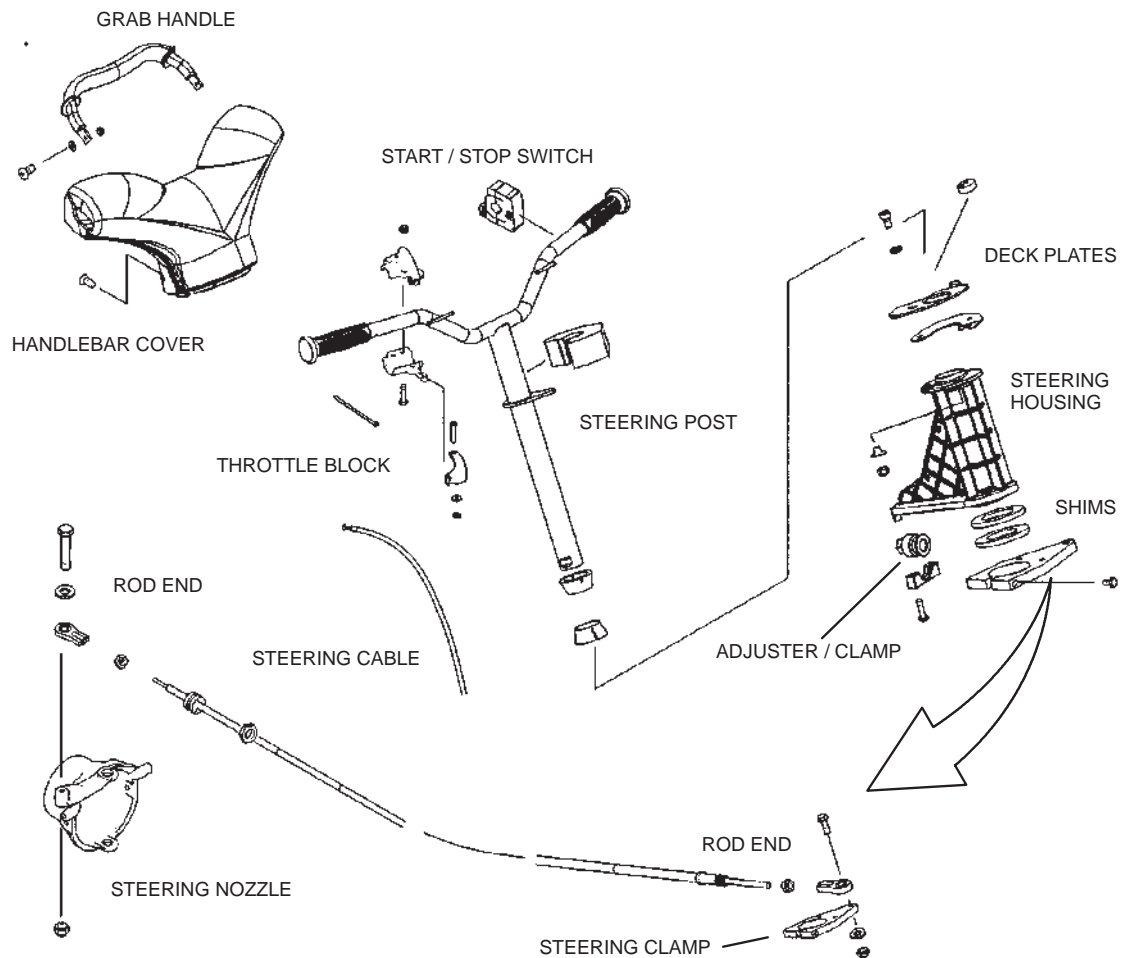

STEERING CONTROL ASSEMBLY NOTES

Handlebar Cover Fasteners: 20 in.lbs. (2 Nm)
Steering Housing-To-Top Deck: 14 ft.lbs. (19 Nm)
Steering Cable Adjuster Clamp: 8 ft.lbs. (11 Nm) Apply Loctite 242™.
Steering Arm Clamp: 8 ft.lbs. (11 Nm) Apply Loctite 242™.
Throttle Block: 20 in.lbs. (2 Nm)
Rod Ends: 8 ft.lbs. (11 Nm) Apply Loctite 242™.
Handlebar Grab Handle: 35 in.lbs. (4 Nm)
ESP Cam-To-Steering Clamp: 5 ft.lbs. (7 Nm) Apply Loctite 242™.

REFERENCE HANDLEBAR REMOVAL AND INSTALLATION PROCEDURES ON PAGE 7.14 FOR STEERING POST SHIM LOCATIONS AND INSTALLATION NOTES.

HULL AND BODY

ESP Switch Assembly

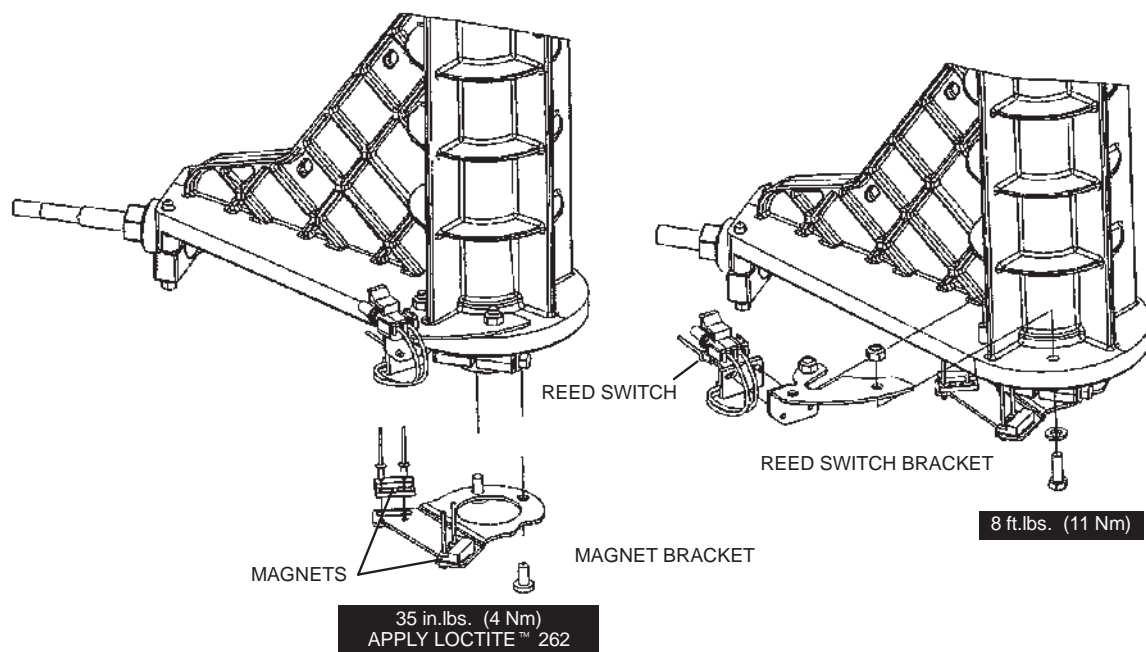

ASSEMBLY NOTES

Magnet Bracket Fastener Torque: 35 in.lbs. (4 Nm) Apply Loctite™ 262 to threads.
Reed Switch Bracket Nut Torque: 8 ft.lbs. (11 Nm)

HULL AND BODY

PPU Assembly

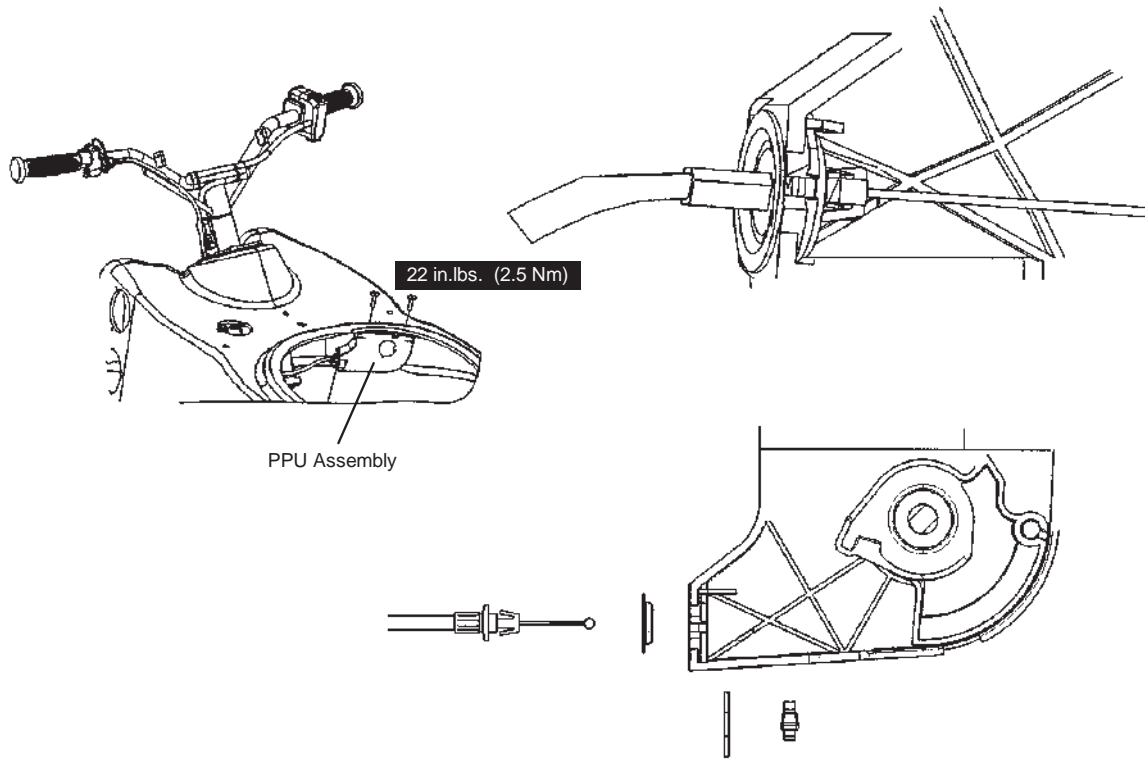

ASSEMBLY NOTES

PPU - To - Top Deck Fastener Torque: 22 in.lbs. (2.5 Nm)

HULL AND BODY

Reverse System Assembly

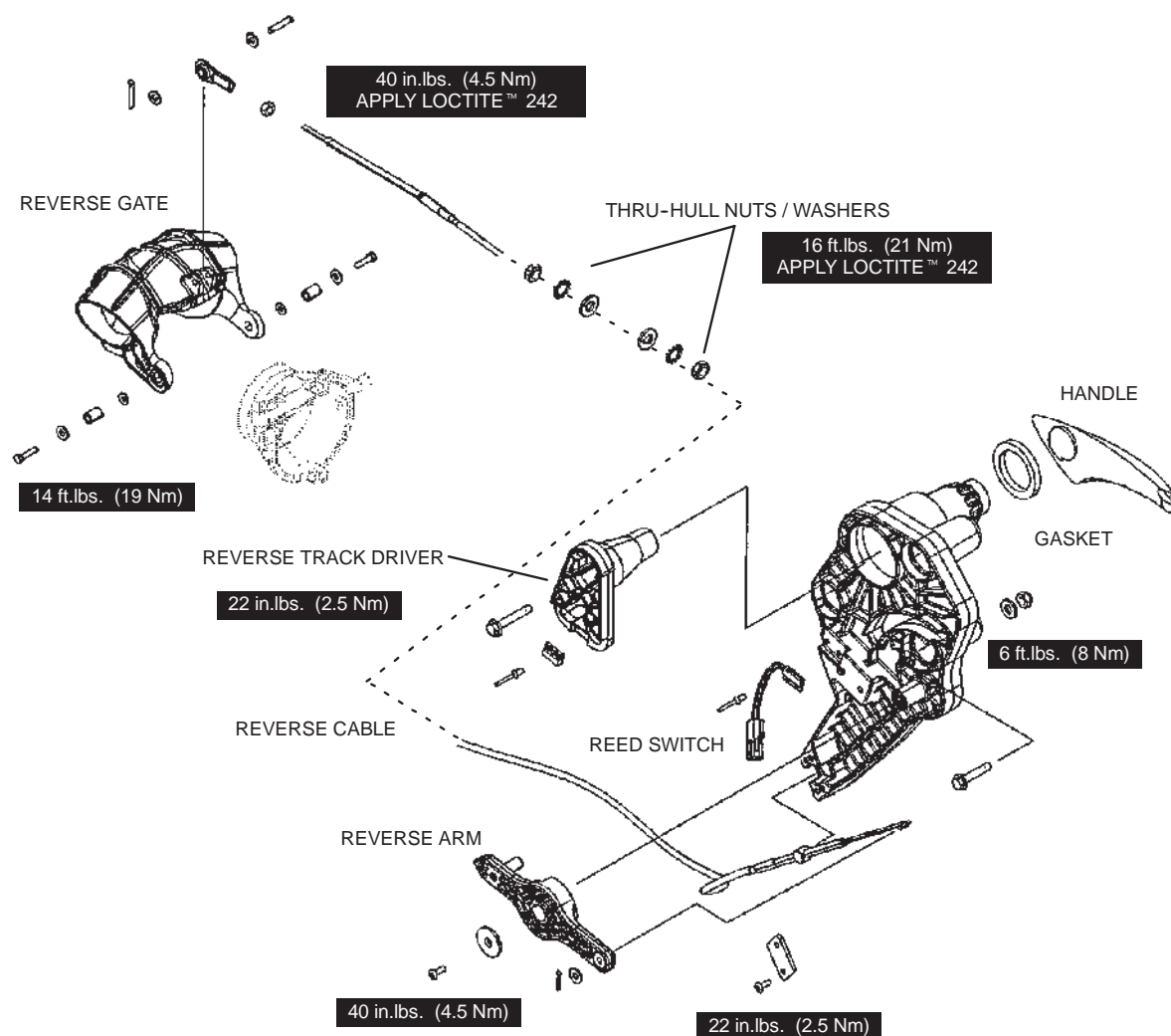

ASSEMBLY NOTES

- Reverse Cable Retainer Plate Fastener Torque: 22 in.lbs. (2.5 Nm)
- Reverse Arm Fastener Torque: 40 in.lbs. (4.5 Nm)
- Reverse Assembly - To - Top Deck Nut Torque: 6 ft.lbs. (8 Nm)
- Reverse Cable Thru-Hull Lock Nut Torque: 16 ft.lbs. (21 Nm) Apply Loctite™ 242 to threads.
- Reverse Cable Jam Nut Torque: 40 in.lbs. (4.5 Nm)
- Reverse Gate Pivot Fastener Torque: 14 ft.lbs. (19 Nm) Apply Loctite™ 242 to threads.

Apply Premium All Season Grease to exposed parts of reverse cable.
Apply Lithium-based grease to reverse assembly moving parts.

HULL AND BODY

Handlebar Cover / Steering Post Removal

Steering Post Removal

1. Remove handlebar cover fasteners. The grab handle fasteners are located under the cover. If grab handle replacement is required, remove the two fasteners as well.
2. Disconnect the throttle cable from the throttle flipper, and the left-hand control wiring harness.
3. Loosen and remove the steering arm clamp retaining bolt from the bottom of the steering post. Remove the clamp, shim(s) and tapered bushing from the post.
4. Carefully pull the steering post assembly up and out of the steering housing.

NOTE: The steering cable rod-end can remain connected to the steering clamp. If the rod-end is removed, discard the Nylok nut.

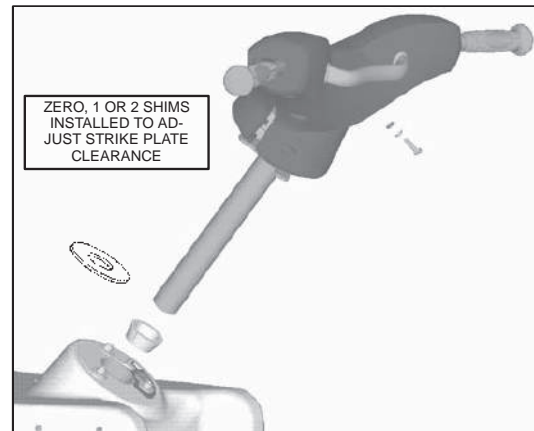

Steering Post Assembly

1. Apply lithium-based grease to the outside taper of the upper tapered bushing and steering post.
2. Insert the post assembly into the steering housing.
3. Push down on the handlebars. Verify the strike plate just clears the stop bolt washer and cannot be turned past the stop bolt.
4. If strike plate hits washer, remove post and install shim between bushing and strike plate. Repeat step 3. If plate continues to hit washer, install second and final shim.
5. Apply lithium-based grease to the outside taper of the lower tapered bushing and install into steering housing.
6. The number of shims installed on the lower section of the post is determined by the number installed on top. The total number of shims used to install the entire steering post assembly equals two. (If two shims are installed on top, then zero shims are installed on the bottom, etc.)
7. Align slot on steering arm clamp with cutout in post. Push clamp up against shims while pushing down on the handlebars. Torque bolt to 8 ft.lbs. (11 Nm).
8. Verify handlebars move without resistance from left to right and that handlebars cannot be turned past the steering stop bolt.
9. If steering cable rod-end was removed, reinstall on top of clamp using a new nut. Torque nut to 8 ft.lbs. (11 Nm)
10. Reconnect wiring harness and throttle cable. Verify throttle cable freeplay is set to specifications outlined in chapter two.
11. Reinstall the handlebar grab handle and cover assembly.

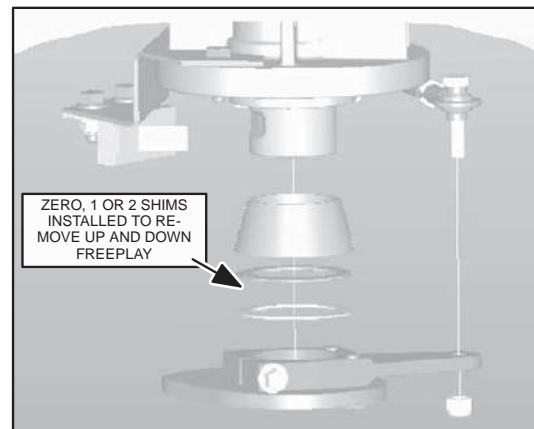
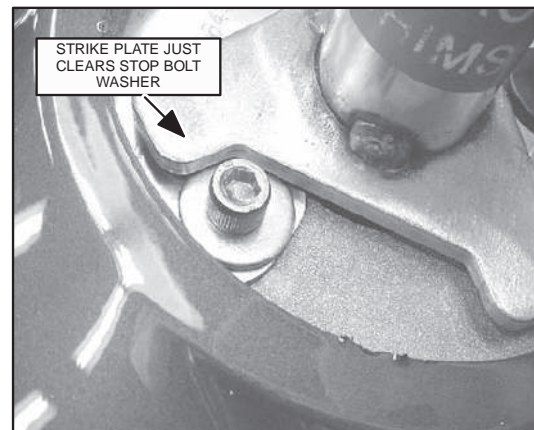

HULL AND BODY

Steering Cable Removal / Installation

WARNING: Failure to properly install the steering cable can result in loss of vehicle control possibly causing severe injury or death.

1. Remove seat and front storage compartment.
2. Visually inspect the engine compartment. Note the current routing of the steering cable.
3. Loosen and remove the steering linkage from the steering nozzle. Discard the nylock nut.

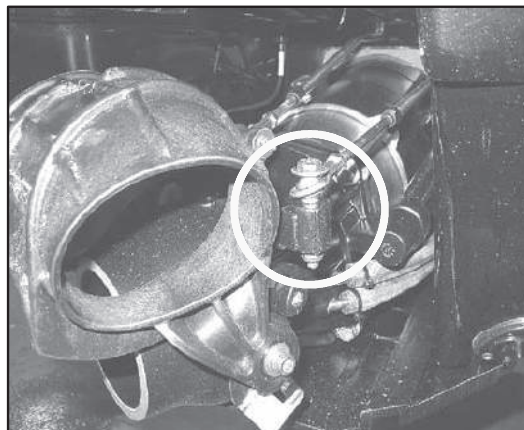

4. Prior to removing the thru-hull nut, loosen, *but do not remove*, the lockplate nut. With the lockplate loose, use an adjustable-locking wrench to remove the thru-hull nut.

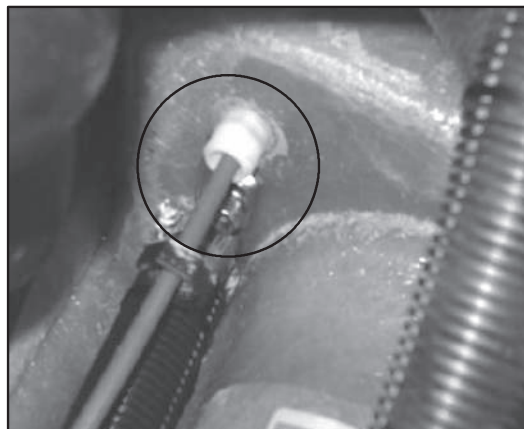

5. Locate and disconnect the rod end that is bolted to the steering arm underneath the shroud and top deck. Discard the nylock nut.
6. Remove the jam nut and rod end from the steering cable. Remove the adjuster clamp from the steering housing. Remove adjuster nut from steering cable.
7. Working from the front of the watercraft to the back, push the steering cable through the rear thru-hull opening.

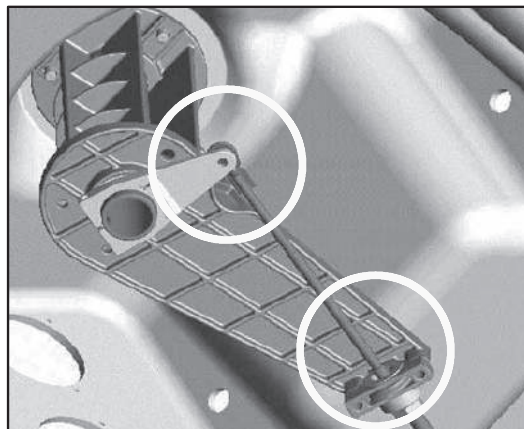

HULL AND BODY

Steering Cable Installation

1. Insert the new cable through the rear thru-hull fitting from the back of the watercraft following the routing you noted in removal.

NOTE: Verify that there are no sharp bends or kinks in the cable before proceeding to the next step.

2. Slide the black thru-hull nut onto the steering cable from inside the engine compartment.
3. Apply marine-grade silicone to the thru-hull fitting threads.
4. Tighten the thru-hull fitting nut to 52 in.lbs. (6 Nm)
5. Turn locking plate flat towards thru-hull nut face. Tighten nut to 28 ft.lbs. (39 Nm)
6. Lightly grease the upper steering linkage.
7. Thread steering cable into adjusting nut. Loosely fit adjusting nut bracket onto steering column base.
8. Install steering cable rod-end on top side of steering arm clamp. Using a new Nylok nut, torque nut to 8 ft.lbs (11 Nm).
9. Follow steering cable alignment procedures on page 6.13.
10. When finished, verify adjusting nut clamp fasteners are torqued to 8 ft.lbs. (11 Nm)

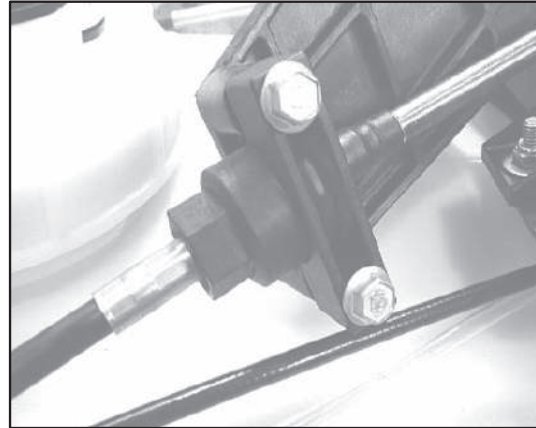

HULL AND BODY

Steering Cable Adjustment

1. Open front compartment door. Loosen and remove adjuster block. Align handlebars with centerline of watercraft. (Straight)
2. Place a straight edge across horizontal center line of steering nozzle or trim nozzle.
3. Measure distance from straight edge to hull on left and right side. Be sure to measure at right angles to the straight edge and at equal distances from the nozzle. The distance at (X) should be equal when handlebars are straight.
4. Adjustments can be made at the adjuster block. Turn block clockwise or counterclockwise until (X) measurements equal.
5. Tighten adjuster block screws to specification.

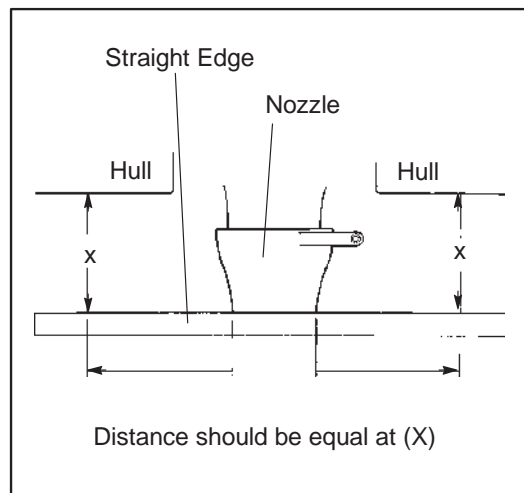

Reverse Cable Adjustment

Under normal operation, the reverse cable should not require adjustment. If the reverse linkage does not function properly, inspect the cable for damage. Inspect all linkage, fasteners, brackets, and pivots for wear or damage. When a new cable is installed the cable must be adjusted.

1. Place reverse shift lever in reverse position.
2. Loosen cable adjuster nuts.
3. Verify that the gate is in its full down position and locked.
4. Check gate locking by pulling up on gate when in down position.
5. Move shift lever to forward position. Reverse gate must be well above the water stream.
6. Tighten adjuster nuts securely.
7. Seal the cable threads and adjuster nuts with marine grade silicone sealant (PN 8560054) and tighten securely. Allow sealant to cure fully before operating craft.

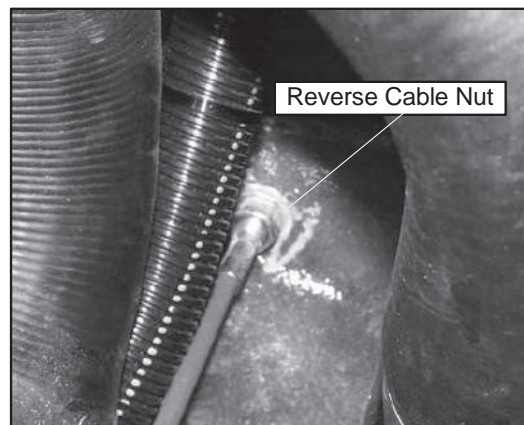

HULL AND BODY

Top Deck / Hull Repair

The hull and top deck are manufactured using Fiberglass Reinforced Compound (FRC).

Repair kits are available through Polaris Industries. Detailed instructions regarding material preparation, setup and cure times are included with each kit. However, sound knowledge of FRC repair is required when working with these kits. Polaris recommends that a dedicated marine-fiberglass repair facility inspect or be consulted with prior to attempting any repairs.

Footpad Removal

1. Peel off the footwell pad that is to be replaced. Use a heat gun to soften the adhesive.

WARNING: Use the heat gun on its lowest heat setting. Do not heat the footwell pad or hull for more than a second. Waiving the heat gun back and forth once is sufficient to soften the adhesive. Prolonged heating will permanently damage the hull.

2. With the footwell pad removed, apply Goo Gone™ and remove all old adhesive from the hull. If scraping is required, only use a soft plastic material.
3. Remove Goo Gone™ with mild detergent soap. Wipe surface with acetone. Allow Acetone to completely dry.

Footpad Application

4. Peel a small portion of backing material away from the new footwell pad, and immediately apply to deck.
5. Work the pad with your fingertips until the entire pad is pressed onto the deck surface. Constant pressure activates the adhesive and works out any air bubbles out from under the pad.
6. Allow for 24 hours for adhesive to cure.

NOTE: Do not allow the pad temperature to exceed 80°F, or below 60°F for at least 24 hours. Always cover the watercraft when exposed to direct sunlight for long periods time.

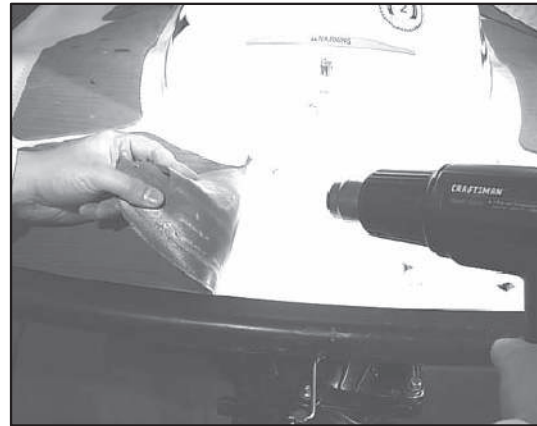



POLARIS[®] *WATERCRAFT*

MSX 110 / 150 Service Manual

Electrical Systems

Chassis Electrical and Sensor Specifications	8.1
Battery and Charging System Specifications	8.1
NGI Gauge	8.2 - 8.3
NGI Gauge Wiring Illustration / MIL Indicators	8.4
Battery Testing / Maintenance	8.5 - 8.7
Alternator Assembly	8.8
Charging System Illustration	8.9
Start / Stop Electrical System Illustration	8.10
System Interface Box Overview	8.11 - 8.12
Starter Motor Illustration	8.13
Starter Motor Disassembly / Assembly / Troubleshooting	8.14 - 8.18

ELECTRICAL SYSTEMS

Chassis Electrical and Sensor Specifications

Component	Specification
FUSES NGI Gauge Fuel Pump Ignition / ECU Regulator / Rectifier Main Relay (Lambda Sensor / Fuel Pump / Ignition Coils / Fuel Injectors) Main Relay (Switched ECU Battery Supply Input)	2AMP 10AMP 15AMP 30AMP 2 X 15AMP Fuses 15AMP
Oil Pressure Switch Continuity Pressure	11 - 16 psi (.8 - 1.1 BAR)
Fuel Level Sender	33Ω (FULL) / 240Ω (EMPTY)
Starter Solenoid	5 - 6Ω

Battery and Charging System Specifications

Component	Specification
Battery Type	YB16CL-B
Voltage	12 Volts
Nominal Capacity @ 10 Hour Rate	19 AH
Filling Specific Gravity	1.265 ± .010 @ 77°F (25°C)
Fully Charged Specific Gravity	1.280 ± .010 @ 77°F (25°C)
CCA @ 0°F (-18°C)	240 AMPS
Recommended Charging Current	1.9 AMPS
Electrolyte Volume	41.0 oz.
Reserve Capacity	25 minutes
Charging System	3 Phase Alternator w/external voltage regulator.
Alternator Output Voltage (No Load) 1200 RPM 2500 RPM 5000 RPM	21.3 Vac 43.5 Vac 87.0 Vac
Alternator Coil Resistance @ 87°F (37°C) @ 248°F (120°C)	285 mΩ 385 mΩ
Alternator Output 1200 RPM 2500 RPM 5000 RPM	10 AMPS 20 AMPS 25 AMPS
Nominal Voltage	12 Vdc
Nominal Current	25 - 30 AMPS
Maximum Electrical Power	350 Watts @ 5000 RPM
Regulated Voltage	14.3 - 14.6 Vdc Minimum Voltage w/charged battery: 14.1 Vdc
Starter Motor Draw No Load Load Stalled	45A / 10.9 Vdc 120A / 9 Vdc 390A / 2.25 Vdc
Starter Motor Brush Length Service Limit	5/16" (8mm)

ELECTRICAL SYSTEMS

NGI Gauge (Next Generation Instrument)



Primary Functions

- Speedometer
- Tachometer
- Engine Hourmeter
- Clock
- Trip Odometer
- Fuel Level
- Turbo Boost Level
- Low Oil / Pressure, Fuel, and Low Battery Voltage Warnings
- High Engine Temperature Warning
- Check Engine Display

Function Overview

Speedometer

The large numeric speedometer displays vehicle speed. The gauge receives signals via a paddle wheel located on the ride plate. The gauge interprets these signals and computes actual vehicle speed. Maximum displayed speed is 65 MPH (99Km/H). Vehicle speed over these maximums will not be displayed. Additionally, vehicle speed at, or below 3 MPH (5 Km/H), will be displayed as 0 MPH (0 Km/H).

Tachometer

Engine RPM is displayed on the gauge. The gauge has the ability to display between 0 and 9990 RPM. The gauge receives the tachometer signal from the ECU. Display tolerance is ± 100 RPM.

Fuel Level

Current fuel level is displayed via a 8 bar LCD graphic. Levels are displayed in 1/8th increments. When the fuel level displayed is 1/8 or less, a LOW FUEL symbol and red LED warning light will begin blinking warning the operator to re-fill the fuel tank.

Engine Hourmeter

Engine hours are numerically displayed on the gauge. Maximum engine hours retained and displayed by the gauge is 999.9. Hours obtained after 999.9 will not reset the gauge to zero. The gauge begins to record engine hours whenever the engine RPM is 500 RPM or higher. Memory retention is approximately 10 years.

NOTE: Fuel and Turbo LCD Bars shown at maximums in photo.

ELECTRICAL SYSTEMS

NGI Gauge - Continued

Clock

The gauge display time in the main display mode without AM / PM displayed. (1:00 to 12:59)

Highest Speed / Engine RPM Record

Both the highest speed and highest engine RPM are recorded separately. Both are displayed in the speed / tachometer display mode.

Trip Odometer

The gauge will display accumulated miles or kilometers traveled. The gauge will only begin recording distance traveled when engine RPM is at or above 500 RPM.

Turbo Boost

Turbo boost pressure levels are displayed via a 7 bar LCD graphic.

NOTE: Displayed turbo boost is generated by the RPM signal, not manifold pressure. Engine cannot obtain maximum RPM without full boost pressure.

Instrument Operation

DISPLAY MODE:

There are 3 different display modes that the gauge uses to display information to the operator. The 3 modes are: MAIN MODE, SPEED / TACHOMETER MODE, AND NAVIGATION MODE. Press and release the MODE button on the left handlebar control to advance through the 3 display modes. High speed record will display for 3 seconds when entering the speed / tachometer display mode, then revert to real time speed / tachometer. Pressing the MODE button a second time will advance to the trip odometer, while a third will return to the clock display.

CLOCK SET:

In the main mode, press and hold the RESET button until the hour digits flash. (Approximately 6 seconds.) Press RESET button to advance hour digits. Press the MODE button to stop hour digits flash and begin minute digits flash. Press RESET button to advance 1 minute. Press MODE button to set clock and exit clock set mode.

TRIP ODOMETER RESET

To reset the trip odometer, press and hold the RESET button until the trip odometer is reset to 000.0 miles / km.

HIGH SPEED RECORD DISPLAY

Press the RESET button to display the high speed record when in the speed / tachometer display mode. To reset the high speed record, press and hold RESET button again for about 2 seconds or until the display is reset.

CHANGING UNITS OF MEASURE

To toggle between standard and metric units of measure, press and hold the MODE button for 10 seconds.

Displayed Warnings

The gauge will alert the operator for the following conditions:

- LOW FUEL (Fuel level reaches 1/8 level.)
- LOW OIL PRESSURE
- LOW BATTERY VOLTAGE (Battery voltage is at or below 10.9 vDC.)
- HIGH TEMPERATURE (Temperature is monitored by ECU.)
- CHECK ENGINE (Check engine warning is triggered by ECU.)

Regardless of warning, all warnings will have their respective ISO symbol displayed on the screen as well as a blinking red LED warning lamp.

NOTE: Warning display icons have a 10 ±1 second OFF delay time interval.

ELECTRICAL SYSTEMS

NGI Gauge (Next Generation Instrument) - ENGINE MIL INDICATORS

NGI GAUGE CONNECTOR

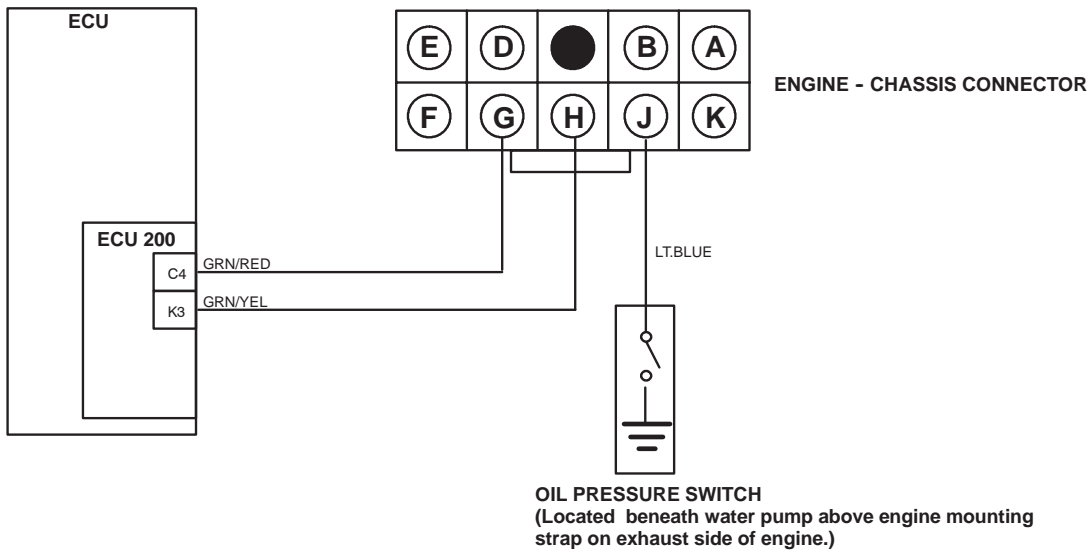
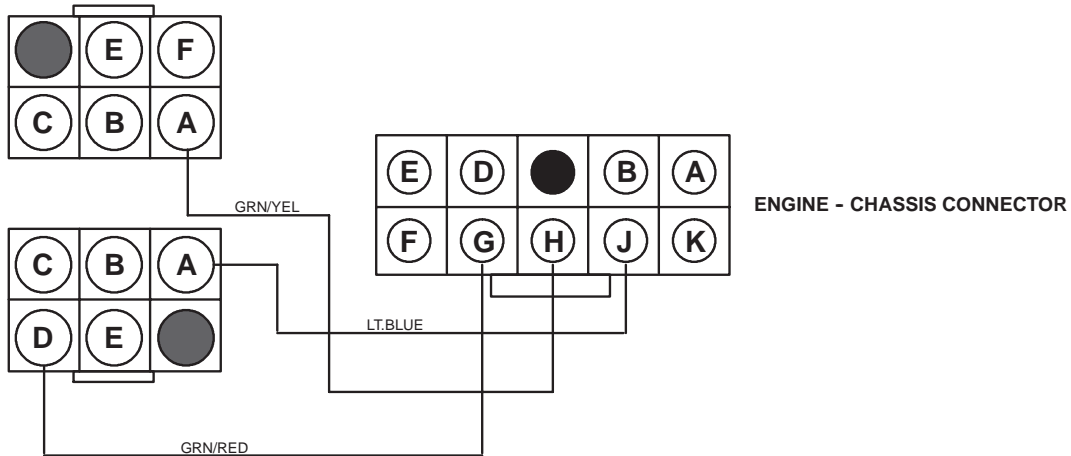

NGI Gauge (Next Generation Instrument) – ENGINE MIL INDICATORS Legend

LT. BLUE	OIL PRESSURE SWITCH SIGNAL. (LOSS OF PRESSURE CLOSES SWITCH. NO COMMUNICATION WITH ECU)
GRN/RED	CHECK ENGINE MIL WARNING LAMP SIGNAL
GRN/YEL	ENGINE OVERHEAT / EXHAUST MANIFOLD OVERHEAT SWITCH MIL WARNING LAMP

Rev. A 1/12/2004

ELECTRICAL SYSTEMS

Battery Testing

 **WARNING:** Whenever installing batteries, care should be taken to avoid the possibility of explosion, resulting in serious burns. Always connect the positive (red) cable first and the negative (black) cable last. When working with batteries, always wear safety glasses or a face shield and protective gloves. Battery electrolyte contains sulfuric acid and is poisonous! Serious burns can result from contact with the skin, eyes or clothing. **ANTIDOTE:** External - Flush with water. Internal - Drink large quantities of water or milk. Follow with milk of magnesia, beaten egg, or vegetable oil. Call physician immediately. Eyes - Flush with water for 15 minutes and get prompt medical attention.

Preparing A New Battery For Service

NOTE: Do not service the battery unless it will be put into regular service within 30 days.

To assure maximum service life and performance from a battery, it must have proper initial servicing. To service a new battery, the following steps must be taken:

- Remove vent plug from vent fitting.
- Fill battery with electrolyte to upper level marks on case.
- Set battery aside and allow it to cool and stabilize for 1/2 hour.
- Add electrolyte to bring level back to upper level mark on case. **NOTE:** This is the last time that electrolyte should be added. If the level becomes low after this point, add only distilled water.
- Charge battery at 1/3 of its amp/hr rating for up to 2 hrs. **NOTE:** This charge rate is to be used only on new batteries during the first-time charge. After this charge, they should be charged at the normal charge rate of 1/10 of amp/hr.
- Check specific gravity of each cell with a hydrometer to assure each has a reading of 1.270 or higher.

Battery Testing

There are three tests which can easily be made to determine a battery's condition. Whenever the complaint is related to either the starting or charging systems, the battery should be checked first.

OCV - Open Circuit Voltage Test

Battery voltage should be checked with a digital multimeter. Readings of 12.4 DCV or less require further battery testing and charging.

NOTE: Lead-acid batteries should be kept at or as near full charge as possible. If the battery is stored or used in a partially charged condition, hard crystal sulfation will form on the plates, reducing their efficiency and possibly ruining the battery.

ELECTRICAL SYSTEMS

Specific Gravity Test

A tool such as the battery hydrometer can be used to measure electrolyte strength or specific gravity. As the battery goes through the charge-discharge cycle, the electrolyte goes from a heavy (more acidic) state at full charge to a light (more water) state when discharged. The hydrometer can measure state of charge and differences between cells in a multi-cell battery. Readings of 1.270 or greater should be observed in a fully charged battery. Differences of more than .025 between the lowest and highest cell readings indicate a need to replace the battery.

Open Circuit Voltage

STATE OF CHARGE	CONVENTIONAL LEAD-ACID	YUMICRON TYPE
100% Charged	12.60V	12.70V
75% Charged	12.40V	12.50V
50% Charged	12.10V	12.20V
25% Charged	11.90V	12.0V
0% Charged	less than 11.80V	less than 11.9V



Detail A

1.10
1.15
1.20
1.25
1.30

Specific Gravity

STATE OF CHARGE*	CONVENTIONAL LEAD-ACID	YUMICRON TYPE
100% Charged	1.270	1.275
75% Charged	1.210	1.225
50% Charged	1.160	1.175
25% Charged	1.120	1.135
0% Charged	less than 1.100	less than 1.115

* At 80°F

NOTE: Subtract .01 from the specific gravity reading at 40° F.

Battery Hydrometer

PN 2870836

Load Test

A battery may indicate a full charge condition in the OCV test and the specific gravity test, but still not have the storage capacity necessary to properly function in the electrical system. For this reason a battery capacity or load test should be conducted whenever poor battery performance is encountered.

NOTE: This test cannot be performed with an engine or starting system that is not working properly.

1. Attach a multimeter to the battery. The reading should be 12.4 DCV or greater.
2. Engage electric starter and view registered battery voltage while cranking engine. Continue the test for 15 seconds. During this cranking period, the observed voltage should not drop below 9.5 volts. If the beginning voltage is 12.4 or higher and the cranking voltage drops below 9.5 volts during the test, replace the battery.

ELECTRICAL SYSTEMS

Refilling a Low Battery

The normal charge/discharge cycle of a battery causes the cells to give off hydrogen and oxygen. These gases are the ingredients of water. Because of the loss of these gases and the lowering of the electrolyte level, it will be necessary to add pure, clean distilled water to bring the fluid to the proper level. After filling, charge the battery to raise the specific gravity to the fully charged (1.270 or greater) position.

Off-season Storage

To prevent battery damage during extended periods of non-use, the following basic battery maintenance items must be performed:

- Remove battery from machine and wash case and battery tray with a mild solution of baking soda and water. Rinse with lots of fresh water after cleaning. **NOTE:** Do not get any of the baking soda into the battery or the acid will be neutralized.
- Using a wire brush or knife, remove any corrosion from cables and terminals.
- Make sure electrolyte is at proper level. Add distilled water if necessary.
- Charge at a rate no greater than 1/10 of the battery's amp/hr capacity until the electrolyte's specific gravity reaches 1.270 or greater.
- Store battery either in machine with cables disconnected, or store in a cool dry place. **NOTE:** Stored batteries lose their charge at the rate of 1% per day. They should be recharged to a full charge every 60 to 90 days during a non-use period. If stored during the winter months, the electrolyte will freeze at a higher temperature as the battery discharges. The chart below indicates freezing points by specific gravity.

ELECTROLYTE FREEZING POINTS	
Specific Gravity of Electrolyte	Freezing Point
1.265	-75°F
1.225	-35°F
1.200	-17°F
1.150	+5° F
1.100	+18°F
1.050	+27°F

Charging Procedure

Charge the battery with a charger no larger than 1/10 of the battery's amp/hr rating for as many hours as needed to raise the specific gravity to 1.270 or greater.

WARNING

The gases given off by a battery are explosive. Any spark or open flame near a battery can cause an explosion which will spray battery acid on anyone close to it. Battery acid will cause burns to skin. In case of contact with battery acid, wash the affected area with large quantities of cool water and seek immediate medical attention.

ELECTRICAL SYSTEMS

Alternator Assembly

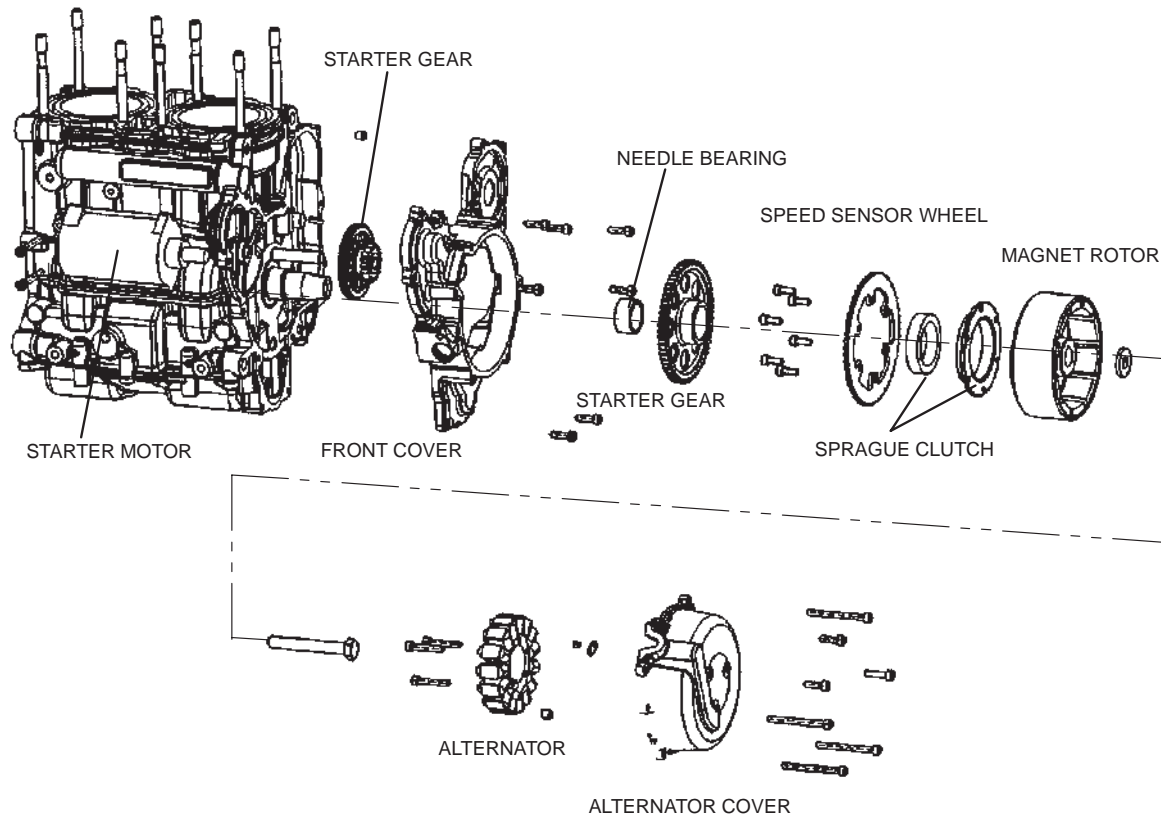

ASSEMBLY NOTES

Starter Motor Fastener Torque: 7ft.lbs. (10 Nm) Apply Nyogel to fasteners.

Front Gear Cover Fastener Torque: 7 ft.lbs. (10 Nm)

Speed Sensor Wheel / Sprague Clutch Fastener Torque: 7 ft.lbs. (10 Nm) Apply Loctite™ 272 to threads.

Magnet Rotor Bolt Torque: 73 ft.lbs. (100 Nm) Apply engine oil to bolt threads.

Alternator Fastener Torque: 7 ft.lbs. (10 Nm)

Alternator Cover Fastener Torque: 7 ft.lbs. (10 Nm)

ELECTRICAL SYSTEMS

Charging System

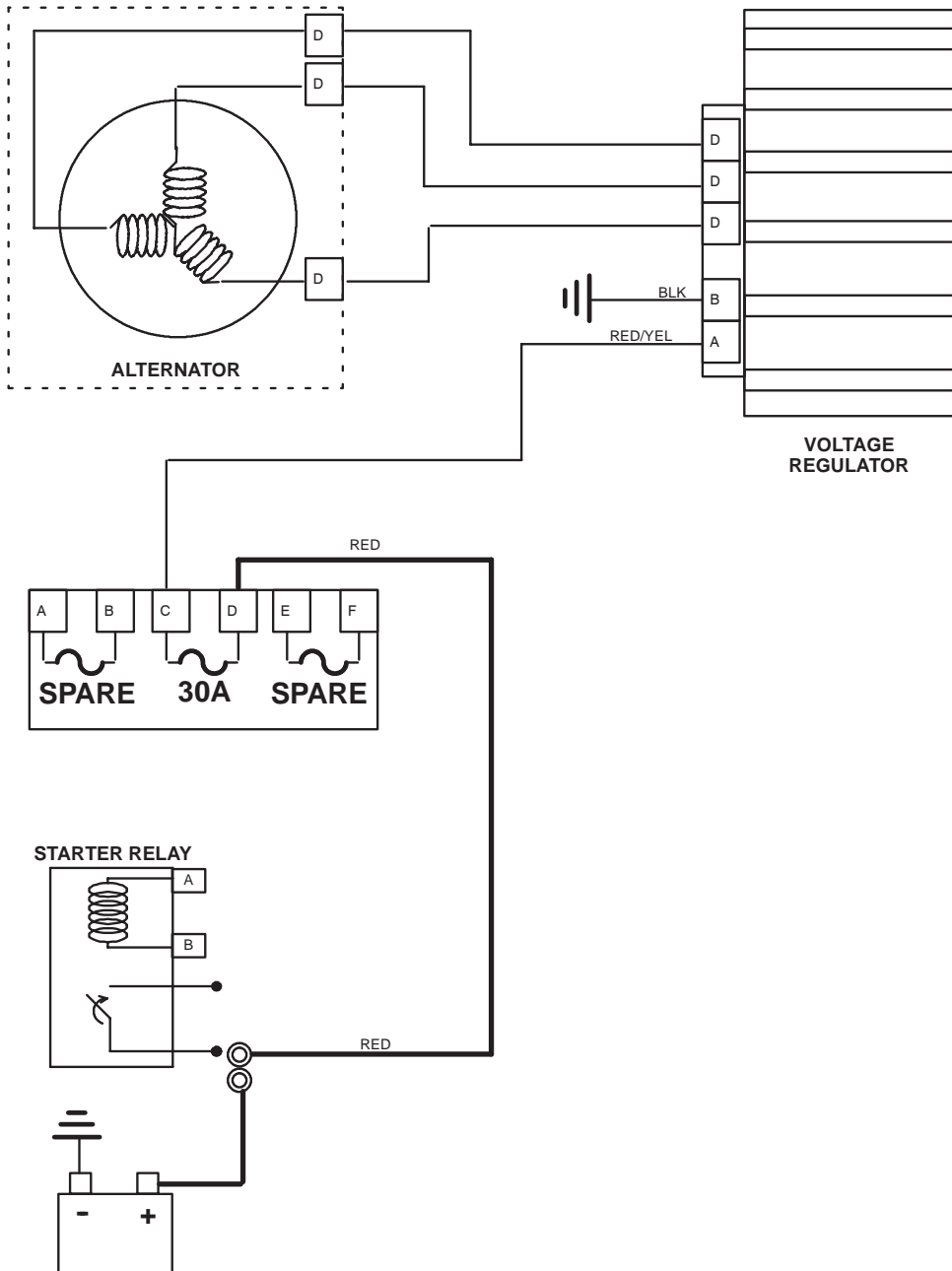

CHARGING SYSTEM – LEGEND

RED	12V BATTERY VOLTAGE
BLACK	CHASSIS GROUND
RED/PUR	FUSE PROTECTED / SWITCHED BATTERY VOLTAGE
YEL/RED	STARTER RELAY SIGNAL
PURPLE	SWITCHED ECU VOLTAGE

ELECTRICAL SYSTEMS

Start / Stop Electrical System

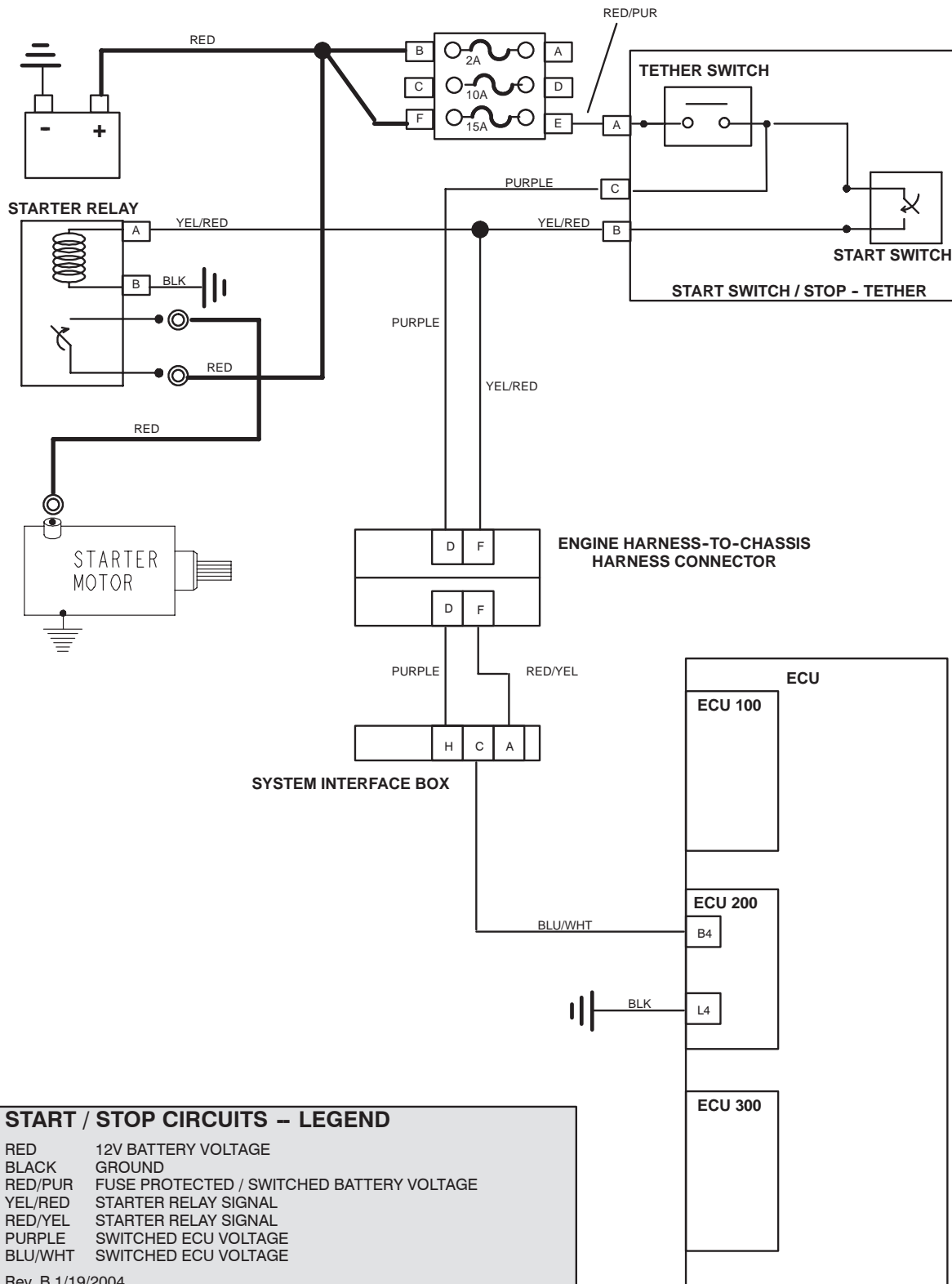

ELECTRICAL SYSTEMS

System Interface Box (SIFB)

The primary function of the SIFB is to power-down the ignition system in the event that the lanyard is left inserted in the stop switch for more than two minutes. Without the SIFB, the ignition system would remain powered-up by the battery, and the battery would completely discharge.

A secondary function of the SIFB is to convert the reverse switch signal so the ECU can interpret the signal when the reverse switch is closed, thereby limiting engine RPM.

How It works

The SIFB will disconnect the ECU ignition circuit and go into the “sleep” mode in the event that the lanyard is left installed in the stop switch for more than two minutes. This also holds true whenever the operator pushes the stop button momentarily while the engine is running.

In the event that the operator removes the lanyard from the stop switch while the engine is running, the SIFB does nothing.

To power-up the ECU after the SIFB has entered the “sleep” mode, the operator must re-insert (if removed) the lanyard into the stop switch, and press the start button.

NOTE: The SIFB remains in the mode in which it was put into by the operator’s last action. For example, the SIFB will allow the ECU to power-up immediately when the lanyard is installed if the operator’s last action was removing the lanyard to kill the engine.

Conversely, if the operator’s last action was leaving the lanyard in the stop switch for more than two minutes or stopping the engine by pushing the stop button, the ECU will not power-up until the SIFB “sees” a start signal generated by the operator pushing the start button.

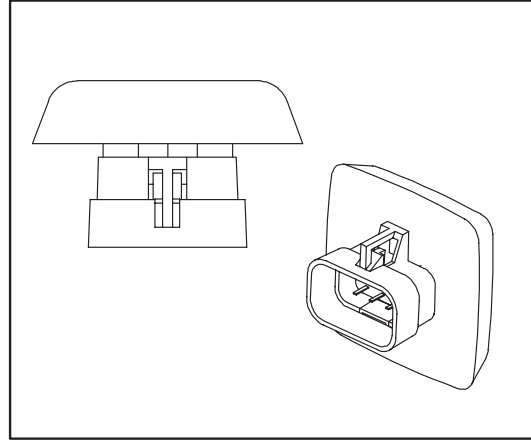

SIFB Diagnostics Mode

There will be situations where a user will want to defeat the sleep mode function of the SIFB. One such situation is when a technician is connected to the ECU with the Digital Wrench™ diagnostic software program.

To enter the SIFB diagnostic mode, follow these steps:

1. Insert the lanyard into the stop switch, and start the engine. Stop the engine by removing the lanyard.
2. Wait for 15 seconds, then re-insert the lanyard. Quickly push the STOP button three times within the first three seconds, then tap the START button.

The SIFB is now in the diagnostics mode. Power will be supplied to the ECU for as long as the lanyard remains installed.

To exit the diagnostics mode, remove the safety lanyard from the STOP switch and wait for at least 15 seconds.

NOTE: To verify the ignition system is powered-up after inserting the lanyard into the stop switch, move the throttle flipper from full closed to full open while the engine is off. The throttle plate can always be heard moving with the flipper movement when the ignition system has power.

ELECTRICAL SYSTEMS

System Interface Box (SIFB)

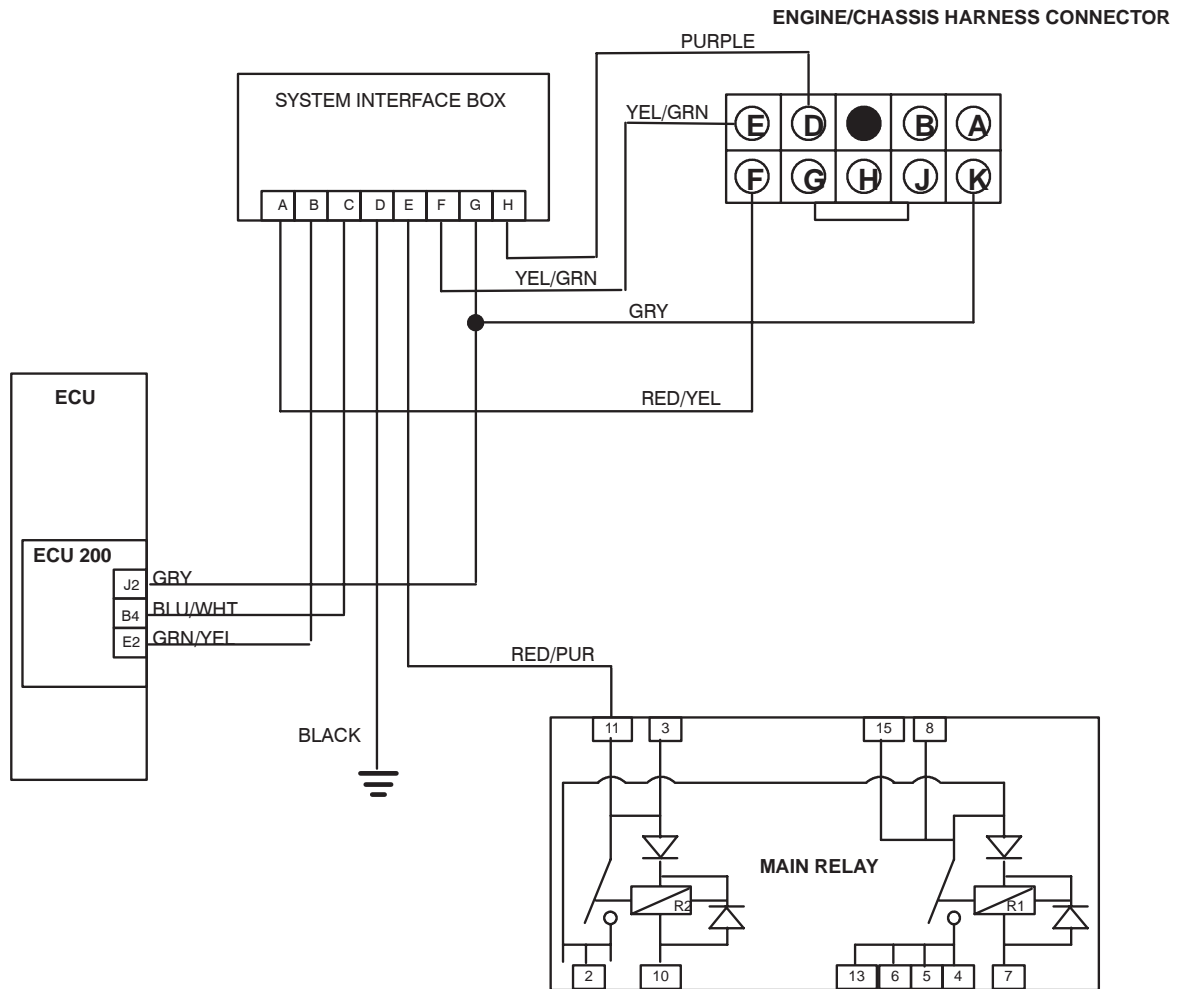

SYSTEM INTERFACE BOX (SIFB) – LEGEND

RED/PUR	12V BATTERY VOLTAGE
BLACK	GROUND
GRN/YEL	REVERSE SWITCH SIGNAL (FROM IFB)
BLU/WHT	IGNITION SWITCHED VOLTAGE (FROM IFB)
GRY	TACHOMETER SIGNAL
RED/YEL	IGNITION SWITCHED VOLTAGE (FROM START BUTTON)
YEL/GRN	REVERSE SWITCH SIGNAL (FROM REVERSE SWITCH)
PURPLE	IGNITION SWITCHED VOLTAGE (FROM TETHER SWITCH)

Rev. A 11/05/2003

ELECTRICAL SYSTEMS

Starter Motor

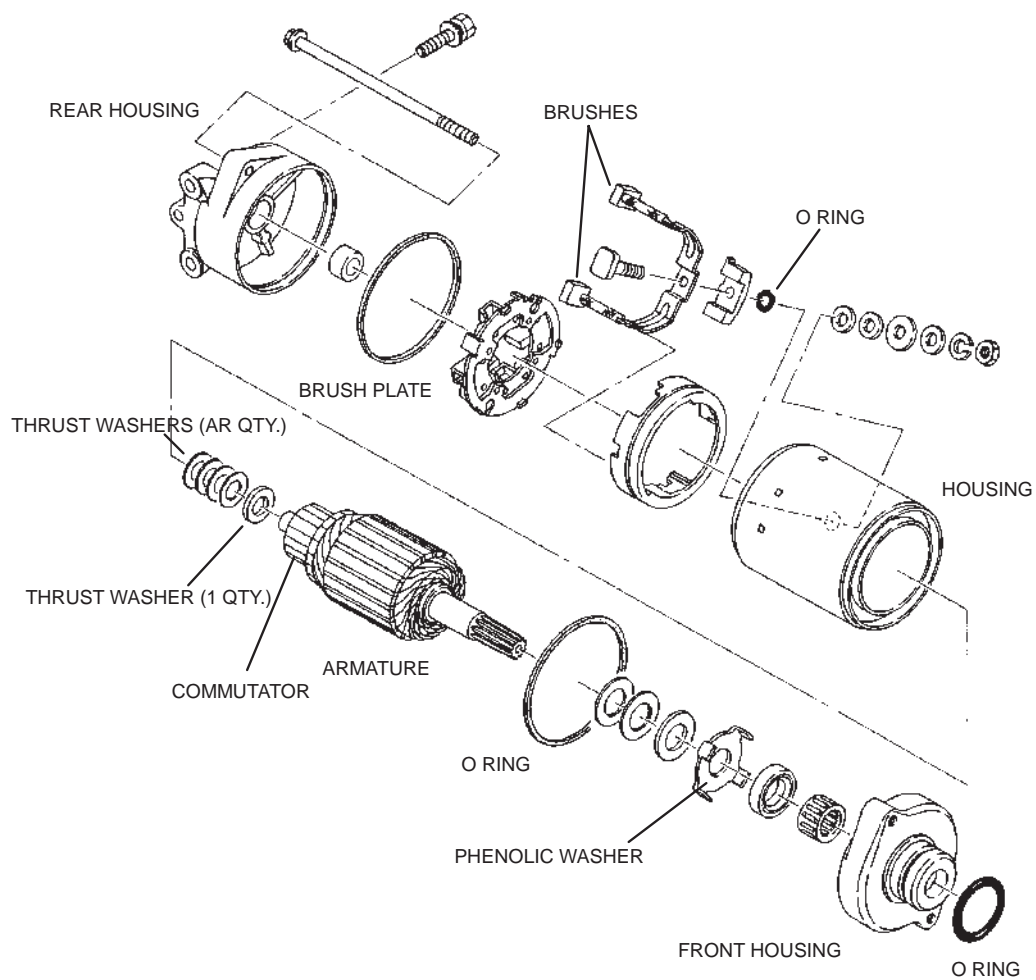

ASSEMBLY NOTES

Through Bolt Torque: 36 in.lbs. (4 Nm)

Brush Length Service Limit: 5/16" (8mm)

Verify all parts are clean thoroughly prior to assembly.

Always use new o rings during reassembly.

ELECTRICAL SYSTEMS

Starter Motor - Disassembly

1. Remove starter motor and disassemble. Mark end covers and housing for proper reassembly.
2. Remove housing through bolts.



3. Remove brush end bushing dust cover and armature thrust washers. Keep washers in order for reassembly.

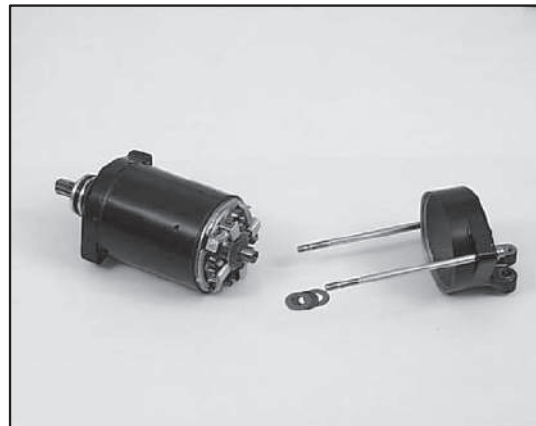

4. Remove drive end cover and armature. Remove thrust washer, phenolic washer, and shim washers. Keep washers in order for reassembly.



ELECTRICAL SYSTEMS

Starter Motor - Disassembly - Continued

5. Measure resistance between starter input terminal and insulated brushes. Reading should be .3 ohms or less. Remember to subtract meter lead resistance.

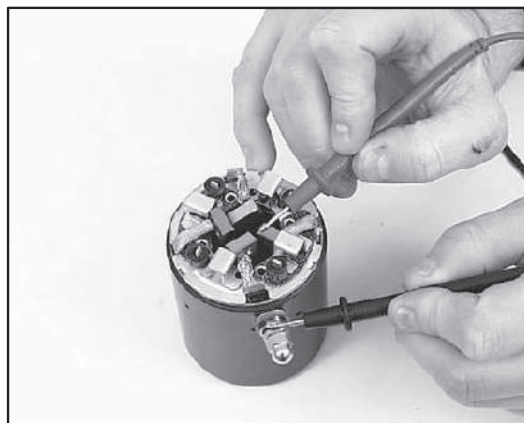

6. Measure resistance between insulated brush and starter housing. Reading should be infinite. (OL). Inspect insulation on brush wires for damage and repair or replace as necessary.



7. Slide positive brush springs to the side, pull brushes out of their guides and remove brush plate. Slide brush end frame off end of starter. **NOTE:** The electrical input post must stay with the field coil housing.

8. Measure resistance between ground brush and brush plate. Resistance should be .3 ohms or less.

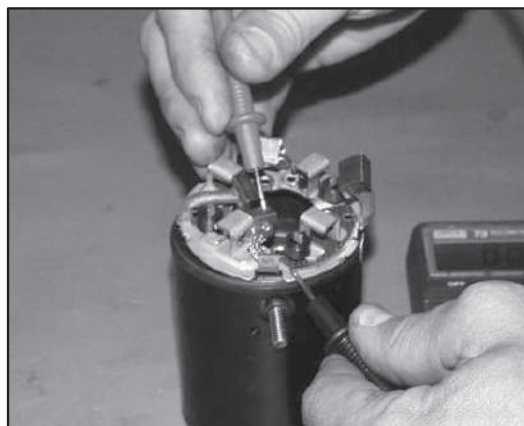

ELECTRICAL SYSTEMS

Starter Motor - Inspection

Brush Inspection

1. Measure length of each carbon brush. Replace brush assembly when worn to 5/16" (8 mm) or less. The brushes must slide freely in their holders.

Carbon Brush

Service Limit 5/16" (8mm)

Brush Replacement

1. Remove terminal nut with lock washer, flat washer, large phenolic washer, 2 small phenolic spacers, and sealing O-ring. Inspect O-ring and replace if damaged.
2. Slide positive brush springs to the side, pull brushes out of their guides and remove brush plate.

Cleaning

CAUTION:

Some cleaning solvents may damage the insulation in the starter. Care should be exercised when selecting an appropriate solvent. If the commutator needs cleaning use only an electrical contact cleaner.

Armature Testing

1. Using a digital multimeter, measure resistance between each of the segments of the commutator. The reading should indicate .3 ohms or less.
2. Measure resistance between commutator and armature shaft. Reading should be infinite (OL). Inspect surface of commutator wear or discoloration. Replace if excessively worn or damaged.
3. Place armature in a growler. With growler on, position a hacksaw blade lengthwise, 1/8" (.3 cm) above armature coil laminates. Rotate armature 360°. If the hacksaw blade is drawn toward the armature on any point, the armature is faulty and must be replaced.
4. Inspect permanent magnets in starter housing. Make sure they are not cracked or separated from housing.

CAUTION:

Use care when handling starter housing. Do not drop or strike the housing as magnet damage is possible. If magnets are damaged, starter must be replaced.

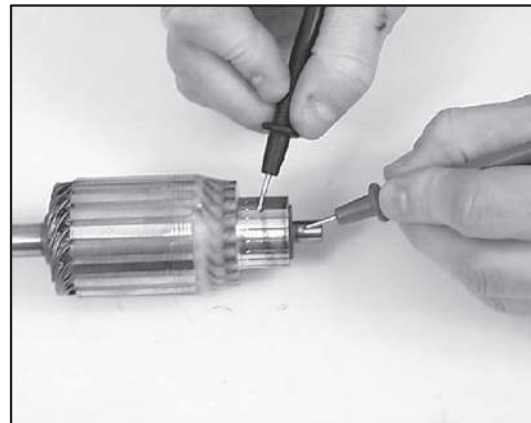
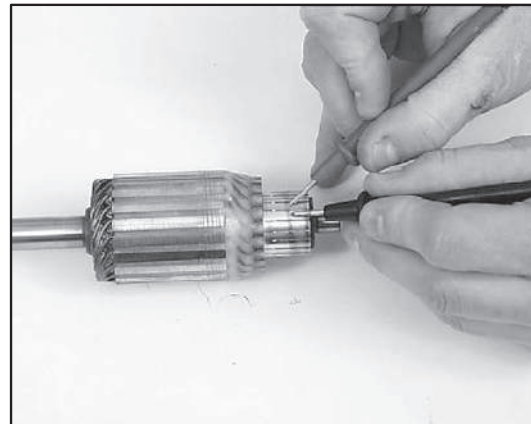
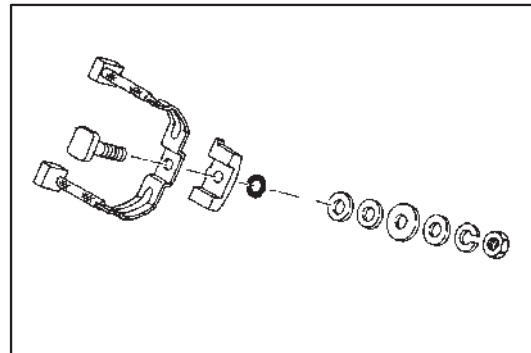

ELECTRICAL SYSTEMS

Starter Assembly

1. Install brush plate to field magnet housing aligning index tab.
2. Install O-ring, two small phenolic spacers, large phenolic washer, flat washer, lock washer, and terminal nut.
3. While holding brush springs away from brushes, push brushes back and hold in place.
4. Slide armature into field magnet housing. Release brushes.
5. Lightly grease drive end bushing and reinstall drive end frame on armature. Inspect seal for wear or damage. Replace drive end cap if necessary.
6. Be sure wire insulation is in place around positive brush wire and pushed completely into slot on phenolic plate.
7. Using a non-petroleum grease, lubricate brush end bushing and install shims.

Nyogel™ Grease PN 2871329

8. Align brush plate and install cover and screws.
9. Reinstall bolts and tighten evenly and securely.
10. Lightly grease pinion shaft and install pinion, spring stopper, and snap ring.

Starter Solenoid Bench Test

To measure the resistance of the pull-in coil, connect one meter lead to the Yellow/Red wire and the other to ground. The resistance should be 2.8-3.6 ohms. Refer to Electric Starter System Testing in this section to further test the solenoid.



ELECTRICAL SYSTEMS

Starter Motor - Troubleshooting

Condition: Starter fails to turn motor or motor turns slowly.

CAUTION:

Make sure that engine crankshaft is free to turn before proceeding.

<p>With the tester on Vdc, place the tester black lead on the battery negative (-) terminal and the tester red lead on the battery positive (+) terminal. Reading should be 12.4 V or greater. Is it?</p> <p style="text-align: center;">No→ Yes↓</p>	<p>Remove battery, test and/or service. Install a fully charged shop battery to continue the test. (Continue on with left column.)</p>
<p>Disconnect the red engagement coil wire from the starter solenoid. Connect the black tester wire to an appropriate ground and the red lead to the red harness wire at the solenoid. Push the start button. The meter should read battery voltage. Does it?</p> <p style="text-align: center;">No→ Yes↓</p>	<p>With the black tester lead on ground, check for voltage at the large relay in terminal, the circuit breaker in and out terminals, and across both sides of the start switch with the switch on start. Repair or replace any defective part(s).</p>
<p>Reconnect the solenoid. Connect the tester black lead to the battery positive terminal and the red tester lead to the solenoid end of the battery-to-solenoid cable. Push the start button. The reading must be less than .1 Vdc. Is it?</p> <p style="text-align: center;">No→ Yes↓</p>	<p>Clean the battery to solenoid cable ends or replace the cable.</p>
<p>Connect the black tester lead to the solenoid end of the battery-to-solenoid cable and the red tester lead to the solenoid end of the solenoid-to-starter cable. Push the start button. The reading must be less than .1 Vdc. Is it?</p> <p style="text-align: center;">No→ Yes↓</p>	<p>Replace the starter solenoid.</p>
<p>Connect the black tester lead to the solenoid end of the solenoid-to-starter cable and the red tester lead to the starter end of the same cable. Push the start button. The reading must be less than .1 Vdc. Is it?</p> <p style="text-align: center;">No→ Yes↓</p>	<p>Clean the solenoid-to-starter cable ends or replace the cable.</p>
<p>Connect the black tester lead to the starter frame. Connect the red tester lead to the battery negative terminal. Push the start button. Reading should be less than .1 Vdc. Is it?</p> <p style="text-align: center;">No→ Yes↓</p>	<p>Clean the ends of the engine-to-battery negative cable or replace the cable.</p>
<p>If all these tests indicate a good condition, yet the starter still fails to turn, or turns slowly, the starter must be removed for static testing and inspection.</p>	

MSX 110 / 150 Chassis Harness

2004 MSX 4-STROKE
 PAGE 1 OF 1
 06-NOV-2003

COLOR	TABLE
BLK	BLACK
BLU	BLUE
BRN	BROWN
GRN	GREEN
GRY	GRAY
OR	ORANGE
Y	YELLOW
W	WHITE

WIRES ARE REPRESENTED BY SOLID OR DASHED LINES TO SIMPLIFY TRACING IN DIAGRAM

WIRE COLOR	FROM CONNECTOR	TO CONNECTOR
BLACK 1	ENGINE GROUND	SPLICE
BLACK 2	PADDLE WHEEL	SPLICE
BLACK 3	STARTER SOLENOID	SPLICE
BLACK 4	NEG. SENDING UNIT	SPLICE
BLACK 5	NEG. WIRE HARNESS	SPLICE
BLACK 6	FUEL SENDING UNIT	SPLICE
BLUE 1	NEG. WIRE HARNESS	ENGINE HARNESS
GREEN/YELLOW	NEG. WIRE HARNESS	ENGINE HARNESS
GREEN/YELLOW	NEG. WIRE HARNESS	ENGINE HARNESS
ORANGE/BLACK	NEG. WIRE HARNESS	ENGINE HARNESS
PINK	FUEL SENDING UNIT	TO AMP FUSE
RED/PURPLE 1	FUEL SENDING UNIT	TO AMP FUSE
RED/PURPLE 2	2 AMP FUSE	SPLICE
RED/PURPLE 3	LEFT HAND CONTROLS	SPLICE
RED/PURPLE 4	NEG. WIRE HARNESS	SPLICE
RED/PURPLE 5	NEG. WIRE HARNESS	SPLICE
RED/PURPLE 6	LEFT HAND CONTROLS	1.5 AMP FUSE
RED 1	2 AMP FUSE	SPLICE
RED 2	1.5 AMP FUSE	SPLICE
RED 3	STARTER SOLENOID	SPLICE
RED 4	TO AMP FUSE CONTROLS	ENGINE HARNESS
PURPLE/WHITE 1	ESP SWITCH	NEG. WIRE HARNESS
PURPLE/WHITE 2	ESP SWITCH	ENGINE HARNESS
PURPLE/YELLOW 1	SPLICE	PADDLE WHEEL
PURPLE/YELLOW 2	SPLICE	ENGINE HARNESS
PURPLE/YELLOW 3	SPLICE	NEG. WIRE HARNESS
YELLOW/RED 1	LEFT HAND CONTROLS	SPLICE
YELLOW/RED 2	STARTER SOLENOID	SPLICE
YELLOW/RED 3	ENGINE HARNESS	SPLICE

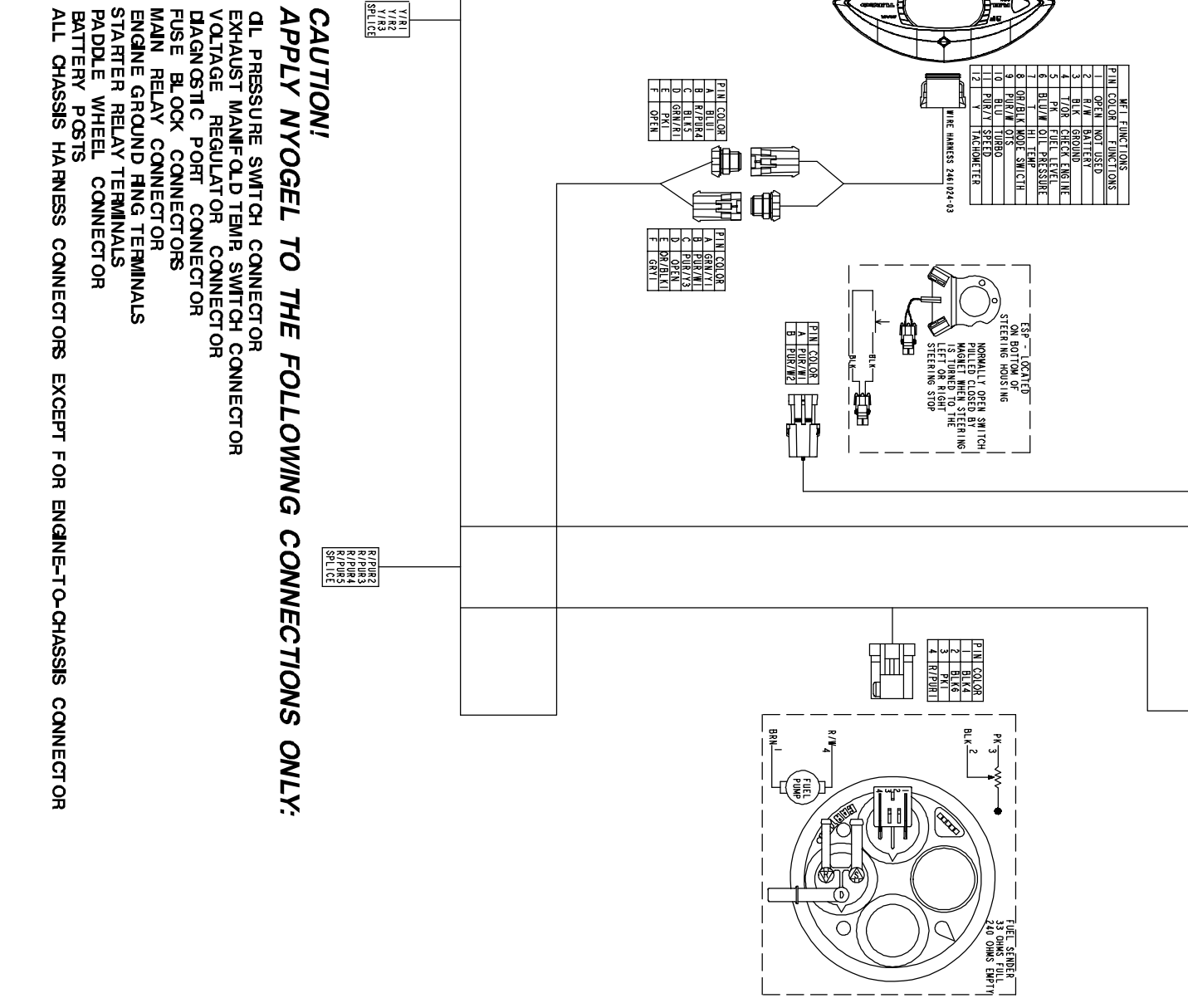
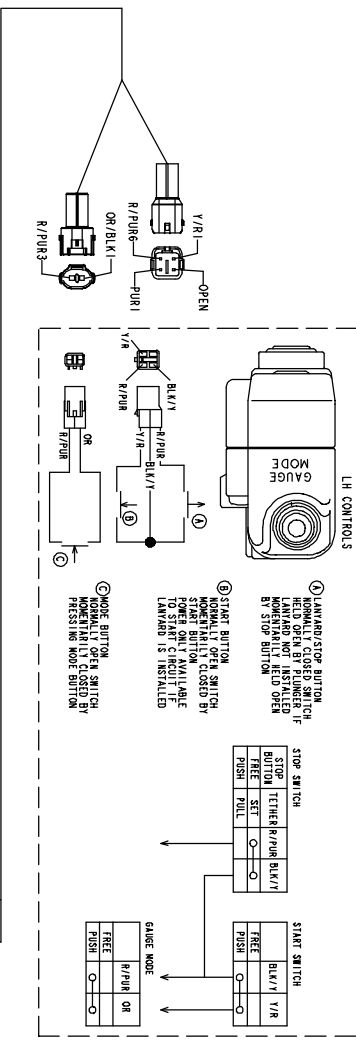
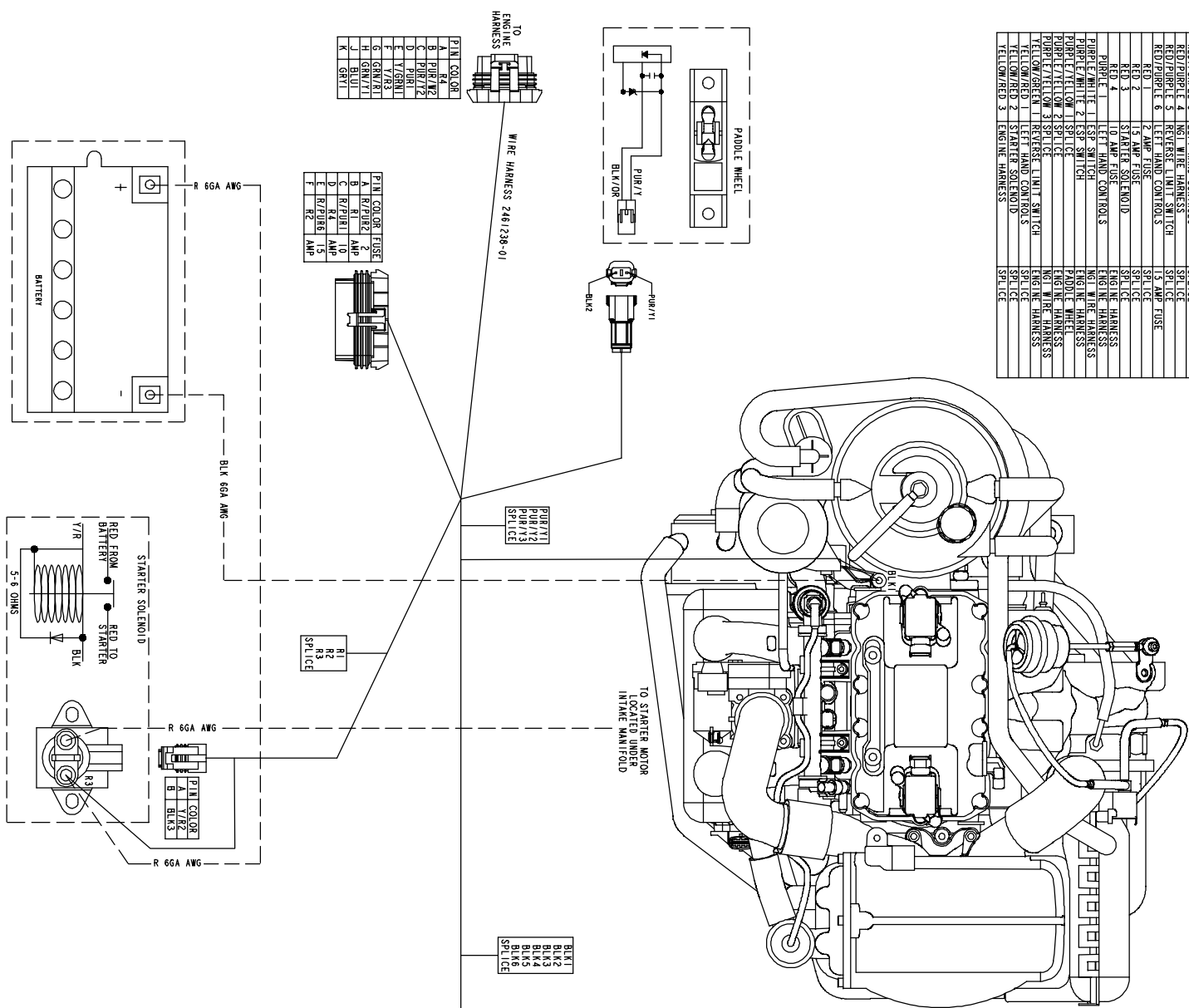

CAUTION!
 APPLY NYOGEL TO THE FOLLOWING CONNECTIONS ONLY:

- DL PRESSURE SWITCH CONNECTOR
- EXHAUST MANIFOLD TEMP SWITCH CONNECTOR
- VOLTAGE REGULATOR CONNECTOR
- DIAGNOSTIC PORT CONNECTOR
- FUSE BLOCK CONNECTOR
- MAIN RELAY CONNECTOR
- ENGINE GROUND RING TERMINALS
- STARTER RELAY TERMINALS
- PADDLE WHEEL CONNECTOR
- BATTERY POSTS

ALL CHASSIS HARNESS CONNECTORS EXCEPT FOR ENGINE-TO-CHASSIS CONNECTOR

MSX 110 / 150 Engine Harness

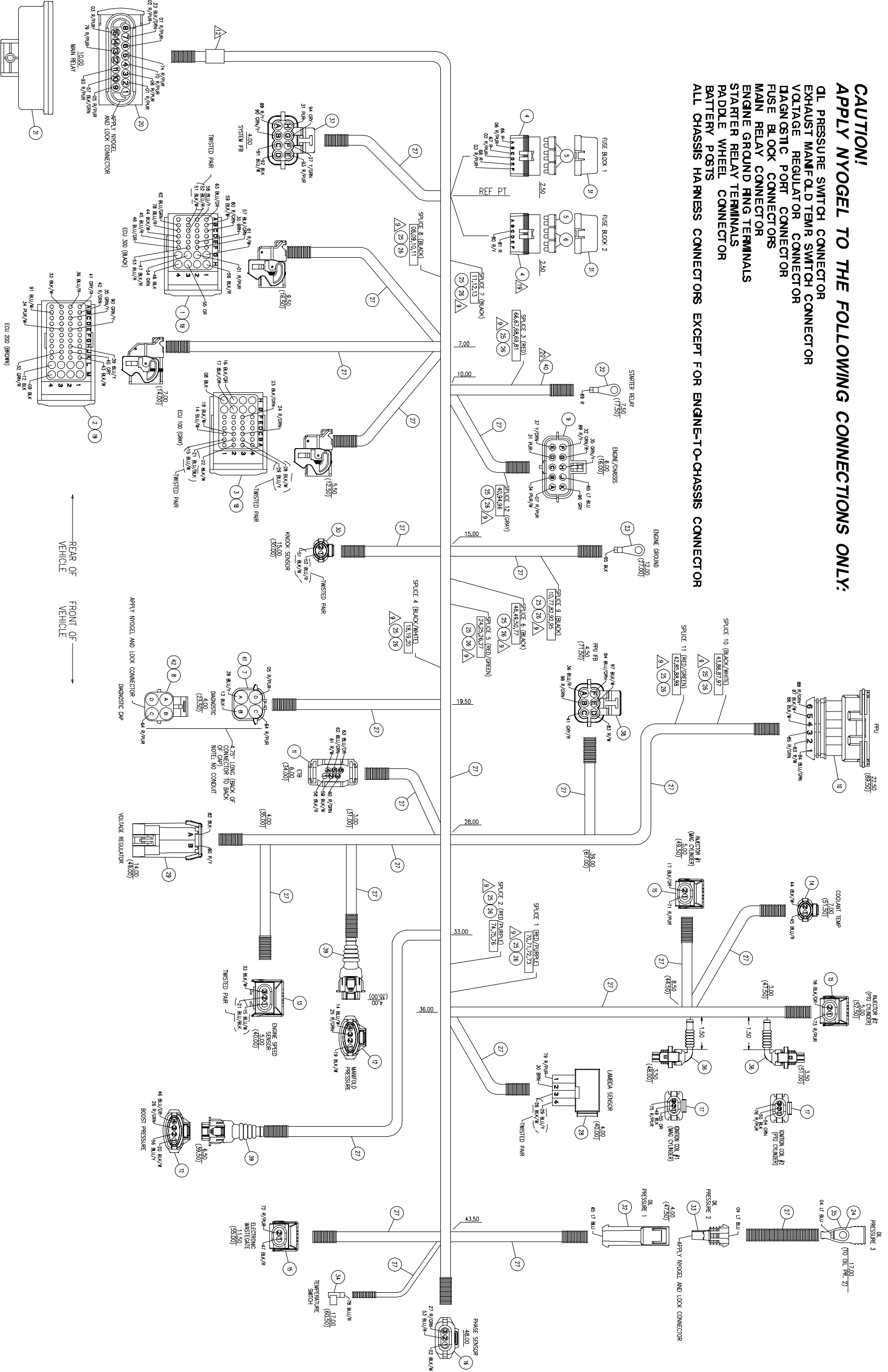

CAUTION!
APPLY NYOGEL TO THE FOLLOWING CONNECTIONS ONLY:

- DL PRESSURE SWITCH CONNECTOR
- EXHAUST MANIFOLD TEMP SWITCH CONNECTOR
- VOLTAGE REGULATOR CONNECTOR
- DIAGNOSTIC PORT CONNECTOR
- FUSE BLOCK CONNECTORS
- MAIN RELAY CONNECTOR
- ENGINE GROUND RING TERMINALS
- STARTER RELAY TERMINALS
- PADDLE WHEEL CONNECTOR
- BATTERY POSTS
- ALL CHASSIS HARNESS CONNECTORS EXCEPT FOR ENGINE-TO-CHASSIS CONNECTOR

MSX 110 / 150 Engine Harness

COLOR CODE	BRN	BROWN
R	RED	RED
GRY	GRAY	GRAY
PUR	PURPLE	PURPLE
GRN	GREEN	GREEN
W	WHITE	WHITE
OR	ORANGE	ORANGE
Y	YELLOW	YELLOW
BLK	BLACK	BLACK
BLU	BLUE	BLUE

WIRE TERMINATION TABLE									
OCT #	COLOR	GAUGE	FROM CONNECTOR	Cavity	TO CONNECTOR	Cavity	FUNCTION		
01	RED/PURPLE	18	MAIN RELAY	2	ECU 300 (232)	C2			
02	RED/PURPLE	16	MAIN RELAY	8	FUSE BLOCK 1	D			
03	RED/PURPLE	16	MAIN RELAY	15	FUSE BLOCK 1	F			
04	LT BLUE	18	OIL PRESSURE 2	A	OIL PRESSURE 3	-			
05	RED/PURPLE	18	DIAGNOSTIC	D	MAIN RELAY	9			
06	RED/PURPLE	16	ENGINE/CHASSIS	3	FUSE BLOCK 1	B			
07	RED/PURPLE	16	ENGINE/CHASSIS	A	MAIN RELAY	6			
08	BLACK	18	SPICE 8	-	ECU 100 (101)	H1			
09	BLACK	18	SPICE 8	-	ECU 200 (212)	M4			
10	BLACK	18	SPICE 9	-	SPICE 9	-			
11	BLACK	18	SPICE 7	-	SPICE 8	-			
12	BLACK	18	SPICE 7	-	ECU 200 (211)	L4			
13	BLACK	18	DIAGNOSTIC	B	SPICE 7	-			
14	BLUE/WHITE	20	MANFOLD PRESSURE	4	ECU 100 (106)	C1			
15	BLUE/WHITE	20 TP	ENGINE SPEED SENSOR	1	ECU 100 (107)	B1			
16	BLACK/ORANGE	18	INJECTOR #2 (PTO)	2	ECU 100 (109)	H2			
17	BLACK/ORANGE	18	INJECTOR #1 (MAG)	2	ECU 100 (110)	C2			
18	BLACK/WHITE	20	SPICE 4	-	ECU 100 (114)	C2			
19	BLACK/WHITE	18	MANFOLD PRESSURE	1	SPICE 4	-			
20	BLACK/WHITE	18	BOOST PRESSURE	1	SPICE 4	-			
21	BLUE/BLACK	20 TP	ENGINE SPEED SENSOR	2	ECU 100 (115)	B2			
22	BLACK/WHITE	20	PHASE SENSOR	7	ECU 100 (116)	M2			
23	BLACK/GREEN	20	MAIN RELAY	1	ECU 100 (119)	F3			
24	RED/GREEN	20	SPICE 5	-	ECU 100 (122)	C3			
25	RED/GREEN	18	MANFOLD PRESSURE	3	SPICE 5	-			
26	RED/GREEN	18	BOOST PRESSURE	3	SPICE 5	-			
27	RED/GREEN	18	PHASE SENSOR	3	SPICE 5	-			
28	BLACK/WHITE	20 TP	LAMBDA SENSOR	3	ECU 100 (123)	B3			
29	BLUE/YELLOW	20 TP	LAMBDA SENSOR	4	ECU 100 (124)	A3			
30	BROWN	20	LAMBDA SENSOR	2	ECU 300 (321)	E2			
31	PURPLE	20	ENGINE/CHASSIS	D	SYSTEM FB	H			
32	GREEN/RED	20	ENGINE/CHASSIS	G	ECU 200 (221)	J3			
33	BLACK/WHITE	20	ENGINE SPEED SENSOR	3	ECU 200 (213)	A3			
34	PURPLE/WHITE	20	ENGINE/CHASSIS	B	ECU 200 (217)	E3			
35	GREEN/YELLOW	20	ENGINE/CHASSIS	H	ECU 200 (227)	C2			
36	BLUE/RED	20	PPU FB	A	ECU 200 (225)	M2			
37	YELLOW/GREEN	20	ENGINE/CHASSIS	E	SYSTEM FB	F			
38	-	-	-	-	-	-			
39	BLUE/YELLOW	20	DIAGNOSTIC	A	ECU 200 (232)	H2			
40	GRAY	20	SPICE 12	-	ECU 200 (233)	J2			
41	GRAY/RED	20	PPU FB	-	ECU 200 (237)	A1			
42	RED/GREEN	20	SPICE 11	-	ECU 200 (238)	B1			
43	BLACK/WHITE	20	SPICE 10	-	ECU 200 (246)	K1			
44	BLACK/WHITE	20	COOLANT TEMP	2	ECU 300 (304)	D4			
45	BLUE/RED	20	COOLANT TEMP	1	ECU 300 (305)	F4			
46	BLUE/ORANGE	20	BOOST PRESSURE	4	ECU 300 (306)	F4			
47	BLACK/RED	18	ELECTRONIC WASTEGATE	1	ECU 300 (307)	G4			
48	BLACK	18	SPICE 6	-	ECU 300 (308)	H4			
49	BLACK	18	IGNITION COIL #1 (MAG)	2	SPICE 6	-			
50	BLACK	18	IGNITION COIL #2 (PTO)	2	SPICE 6	-			
51	BLACK/WHITE	20 TP	KNOCK SENSOR	2	ECU 300 (310)	B3			
52	BLUE/RED	20 TP	KNOCK SENSOR	1	ECU 300 (311)	C3			
53	BLUE/RED	20	PHASE SENSOR	2	ECU 300 (314)	F3			
54	GREEN	16	IGNITION COIL #2 (PTO)	1	ECU 300 (315)	G3			
55	ORANGE	16	IGNITION COIL #1 (MAG)	1	ECU 300 (316)	H3			
56	BLUE/YELLOW	20	BOOST PRESSURE	2	ECU 300 (317)	M2			
57	BLACK/GREEN	20	MAIN RELAY	10	ECU 300 (322)	F2			
58	BLACK/GREEN	18	ETB	1	ECU 300 (332)	H1			
59	BLACK/WHITE	20	ETB	2	ECU 300 (326)	B1			
60	RED/GREEN	20	ETB	3	ECU 300 (327)	C1			
61	RED/WHITE	18	ETB	4	ECU 300 (331)	G1			
62	BLUE/GREEN	20	ETB	5	ECU 300 (302)	B4			
63	BLUE/ORANGE	20	ETB	6	ECU 300 (325)	A1			
64	RED/PURPLE	18	DIAGNOSTIC	C	DIAGNOSTIC CAP	C			
65	LT BLUE	18	ENGINE/CHASSIS	J	OIL PRESSURE 1	A			
66	RED	16	FUSE BLOCK 1	A	SPICE 3	-			
67	RED	16	FUSE BLOCK 1	C	SPICE 3	-			
68	RED	16	FUSE BLOCK 1	E	SPICE 3	-			
69	RED	10	SPICE 3	-	STARTER RELAY	-			
70	RED/PURPLE	16	MAIN RELAY	4	SPICE 1	-			
71	RED/PURPLE	18	SPICE 1	-	INJECTOR #1 (MAG)	1			
72	RED/PURPLE	18	SPICE 1	-	ELECTRONIC WASTEGATE	2			
73	RED/PURPLE	18	SPICE 1	-	INJECTOR #2 (PTO)	1			
74	RED/PURPLE	12	MAIN RELAY	5	SPICE 2	-			
75	RED/PURPLE	16	SPICE 2	-	IGNITION COIL #1 (MAG)	3			
76	RED/PURPLE	16	SPICE 2	-	IGNITION COIL #2 (PTO)	3			
77	BLACK	18	SPICE 9	-	SPICE 6	-			
78	BLUE/RED	20	TEMPERATURE SWITCH	-	ECU 300 (303)	C4			
79	RED/PURPLE	18	MAIN RELAY	13	LAMBDA SENSOR	1			
80	RED/YELLOW	12	VOLTAGE REGULATOR	B	FUSE BLOCK 2	C			
81	RED	12	FUSE BLOCK 2	D	SPICE 3	-			
82	BLACK	12	VOLTAGE REGULATOR	A	SPICE 9	-			
83	RED/WHITE	18	PPU	1	PPU FB	D			
84	BLUE/GREEN	18	PPU	2	PPU FB	F			
85	RED/GREEN	18	PPU	3	SPICE 11	-			

WIRE TERMINATION TABLE									
OCT #	COLOR	GAUGE	FROM CONNECTOR	Cavity	TO CONNECTOR	Cavity	FUNCTION		
86	BLACK/WHITE	18	PPU	4	SPICE 10	-			
87	BLACK/WHITE	18	PPU	5	SPICE 10	-			
88	RED/GREEN	18	PPU	6	SPICE 11	-			
89	RED/YELLOW	18	ENGINE/CHASSIS	F	SYSTEM FB	A			
90	GREEN/YELLOW	20	SYSTEM FB	B	ECU 200 (229)	E2			
91	BLUE/WHITE	20	SYSTEM FB	C	ECU 200 (202)	B4			
92	BLACK	18	SYSTEM FB	D	SPICE 9	-			
93	RED/PURPLE	18	MAIN RELAY	11	SYSTEM FB	E			
94	GRAY	20	SYSTEM FB	G	SPICE 12	-			
95	BLACK	10	ENGINE GROUND	-	SPICE 9	-			
96	GRAY	20	ENGINE/CHASSIS	K	SPICE 12	-			
97	BLACK/WHITE	18	PPU FB	E	SPICE 10	-			
98	RED/GREEN	18	PPU FB	B	SPICE 11	-			

CAUTION!
APPLY NYOGEL TO THE FOLLOWING CONNECTIONS ONLY:
 OIL PRESSURE SWITCH CONNECTOR
 EXHAUST MANIFOLD TEMP SWITCH CONNECTOR
 VOLTAGE REGULATOR CONNECTOR
 DIAGNOSTIC PORT CONNECTOR
 FUSE BLOCK CONNECTORS
 MAIN RELAY CONNECTOR
 ENGINE GROUND RING TERMINALS
 STARTER RELAY TERMINALS
 PADDLE WHEEL CONNECTOR
 BATTERY POSTS
 ALL CHASSIS HARNESS CONNECTORS EXCEPT FOR ENGINE-T-O-CHASSIS CONNECTOR

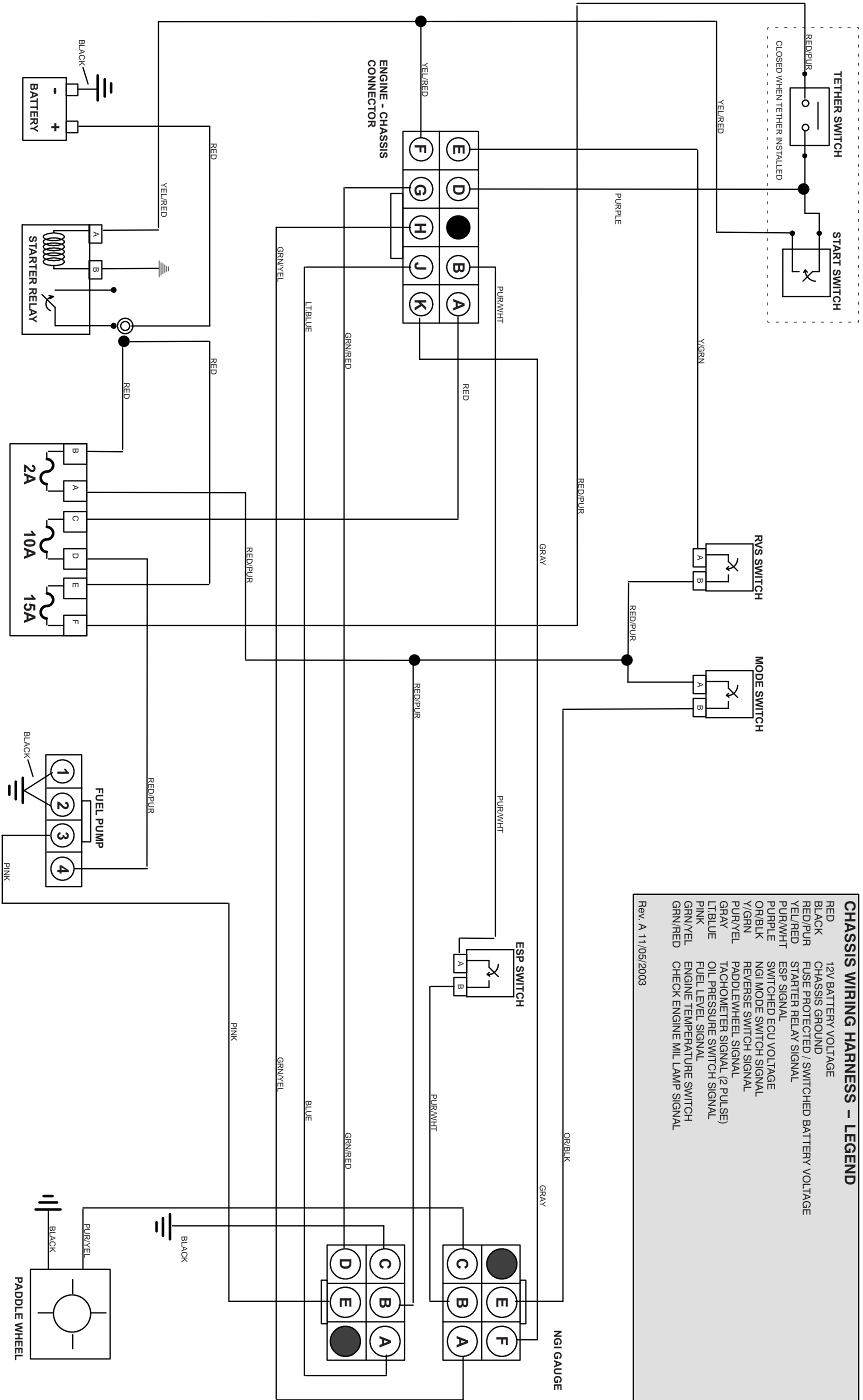

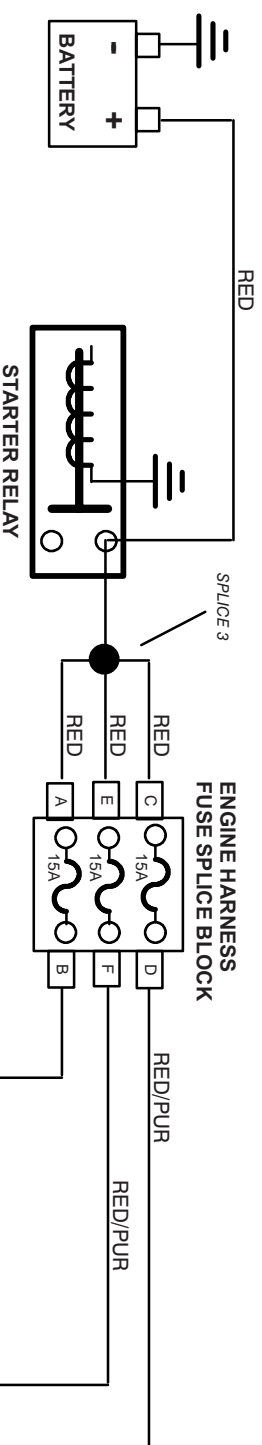

MAIN RELAY CIRCUITS - LEGEND

RED	12V BATTERY VOLTAGE
BLACK	GROUND
RED/PUR	FUSE PROTECTED / RELAY SWITCHED BATTERY VOLTAGE
PURPLE	SWITCHED ECU VOLTAGE FROM TETHER SWITCH
BLK/GRN	SWITCHED ECU VOLTAGE CONTROL
LT.BLUE	OIL PRESSURE SWITCH SIGNAL
GRN/RED	CHECK ENGINE MIL SIGNAL
PUR/WHT	ESP SIGNAL
GRN/YEL	ENGINE TEMP MIL SIGNAL / EXHAUST PIPE WATER TEMP MIL SIGNAL
GREY	TACHOMETER SIGNAL

Rev. B 1/12/2004

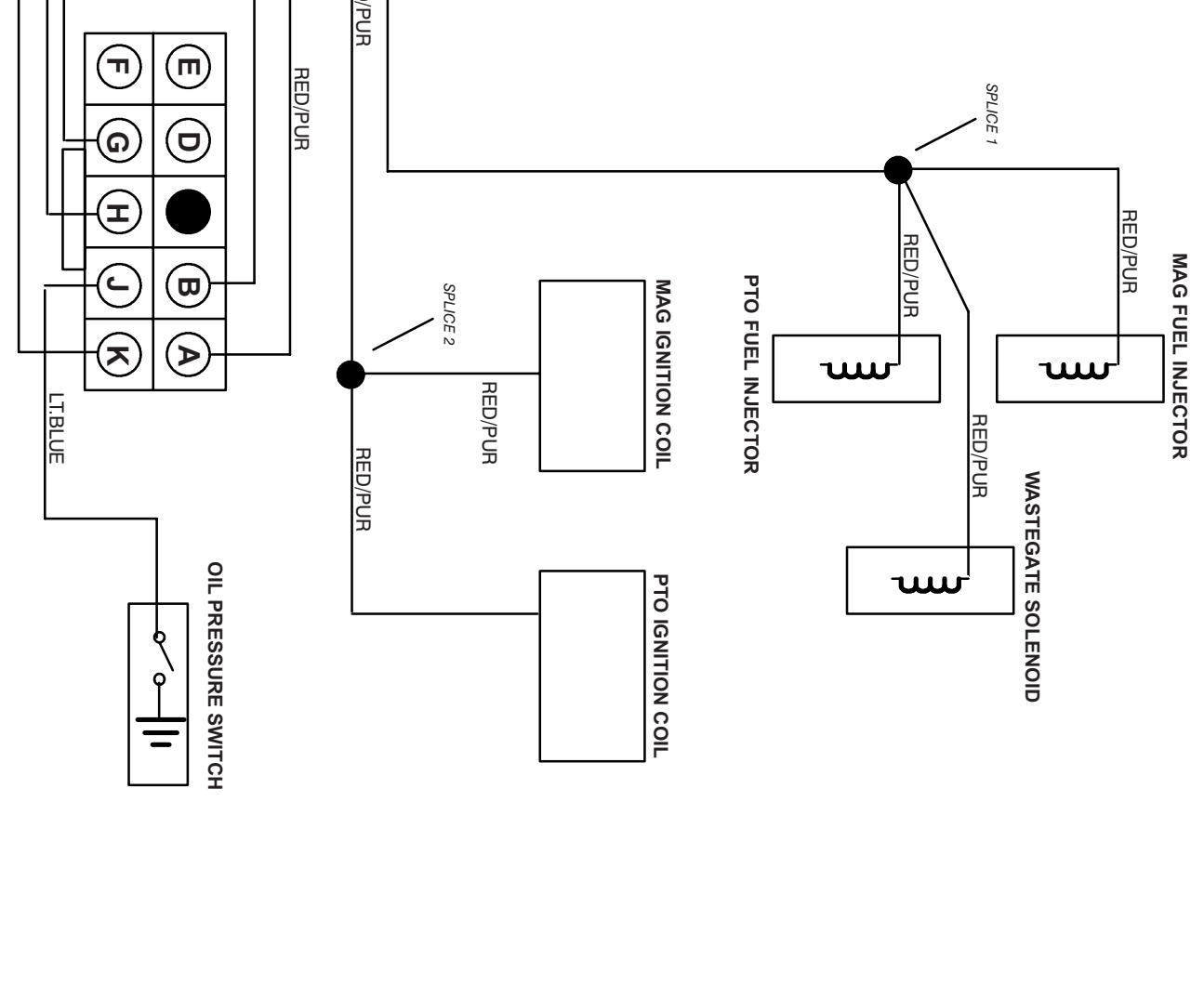
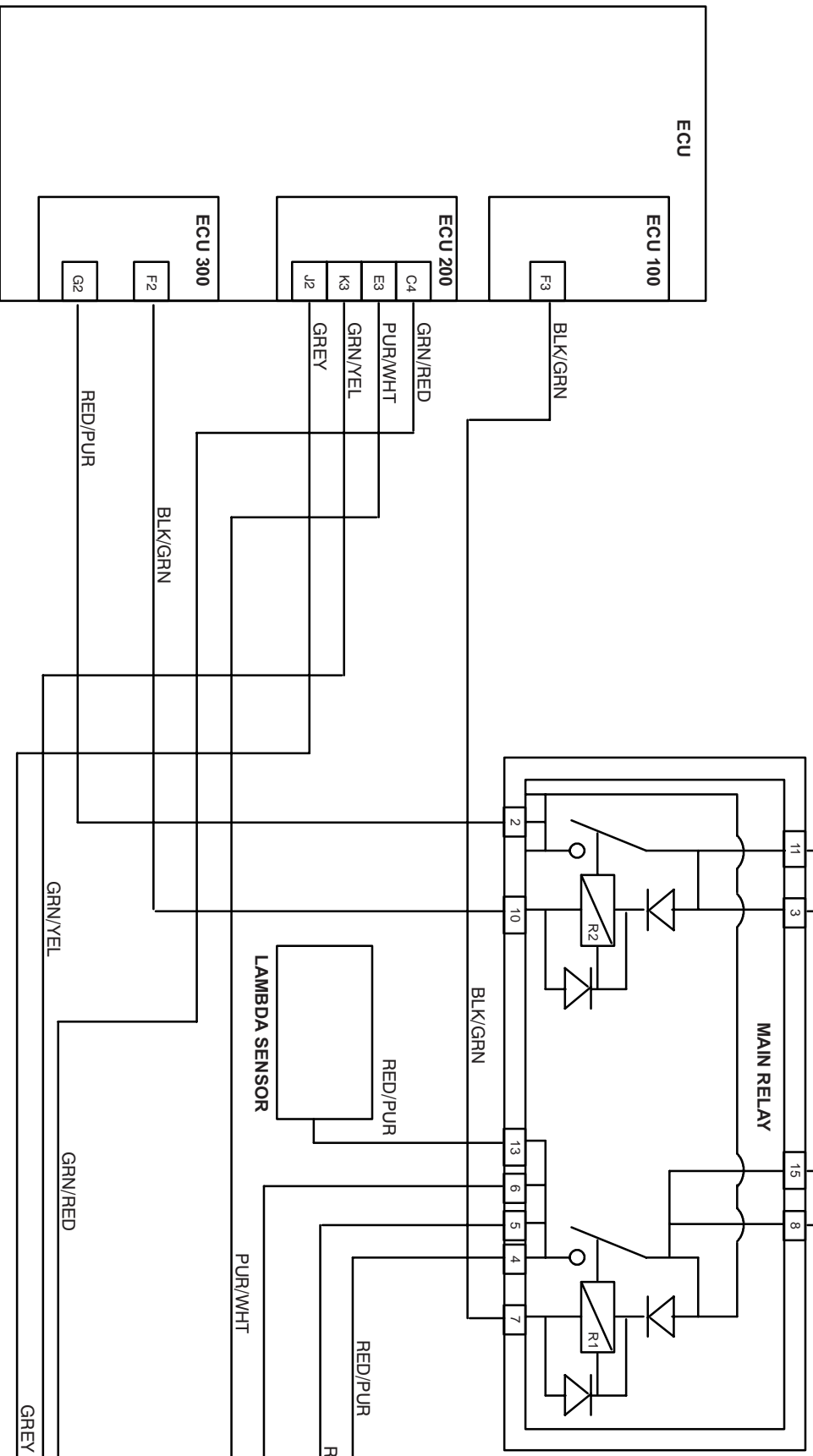
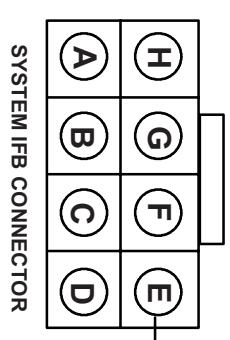

ENGINE/CHASSIS HARNESS CONNECTOR

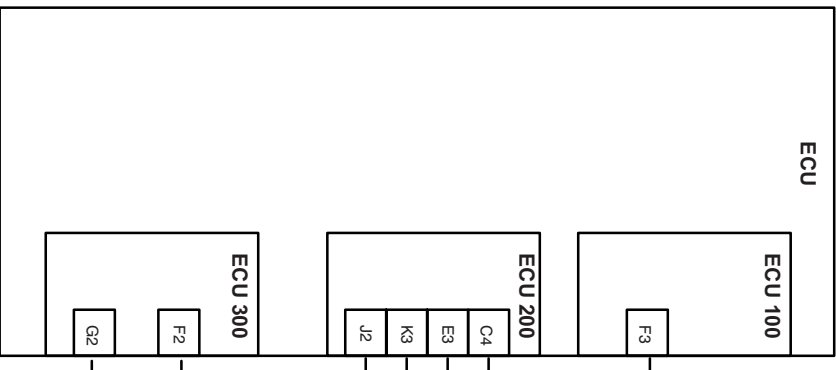

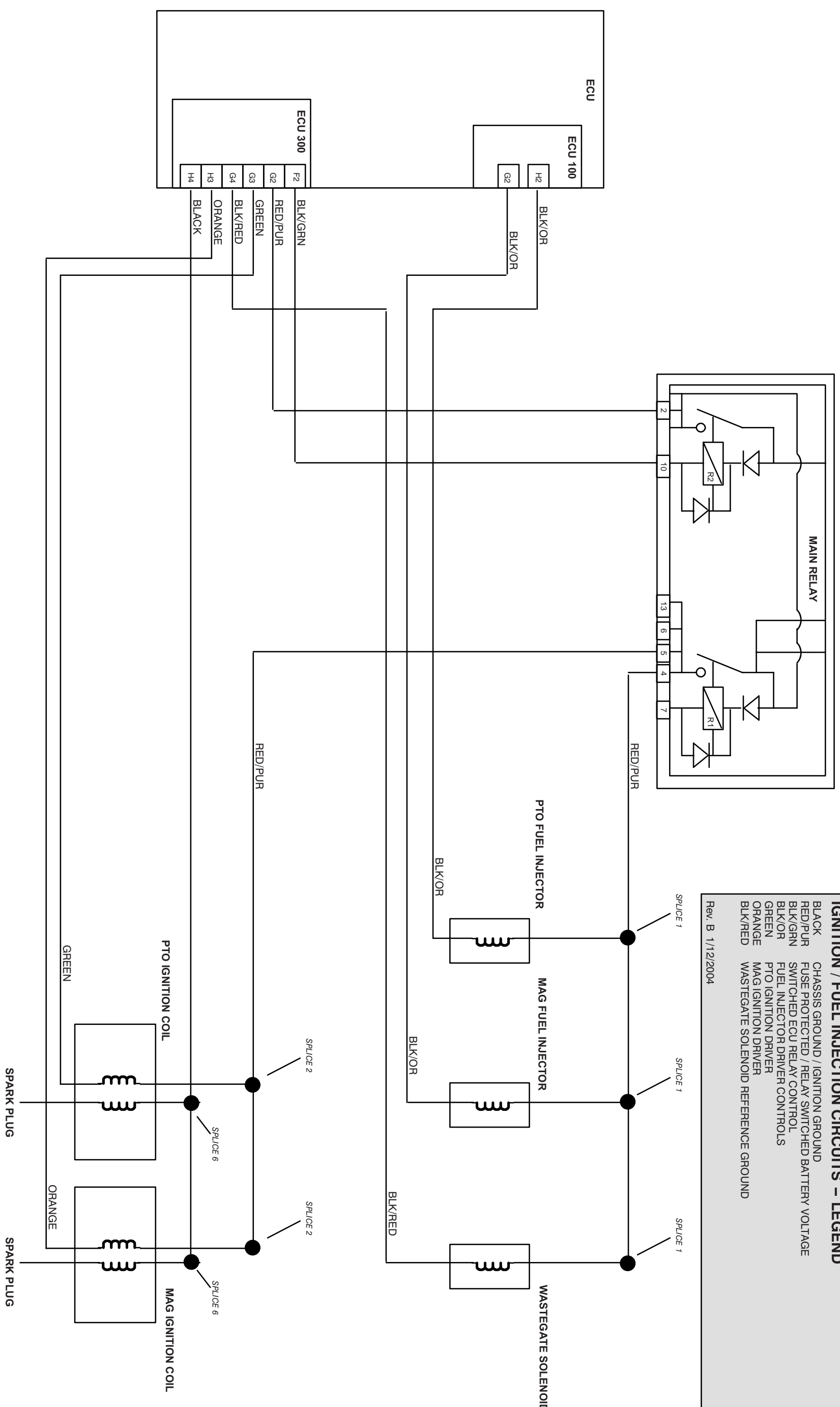

IGNITION / FUEL INJECTION CIRCUITS - LEGEND

- BLACK CHASSIS GROUND / IGNITION GROUND
- RED/PUR FUSE PROTECTED / RELAY SWITCHED BATTERY VOLTAGE
- BLK/PUR SWITCHED ECU RELAY CONTROL
- BLK/GRN FUEL INJECTOR DRIVER CONTROLS
- GREEN PTO IGNITION DRIVER
- ORANGE MAG IGNITION DRIVER
- BLK/RED WASTEGATE SOLENOID REFERENCE GROUND

Rev. B 1/12/2004

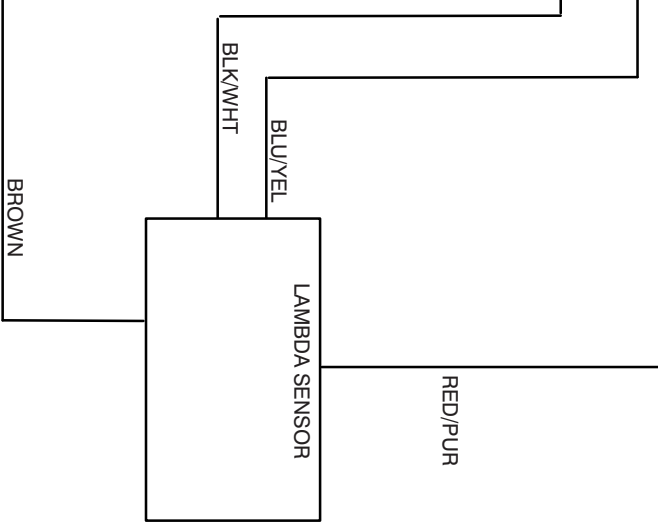
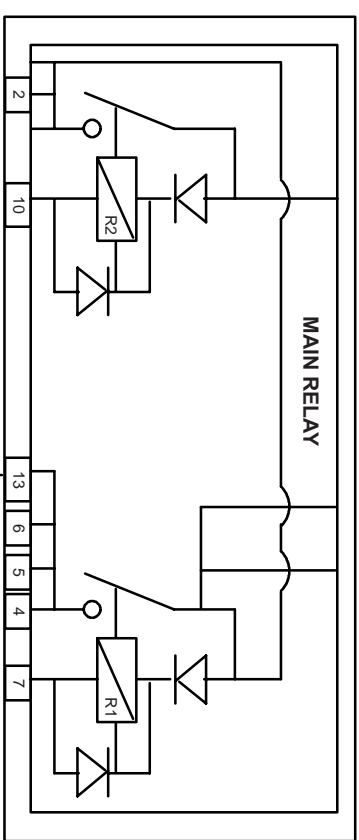
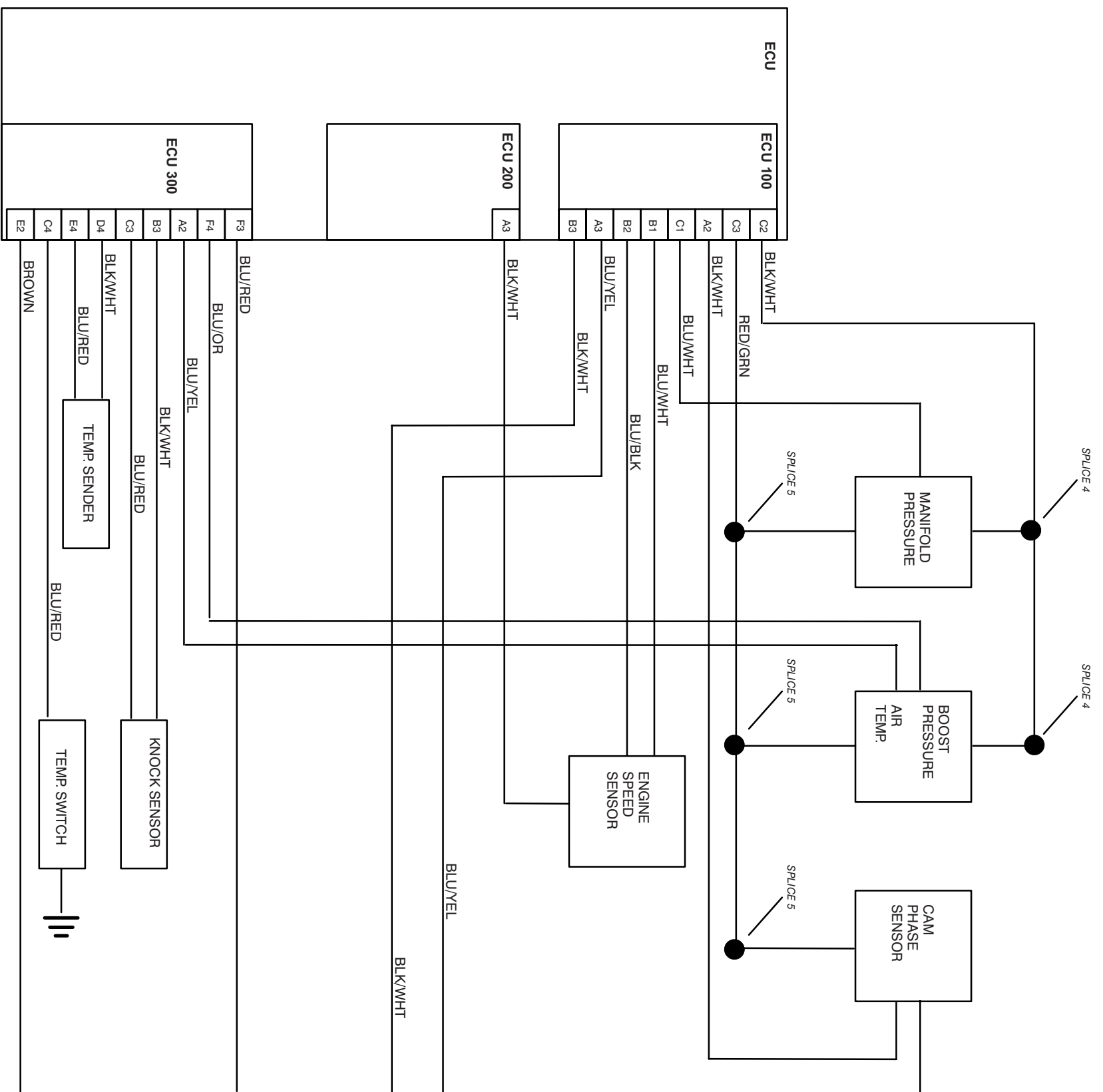

ENGINE MANAGEMENT SENSOR CIRCUITS -- LEGEND

- BLACK CHASSIS GROUND
- RED/PUR FUSE PROTECTED / RELAY SWITCHED BATTERY VOLTAGE
- BLK/WHT SENSOR REFERENCE GROUND
- RED/GRN 5V SENSOR REFERENCE SIGNAL
- BLU/WHT SENSOR RETURN SIGNAL (MANIFOLD PRESSURE SENSOR, SPEED SENSOR,)
- BLU/BLK ENGINE SPEED SIGNAL
- BLU/YEL LAMBDA SENSOR RETURN SIGNAL / INTAKE AIR TEMP SIGNAL
- BLU/RED SENSOR RETURN SIGNAL (PHASE SENSOR, KNOCK SENSOR, TEMP:SENDER, TEMP: SW.)
- BLU/OR BOOST PRESSURE SIGNAL
- BROWN LAMBDA SUPPLY VOLTAGE

Rev. A 11/05/2003

PEDAL POSITION UNIT / ELECTRONIC THROTTLEBODY LEGEND

BLK/WHT REFERENCE GROUND
 RED/GRN 5V SUPPLY VOLTAGE
 BLU/RED P.P.U. POSITION 2 RETURN SIGNAL
 GRY/RED P.P.U. POSITION 1 RETURN SIGNAL
 BLU/GRN P.P.U. POSITION 1 RETURN SIGNAL
 RED/WHT E.T.B. THROTTLE PLATE POSITIVE (+) VOLTAGE
 BLK/RED E.T.B. THROTTLE PLATE NEGATIVE (-) VOLTAGE

Rev. A 11/05/2003

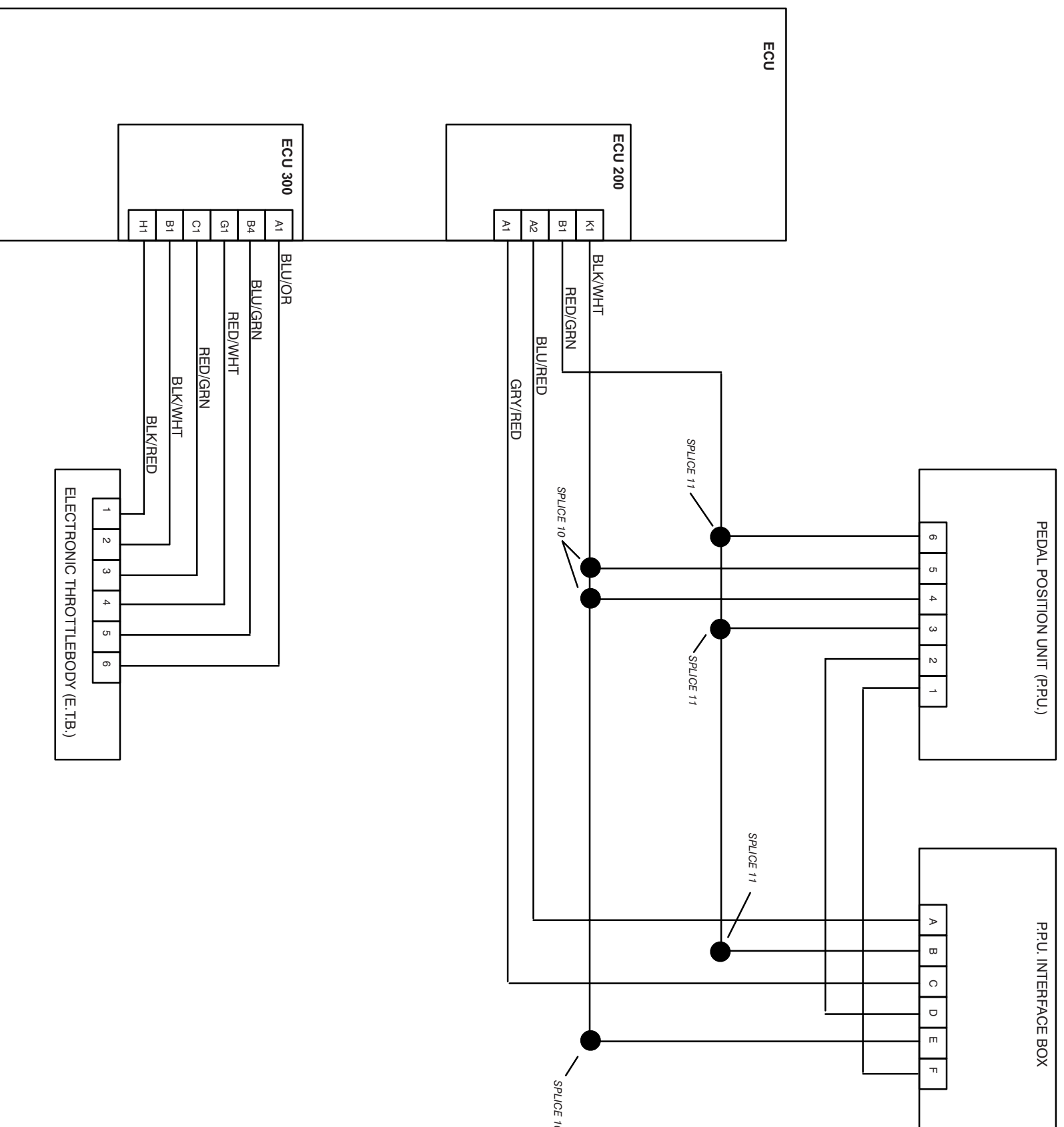

A

Adaptation, [5](#), [28](#)
Armature Testing, [8.16](#)

B

Battery Charging, [2.16](#)
Battery Connections, [2.16](#)
Battery Installation, [2.17](#)
Battery Maintenance
 Off Season Storage, [8.7](#)
 Refilling, [8.7](#)
Battery Safety, [2.15](#)
Battery Testing, [8.5–8.6](#)
Bearing Carrier Installation, [6.9](#)
Bearing Carrier Removal, [6.9](#)
Bilge Siphon System, [2.21](#)
Brush Inspection, Starter Motor, Charging Procedure, [8.7](#)
Brush Replacement, Starter Motor, [8.16](#)

C

Cavitation Troubleshooting, [6.3](#)
Charger Air Cooler / Intercooler Overview, [5.34](#)
Cold Start Protection Mode, [5.35](#)
Conversion Chart, [1.12](#)
Cooling System Pressure Test, [2.13](#)

D

Decimal Equivalent Chart, [1.11](#)
Drain Plugs Intercooler / Intake Manifold, [2.25](#)
Driveshaft / Bearing Carrier Exploded View, [6.6](#)
Driveshaft Inspection, [6.11](#)
Driveshaft Shim Procedure, [6.10](#)

E

ESP Switch Assembly, [7.11](#)

ECU Harness Connectors, [5.28](#)
ECU Overview, [5.1](#), [5.29](#)
Electrical Specifications
 Battery and Charging System, [8.1](#)
 Chassis, [8.1](#)
Electronic Throttle Body / PPU Overview, [5.29](#)
Engine Compression Test, [2.14](#)
Engine Coolant Change Procedure, [2.12](#)
Engine Coolant Inspection, [2.12](#)
Engine Disassembly, [4.21–4.28](#)
Engine Inspection Procedures, [4.29–4.42](#)
Engine Management Circuit Diagrams
 Boost / Air Temperature, [5.20](#)
 Camshaft Position Sensor, [5.24](#)
 Electronic Throttle Body, [5.15](#)
 Engine Coolant Temperature Sensor, [5.22](#)
 Engine Speed Sensor, [5.23](#)
 Fuel Injectors, [5.17](#)
 Fuel Pump Relay, [5.27](#)
 Ignition Coils, [5.18](#)
 Intake Manifold Pressure, [5.21](#)
 Knock Sensor, [5.25](#)
 O2 Sensor, [5.19](#)
 Pedal Position Unit, [5.16](#)
 Wastegate Solenoid, [5.26](#)
Engine Oil Change Procedure, [2.10–2.11](#)
Engine Oil Level Check, [2.10](#)
Engine Removal and Installation, [3.1–3.10](#)
ESP Function Testing, [2.8](#)
ETB Learning Procedure, [5.29](#)
Exhaust Water Injector Maintenance, [2.19](#)
Exploded View
 Alternator Assembly, [8.8](#)
 Chain Guides / Chain Tensioner, [4.14](#)
 Crankshaft / Counter Balancer, [4.20–4.21](#)
 Dry sump Oil Pump, [4.11](#)
 ECU Mounting, [5.11](#)
 Engine Case / Cylinder Head, [4.15–4.16](#)
 ETB / Intake Manifold, [5.9](#)
 Exhaust System, [5.31](#)
 Flywheel / PTO Stub Shaft, [4.19](#)
 Fuel Delivery System, [5.7](#)
 Fuel Rail / Injectors, [5.8](#)
 Fuel Tank, [5.6](#)
 High Pressure Oil Pump, [4.13](#)
 Ignition Coils, [5.10](#)
 Intake / Exhaust Valves, [4.18](#)
 Oil Filter, [4.8](#)
 Piston, [4.17](#)

Starter Motor, [8.13](#)
Thermostat Housing Water Manifold, [4.12](#)
Valve Cover, [4.9](#)
Valve Train, [4.10](#)

F

Fastener Guide
Final Drive / Propulsion, [6.2](#)
Hull and Body, [7.2](#)
Final Drive / Propulsion Quick Reference Guide, [6.1](#)
Flush Kit, [2.3](#)
Footpad Removal / Application, [7.18](#)
Fuel / Water Separator, [2.20](#)
Fuel Filter, [2.20](#)
Fuel Injection / Ignition system Specifications, [5.2](#)
Fuel System Pressure Test, [2.14](#)
Fuses, [2.18](#)

G

Gasoline Safety Guidelines, [2.20](#)
General Lubrication
Reverse System, [2.5](#)
Steering Cable and Steering Joints, [2.5](#)
Steering Nozzle, [2.5](#)

H

Handlebar / Steering Post Removal and Installation, [7.14](#)
Handlebar Maintenance, [2.24](#)
Harness Connectors
ECU C100, [5.12](#)
ECU C200, [5.13](#)
ECU C300, [5.14](#)
Compartment Door Assembly, [7.7](#)
Hull Assembly, MSX, [7.5–7.6](#)
Hull Repair, [7.18](#)
Hull Specifications, [7.1](#)

I

Impeller Clearance, [6.11](#)
Intake Manifold Fastener Re–Torque Procedure, [2.24](#)
Intake Scoop / Ride Plate Removal and Installation, [6.21–6.22](#)

M

Maintenance, Bilge Drain Plug, [2.21](#)
Maintenance Safety Warnings, [2.2](#)
Maintenance Service Products, [2.4](#)
Maintenance Specific Tools, [2.3](#)
MSX 110 Emission Information, [1.6](#)
MSX 110 General Information, [1.6–1.7](#)
MSX 150 Emission Information, [1.8](#)
MSX 150 General Information, [1.8–1.9](#)

N

NGI Gauge, [8.2–8.3](#)

O

Off Season Storage, [2.26](#)

P

Paint Codes, [7.1](#)
Periodic Maintenance Table, [2.1](#)
PPU Assembly, [7.12](#)
Pump / Propulsion Specifications, [6.1](#)
Pump Assembly Exploded View, [6.4](#)
Pump Housing Installation, [6.8](#)
Pump Housing Removal, [6.8](#)
Pump Induction Assembly Exploded View, [6.7](#)
Pump Maintenance, [2.22–2.23](#)
Pump Removal, [6.8](#)
PWC Identification Numbers, [1.3](#)
PWC Publication Part Numbers, [1.4](#)

R

- Replenishing Battery Fluid, [2.16](#)
- Reverse Cable Adjustment, [2.7](#), [7.17](#)
- Reverse System Assembly, [7.13](#)
- Routings
 - Air Inlet Hoses, [5.3](#)
 - Bilge Siphon Hoses, [7.4](#)
 - Fuel Hoses, [5.4](#)
 - Reverse Cable, [7.3](#)
 - Steering Cable, [7.3](#)
 - Vent Hose, [5.5](#)
- RPM Limiting Modes / RPMs, [5.35](#)

S

- Sacrificial Anode, [6.20](#)
- Safety Warning Guidelines, [1.5](#)
- Seat Assembly, [7.9](#)
- Shroud and Storage Assemblies, [7.8](#)
- Spark Plug, [2.18](#)
- Special Service Tools, [1.14–1.15](#)
- Special tools, Engine, [4.7](#)
- Specifications
 - Engine, [4.1–4.2](#)
 - Engine Fasteners, [4.3–4.6](#)
- Standard Torque Specifications, [1.10](#)
- Starter Assembly, [8.17](#)
- Starter Motor Cleaning, [8.16](#)
- Starter Solenoid Bench Test, [8.17](#)
- Starter Motor Disassembly and Assembly, [8.14–8.18](#)
- Stator Assembly, [6.14](#)
- Stator Assembly Exploded View, [6.5](#)
- Stator Disassembly, [6.12–6.14](#)
- Steering Cable Adjustment, [2.7](#), [7.17](#)
- Steering Cable Installation, [7.16](#)
- Steering Cable Removal and Installation, [7.15–7.16](#)
- Steering Control Assembly, [7.10](#)
- Steering Post Removal and Installation, [2.6](#)

- System Interface Box, [8.11](#)
- Diagnostics Mode, [8.11](#)

T

- Tap Drill Sizes, [1.13](#)
- Throttle Cable Adjustment, [2.19](#)
- Trouble Codes
 - Boost / Air Temp. Sensor, [5.20](#)
 - Camshaft Position Sensor, [5.24](#)
 - ECU / Engine Management System, [5.29](#)
 - Engine Coolant Temp. Sensor, [5.22](#)
 - Engine Speed Sensor, [5.23](#)
 - ETB / Electronic Throttle Body, [5.15](#)
 - Fuel Injectors, [5.17](#)
 - Fuel Pump Driver, [5.27](#)
 - Ignition Coils, [5.18](#)
 - Intake Manifold Pressure Sensor, [5.21](#)
 - Knock Sensor, [5.25](#)
 - O2 / Lambda Sensor, [5.19](#)
 - PPU / Pedal Position Unit, [5.16](#)
 - Wastegate Solenoid, [5.26](#)
- Troubleshooting
 - Charge Air Cooler, [5.34](#)
 - Engine Turns Over; Will Not Start, [5.37](#)
 - Engine Will Not Turn Over, [5.36](#)
 - Engine Lacks Performance / RPM Limits, [5.40–5.43](#)
 - Engine Stall; Will Not Re–Start, [5.39](#)
 - Engine Stalls; Will Re–Start, [5.38](#)
 - ETB / PPU, [5.30](#)
- Turbocharger / Wastegate Overview, [5.32–5.33](#)

V

- Valve Clearance Adjustment Procedure, [2.8–2.9](#)
- Ventilation Troubleshooting, [6.3](#)

W

- Wiring Diagram
 - Charging System, [8.9](#)
 - NGI Gauge MIL Indicators, [8.4](#)
 - Start / Stop System, [8.10](#)
 - System Interface Box, [8.12](#)



Part Number 9919062
Printed in U.S.A